

# MANUAL COMPLETO COMPLETE MANUAL



# DEMARTÊZ

mobília

DEMÓBILE Indústria de Móveis Ltda.  
Rua : Jurutau, 1350 - Pq. Industrial II.  
Cep.: 86703-070  
Arapongas - PR - Brasil  
demobile@demobile.com.br

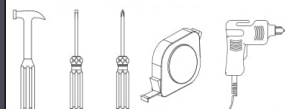

## Avisos

1. Ler atentamente as instruções do manual antes de iniciar a montagem do móvel.
2. A montagem deverá ser feita em superfície limpa e plana, aconselhamos forrar o chão com a embalagem do produto, para não danificar.
3. Os parafusos devem ser apertados periodicamente.
4. Evitar batidas e contato com objetos cortantes.
5. O peso máximo de carga informado refere-se a objetos distribuídos de maneira uniforme sobre toda área de contato da peça.

### Limpeza e Conservação

Efetuar a limpeza somente com pano macio limpo e seco.  
Não Utilizar produtos abrasivos ou químicos.

### Garantia

1. O fabricante responsabiliza-se apenas pelas peças do produto.
2. A montagem incorreta acarretará na perda da garantia e das assistências, desta forma o produto deverá ser montado por profissional qualificado.
3. Não estão cobertos pela garantia problemas que tenham origem na utilização inadequada do produto ou na exposição do mesmo a intempéries como: infiltrações, infestação de pragas em geral, aparecimento de mofo e outros, decorrentes do ambiente de instalação.

Assistência Técnica: Em caso de peças em assistência técnica é necessário que as mesmas sejam solicitadas junto a loja ou site no qual a compra do produto foi realizada

## Warnings

1. Read the manual instructions carefully before starting to assemble the furniture.
2. The assembly must be done in clean and flat surface, we advise to put the product packaging on the floor, not to damage it during the assembling.
3. The screws must be tightened periodically.
4. Avoid hitting and contacting sharp objects.
5. The payload informed refers to the objects distributed all over the piece contact area.

### Cleaning and conservation

Clean the product just with a soft, cleaned and dry cloth.  
Do not use abrasive or chemicals products.

### Warranty

1. The manufacturer is only responsible for product parts.
2. Incorrect assembling will make you lost the guarantee and assistance, in this way the product must be assembled by qualified professional.
3. It is Not covered by the warranty problems caused by an inappropriate use of the product or product exposure even in bad weather, such as: infiltrations, pest infestation in general, appearance of mold and others, caused by the installation environment.

Technical Assistance: Damaged pieces! Ask on the stores you bought it.

## Advertencias

1. Lee atentamente las instrucciones del manual antes de empezar a armar los muebles.
2. El montaje debe hacerse en superficie limpia y plana, utilice el empaque del Producto para cubrir el piso
3. Los tornillos deben ser apretados periódicamente
4. Evite golpear y chocar objetos punzantes
5. El peso máximo de carga tiene relación a los objetos distribuydos sobre toda el área de contacto de la pieza.

### Limpeza y conservación

Limpiar solo con un trapo suave, limpio y seco  
No utilice productos abrasivos o productos químicos

### Garantía

1. El fabricante solo es responsable a las partes del producto.
2. Armar incorrectamente supone la pérdida de garantía y repuestos, de esta manera el producto debe ser ensamblado por profesional calificado
3. No es garantizado problemas derivados del uso inapropiado del producto, o exposición del producto al mal tiempo, como: infiltraciones, infestación de plagas en general, aparición de moho y otros.

Asistencia técnica: en caso de piezas rotas es necesario que sea solicitadas las mismas a la tienda o sitio web donde se compró el producto.

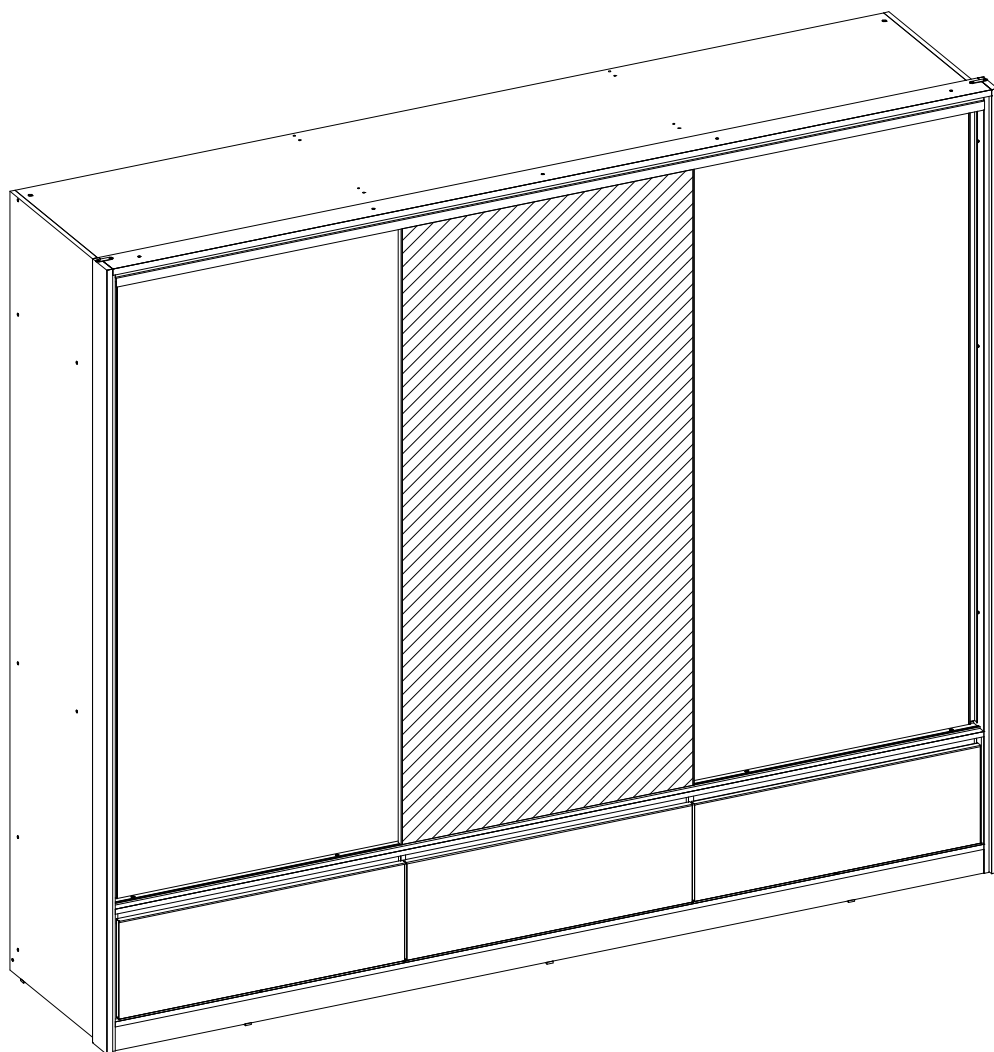

**D37010 GUARDA ROUPA CASAL 03 PORTAS CORRER 07 GAVETAS LOUNGE**

**D37010 WARDROBE 03 DOORS 07 DRAWERS LOUNGE**

**D37010 CLOSET MATRIMONIAL 02 PUERTAS 07 CAJONES LOUNGE**

D37010

GUARDA ROUPA CASAL 03 PORTAS CORRER 07 GAVETAS LOUNGE  
 WARDROBE 03 DOORS 07 DRAWERS LOUNGE  
 CLOSET MATRIMONIAL 02 PUERTAS 07 CAJONES LOUNGE

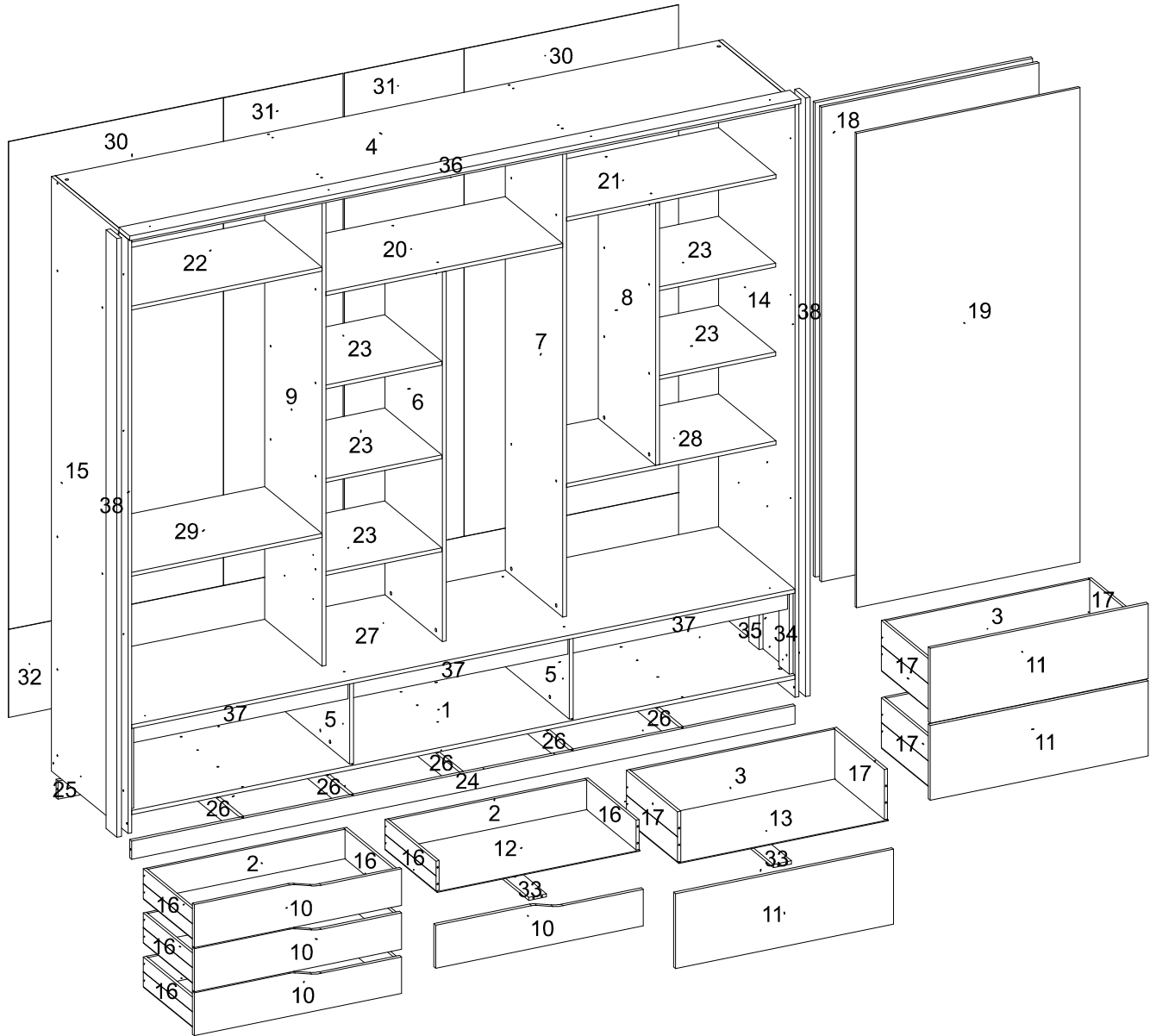

SEQ.	CODIGO	AMENDOLA TOUCH	AVENA GRAFITO	REF_03	REF_04	REF_05	REF_06	REF_07	DESCRICAÇÃO DE PECAS DESCRIPTION OF PARTS DESCRIPCION DE LAS PIEZAS	DESCRIPTION_EN	DESCRIPCION_ES	DIMENSÕES / QUANTIDADE DIMENSIONS / QUANTITY DIMENSIONES / CANTIDAD	QTD
1	03130	138	157	-	-	-	-	-	BASE	BASE	BASE	2598 X 600 X 15	1
2	06113	138	157	-	-	-	-	-	CONTRA FUNDO	DRAWER BACK	CONTRA FONDO	772 X 114 X 12	4
3	06115	138	157	-	-	-	-	-	CONTRA FUNDO MAIOR	DRAWER BACK	CONTRA FONDO	798 X 192 X 12	3
4	07106	138	157	-	-	-	-	-	CHAPEU	TOP PANEL	TAPA SUPERIOR DEL ROPERO	2598 X 600 X 15	1
5	08255	138	157	-	-	-	-	-	DIVISAO GAVETEIRO	TUBE DIVISION	DIVISION GAVETEIRO	584 X 315 X 15	2
6	08256	138	157	-	-	-	-	-	DIVISAO CENTRAL	DIVISION CENTRAL	DIVISION DERECHA	1418 X 450 X 15	1
7	08257	138	157	-	-	-	-	-	DIVISAO DIREITA	DIVISION DERECHA	DIVISION DERECHA	1850 X 450 X 15	1
8	08258	138	157	-	-	-	-	-	DIVISAO DIREITA MENOR	RIGHT DIVISION MINOR	DIVISION DERECHA MENOR	1006 X 450 X 15	1
9	08259	138	157	-	-	-	-	-	DIVISAO ESQUERDA	LEFT DIVISION	DIVISION IZQUIERDA	1850 X 450 X 15	1
10	09153	138	157	-	-	-	-	-	FRENTE DE GAVETA	DRAWER FRONT	FRENTE DEL CAJON	812 X 165 X 15	4
11	09155	134	159	-	-	-	-	-	FRENTE DE GAVETA MAIOR	DRAWER FRONT	FRENTE DEL CAJON	854 X 287 X 15	3
12	10095	138	157	-	-	-	-	-	FUNDO GAVETA	DRAWER BASE	FONDO DEL CAJÓN	794 X 408 X 3	4
13	10097	138	157	-	-	-	-	-	FUNDO GAVETA MAIOR	DRAWER BASE	FONDO DEL CAJON	820 X 408 X 3	3
14	11332	136	158	-	-	-	-	-	LATERAL DIREITA	SIDE PANEL RIGHT	LATERAL DERECHA	2280 X 600 X 15	1
15	11333	136	158	-	-	-	-	-	LATERAL ESQUERDA	SIDE PANEL LEFT	LATERAL IZQUIERDA	2280 X 600 X 15	1
16	12017	138	157	-	-	-	-	-	LATERAL DE GAVETA	DRAWER SIDE	LATERAL DEL CAJON	400 X 114 X 12	8
17	12018	138	157	-	-	-	-	-	LATERAL DE GAVETA MAIOR	DRAWER SIDE	LATERAL DEL CAJON	400 X 192 X 12	6
18	14261	151	163	-	-	-	-	-	PORTA DE CORRER	SLIDING DOOR	PUERTA CORREDIZA	1820 X 852 X 15	2
19	14262	138	157	-	-	-	-	-	PORTA DE CORRER CENTRAL	SLIDING DOOR	PUERTA CORREDIZA	1820 X 875 X 12	1
20	15142	138	157	-	-	-	-	-	PRATELEIRA SUPERIOR CENTRAL	CENTRAL SUPERIOR SHELF	PRATELERA SUPERIOR CENTRAL	928 X 450 X 15	1
21	15143	138	157	-	-	-	-	-	PRATELEIRA SUPERIOR DIREITA	PRATELERA SUPERIOR DERECHA	TOP RIGHT SHELF	820 X 450 X 15	1
22	15144	138	157	-	-	-	-	-	PRATELEIRA SUPERIOR ESQUERDA	PRATELERA SUPERIOR IZQUIERDA	LEFT UPPER SHELF	820 X 450 X 15	1
23	15145	138	157	-	-	-	-	-	PRATELEIRA	SHELF	ESTANTERIA	456 X 448 X 15	5
24	16314	134	159	-	-	-	-	-	RODAPE FRONTAL	BOTTOM BOARD FRONT	ZÓCALO FRONTAL	2598 X 70 X 15	1
25	16315	20	20	-	-	-	-	-	RODAPE TRASEIRO	BOTTOM BOARD BACK	ZÓCALO TRASERO	2598 X 70 X 15	1
26	16316	20	20	-	-	-	-	-	RODAPE INTERNO	BOTTOM BOARD INTERNAL	ZÓCALO INTERNO	561 X 70 X 15	5
27	19202	138	157	-	-	-	-	-	TAMPO GAVETEIRO MAIOR	MAJOR TANK CAP	TAPA CAJERA MAYOR	2598 X 600 X 15	1
28	19203	138	157	-	-	-	-	-	TAMPO GAVETEIRO DIREITO	RIGHT TAPSET COVER	TAMPO GOLETE DERECHO	820 X 450 X 15	1
29	19204	138	157	-	-	-	-	-	TAMPO GAVETEIRO ESQUERDO	LEFT TANK CAP	TAPA CAJERA IZQUIERDA	820 X 450 X 15	1
30	20347	138	157	-	-	-	-	-	TRASEIRO LATERAL	REAR SIDE	TRASERO LATERAL	1870 X 840 X 3	2
31	20348	138	157	-	-	-	-	-	TRASEIRO CENTRAL	CENTRAL REAR	TRASERO CENTRAL	1870 X 468 X 3	2
32	20349	20	20	-	-	-	-	-	TRASEIRO DO GAVETEIRO	REAR DOOR	TRASERO DEL CAJERO	2624 X 337 X 3	1
33	28069	20	20	-	-	-	-	-	APOIO DE GAVETA	DRAWER SUPPORT	APOYO DE GAVETA	400 X 70 X 12	7
34	28071	138	157	-	-	-	-	-	DISTANCIADOR FRONTAL INFERIOR	FRONT DISTANCER	DISTANCIADOR FRONTAL	315 X 80 X 15	2
35	28072	20	20	-	-	-	-	-	DISTANCIADOR TRASEIRO INFERIOR	REAR DISTANCER	DISTANCIADOR TRASERO	315 X 80 X 15	2
36	29073	134	159	-	-	-	-	-	VISTA SUPERIOR	UPPER VIEW	VISTA SUPERIOR	2628 X 85 X 18	1
37	29084	134	159	-	-	-	-	-	VISTA DA GAVETA	VIEW OF THE DRAWER	VISTA DEL GAVETA	846 X 70 X 15	3
38	29075	134	159	-	-	-	-	-	VISTA LATERAL	SIDE FRAME	VISION LATERAL	2296 X 85 X 18	2

# LISTA DE ACESSÓRIOS / LIST OF ACCESSORIES / LISTA DE ACCESORIOS

SEQ.	CODIGO.	DESCRIÇÃO	DESCRIPTION_EN	DESCRIPCION_ES	QTD.
-	01219	KIT DE ACESSÓRIOS	KIT OF ACCESSORIES	KIT DE ACCESORIOS	1
A	9905002	PARAFUSO 3.5 X 12 MM CHATA PHILIPS	PHILIPS FLAT HEAD SCREW	TORNILLO CHATA PHILIPS	192
B	9905003	PARAFUSO 3.5 X 12 MM FLANGEADO PHILIPS	PHILIPS FLANGE SCREW	TORNILLO DE BRIDA PHILIPS	5
BC	9920069	SISTEMA PORTA CORRER KIT 03 PORTAS FOLGA ZERO GUIA VERMELHO 99206 COM ROLAMENTO	SLIDING DOOR SYSTEM	SISTEMA DE PUERTAS CORREDERAS	1
C	9905004	PARAFUSO 3.5 X 16 MM CHATA PHILIPS	PHILIPS FLAT HEAD SCREW	TORNILLO CHATA PHILIPS	70
CA	9919044	TRILHO DUPLO INFERIOR 2597 MM LAR 47 ALUMINIO COD 1055 BRONZE	LOWER DOUBLE RAIL	RIEL DOBLE INFERIOR	1
CB	9919045	TRILHO SUPERIOR E 2597 MM ALUMINIO COD 1031 BRONZE LARG 67 - MM	TOP RAIL E	RIEL SUPERIOR	1
D	9905018	PARAFUSO 3.5 X 25 MM CHATA PHILIPS	PHILIPS FLAT HEAD SCREW	TORNILLO CHATA PHILIPS	8
DB	9901072	CABIDEIRO OBLONGO 340 X 25 X 15 MM ALUMINIO	HANGER	PERCHERO	1
DB	9901073	CABIDEIRO OBLONGO 448 X 25 X 15 MM ALUMINIO	HANGER	PERCHERO	1
DB	9901074	CABIDEIRO OBLONGO 812 X 25 X 15 MM ALUMINIO	HANGER	PERCHERO	1
E	9905020	PARAFUSO 3.5 X 30 MM CHATA PHILIPS	PHILIPS FLAT HEAD SCREW	TORNILLO CHATA PHILIPS	46
EA	9902059	MOLDURA DE ALUMINIO 1818 X 15 MM CHAPA15 MM COD 1557 ABA FRONTAL 4 MM BRONZE	ALUMINUM FRAME	MARCO DE ALUMINIO	4
EA	9902060	MOLDURA DE ALUMINIO 856 X 15 MM CHAPA15 MM COD 1557 ABA FRONTAL 4 MM BRONZE	ALUMINUM FRAME	MARCO DE ALUMINIO	3
FC	9902061	PERFIL PUXADOR ALUMINIO 1818 MM COD 1110 2 MM BRONZE	HANDLE	TIRADOR	2
H	9905015	PARAFUSO 4.5 X 45 MM CHATA PHILIPS	PHILIPS FLAT HEAD SCREW	TORNILLO CHATA PHILIPS	81
IA	9928010	PERFIL H 1850 X 16 X 6 MM PLASTICO	PLASTIC H STRIP	TIRA PLASTICA H	1
IC	9912005	ETIQUETA LOGO DEMARTEZ	TAG	ETIQUETA	1
J	9920029	PINO MINIFIX 12 MM	MINIFIX PIN	PINO MINIFIX	14
K	9920009	CASTANHA MINIFIX 12 MM	MINIFIX CHESTNUT	LOS SIMPSON	14
L	9920011	CAVILHAS 6 X 30 MM	WOODEN PEG	CLAVIJA DE MADERA	116
M	9920012	CAVILHAS 6 X 50 MM	WOODEN PEG	CLAVIJA DE MADERA	8
MA	9920053	JUNCAO METALICA 50 X 13 MM	METAL JUNCTION	JUNCIÓN METALICA	2
O	9913013	CORREDICA TELESCOPICA LARG 32 MM DE 350 MM METAL FGVTN	TELESCOPIC SLIDE	RIEL TELESCOPICA	7
OA	9912006	SACHET DE COLA 10 GRAMAS	GLUE	COLA	3
S	9920026	FIXADOR DE FUNDO 10 X 10 MM	BOOTOM FASTENER	FIJADOR DE FONDO	45
S3	9920038	SUPORTE CABIDE OBLONGO 20 MM	HANGER SUPPORT	SOPORTE DE PERCHERO	6
TA	9920060	CARTELA DE SILICONE	SILICONE CARTRIDGE	CARTÓN DE SILICONA	1
TB	9924014	CARTELA TAPA FUROS 18 MM ADESIVO	SCREW CAP	TAPA HUECOS	1
U	9924002	MINI SAPATA 15 MM	MINI SHOE	MINI ZAPATA	10
V	9920030	PORCA CILINDRICA 9 X 12 MM	CYLINDRICAL NUT	TUERCA CILINDRICA	66
W	9906001	PREGO 12X12 MM	NAIL	CLAVO	10
X	9906002	PREGO 9X9 MM	NAIL	CLAVO	180
Z	9920007	CANTONEIRA ZAMAC 12 MM	METAL ANGLE BRACKET	ESQUINERAS METALICAS	30

Acessórios/Accessories/Accessorios

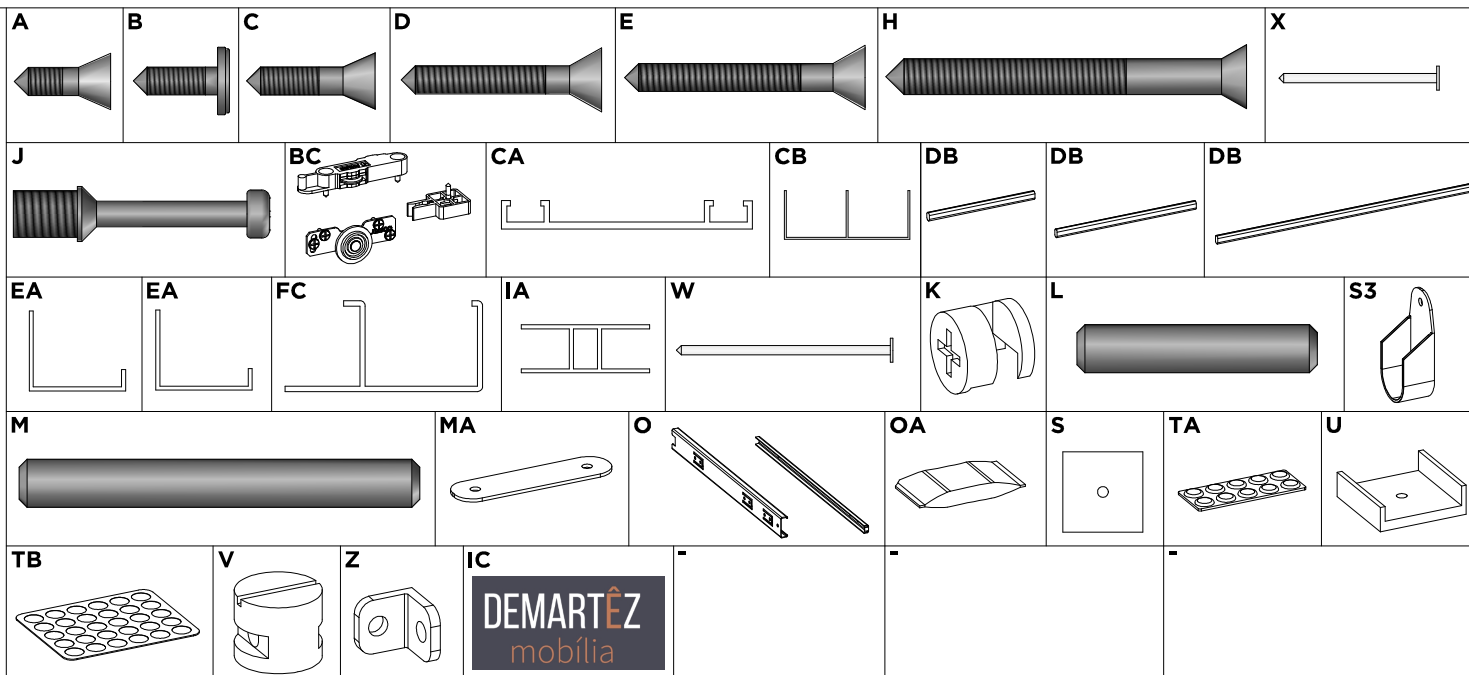

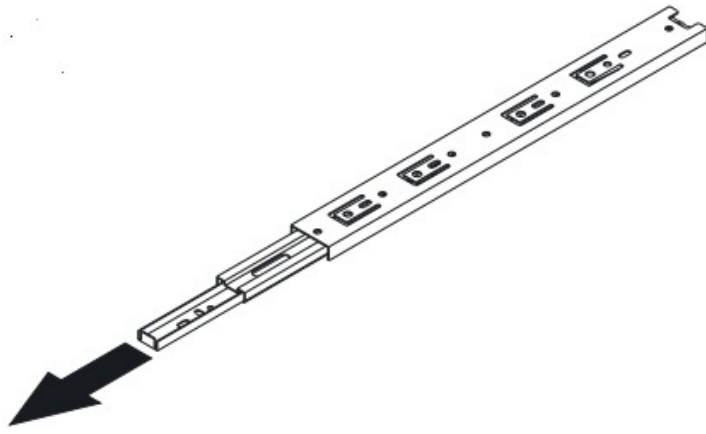

1º

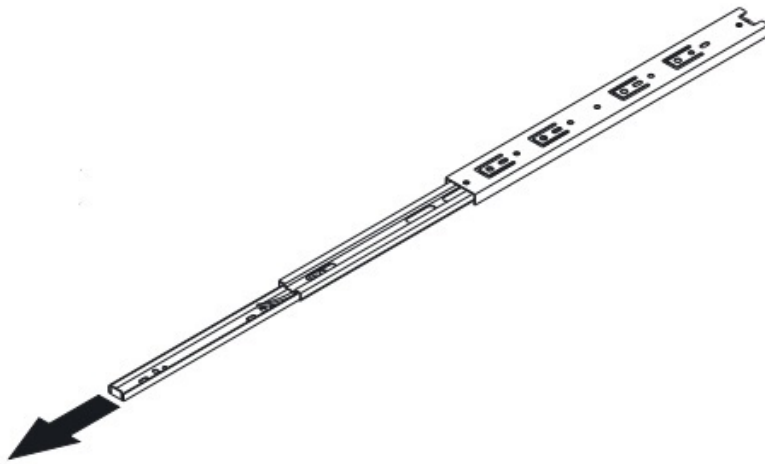

2º

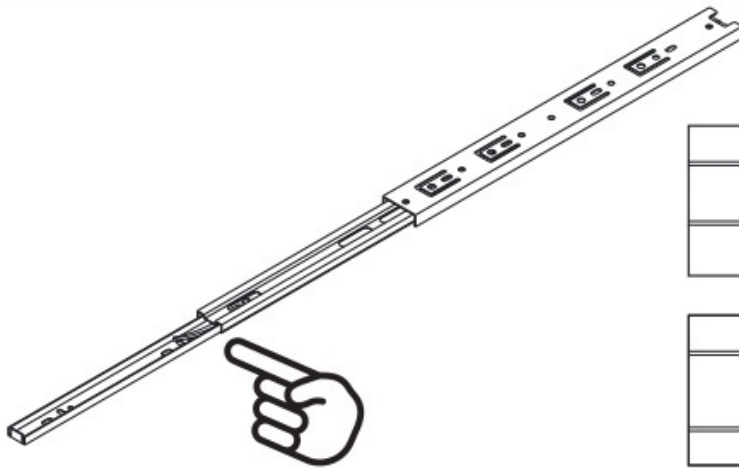

3º

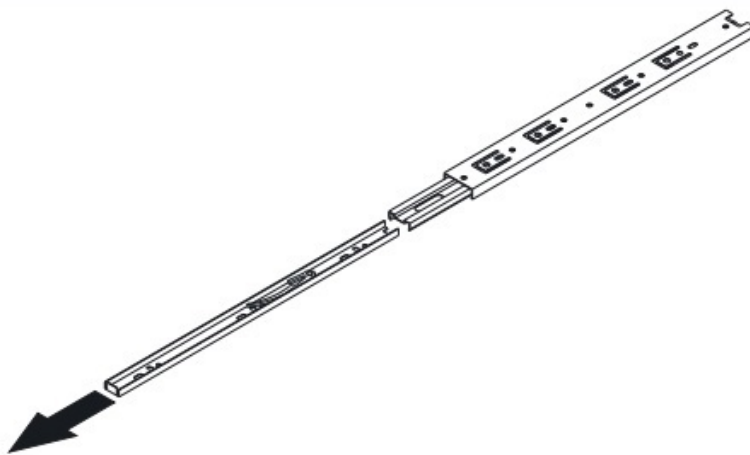

4º

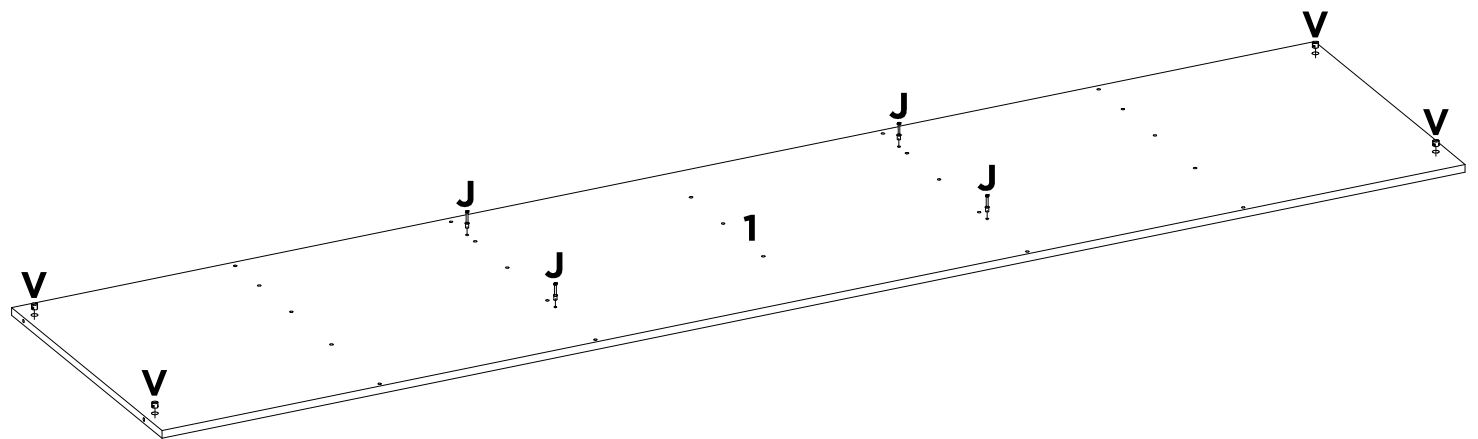

J	V	-	-	-	-	-	-
X4	X4	-	-	-	-	-	-

# 02

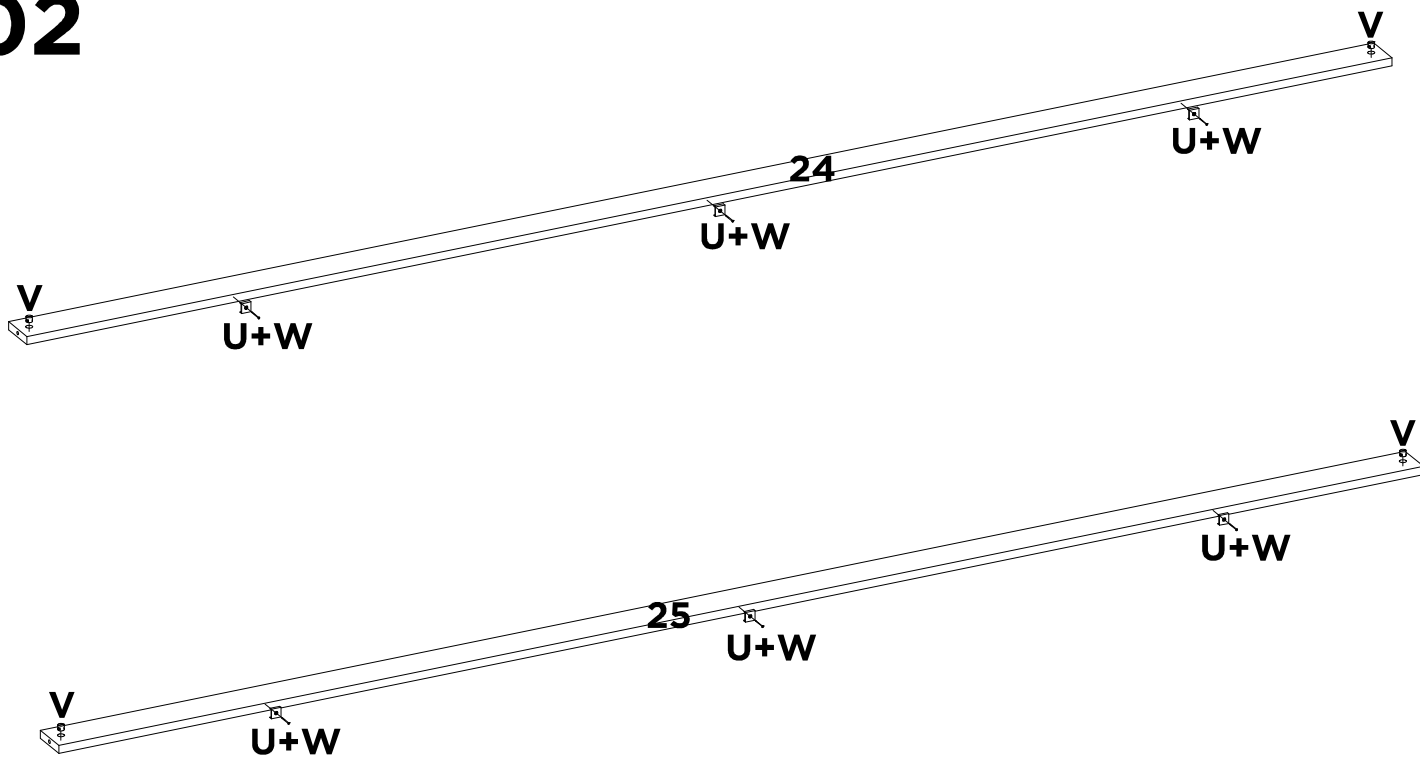

<b>U</b>	<b>V</b>	<b>W</b>	-	-	-	-	-
<b>X6</b>	<b>X4</b>	<b>X6</b>	-	-	-	-	-

# 02A

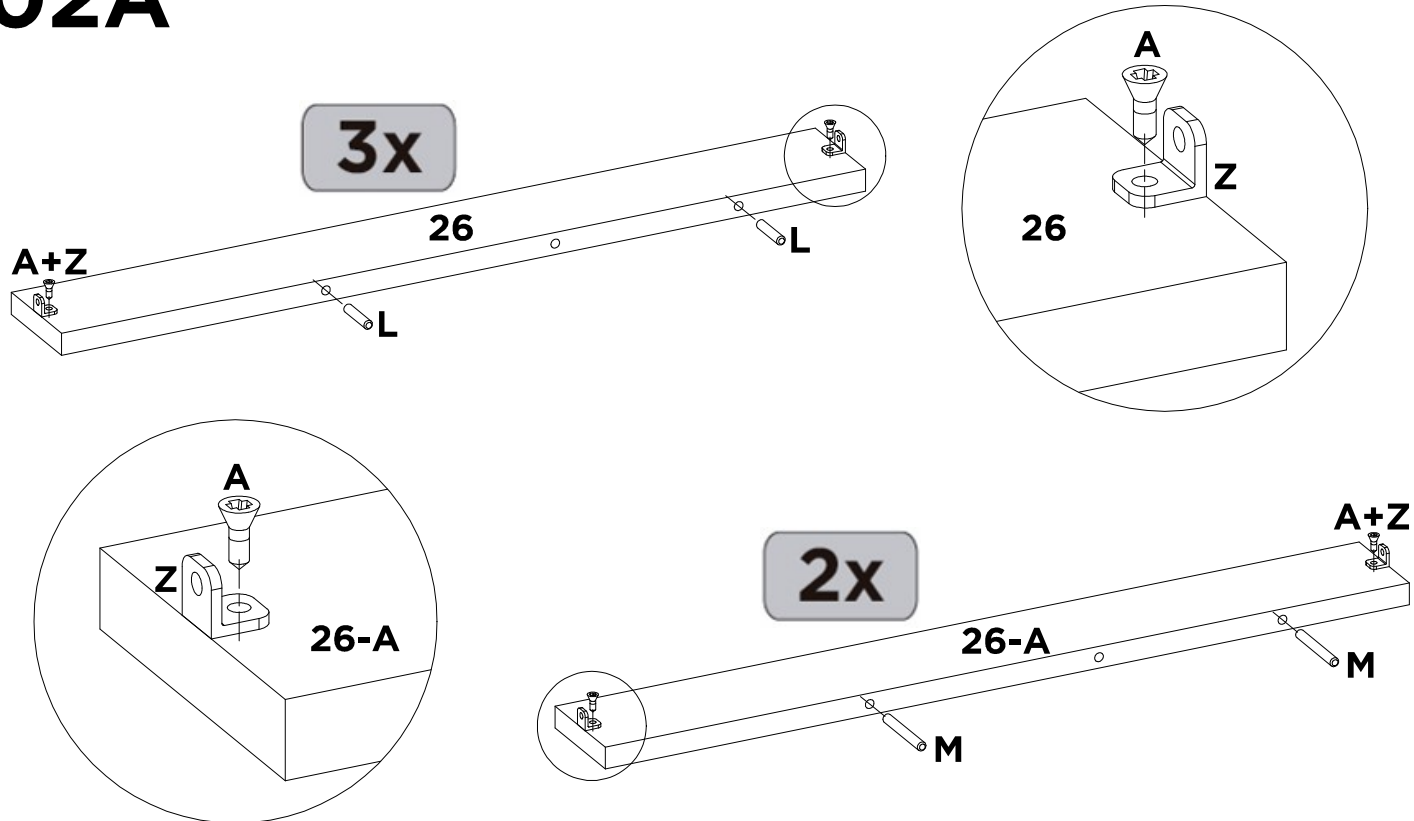

<b>A</b>	<b>L</b>	<b>M</b>	<b>Z</b>	-	-	-	-
<b>X10</b>	<b>X6</b>	<b>X4</b>	<b>X10</b>	-	-	-	-

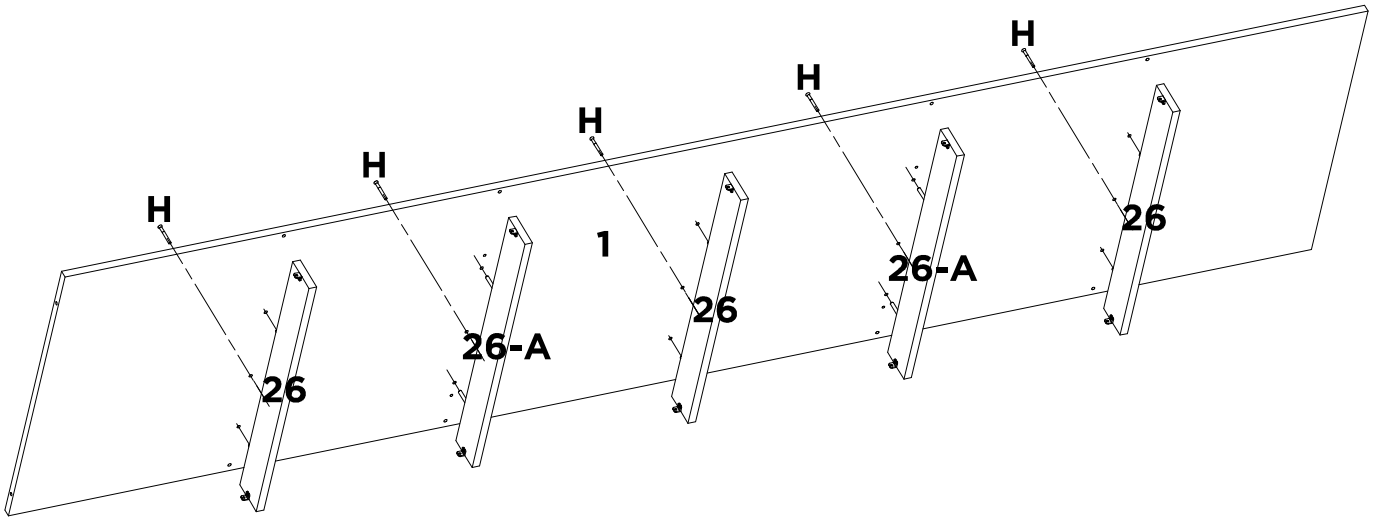

H	-	-	-	-	-	-	-
X5	-	-	-	-	-	-	-

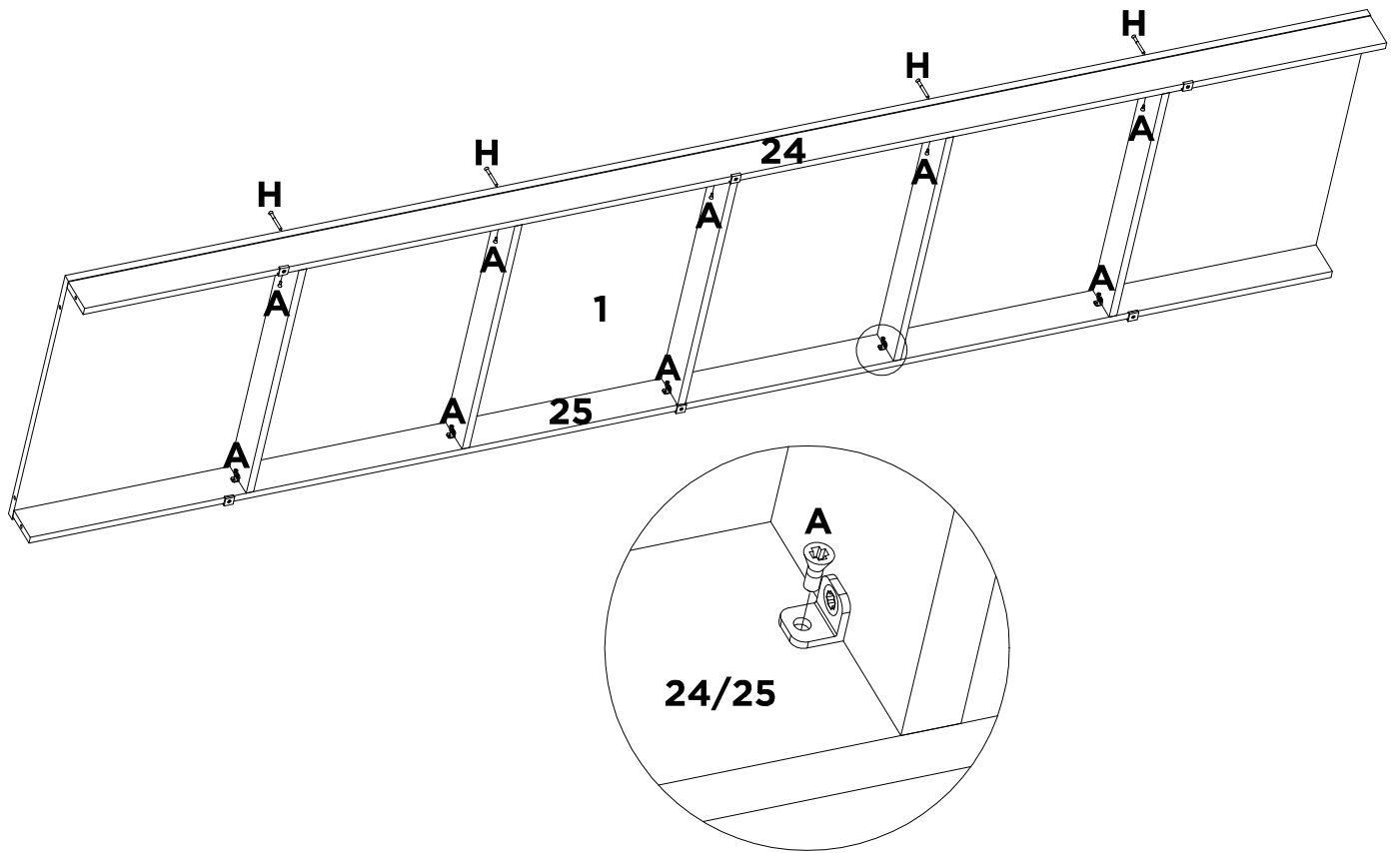

<b>A</b> <b>X10</b>	<b>H</b> <b>X8</b>	-	-	-	-	-	-
------------------------	-----------------------	---	---	---	---	---	---



# 05

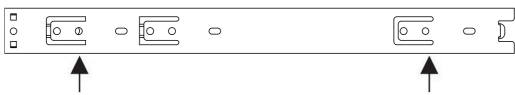
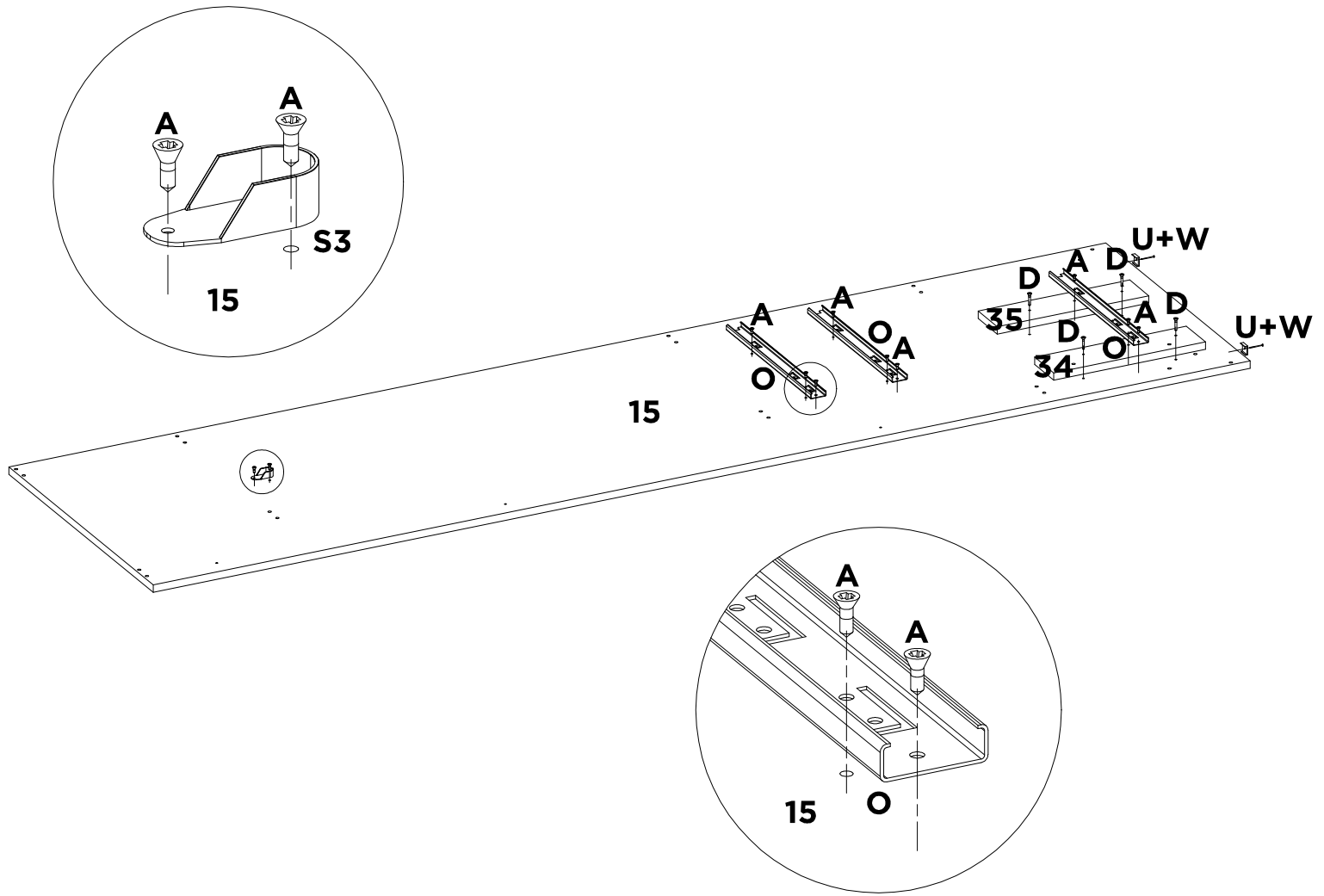

<b>A</b>	<b>D</b>	<b>O</b>	<b>S3</b>	<b>U</b>	<b>W</b>	-	-
<b>X11</b>	<b>X4</b>	<b>X3</b>	<b>X1</b>	<b>X2</b>	<b>X2</b>	-	-

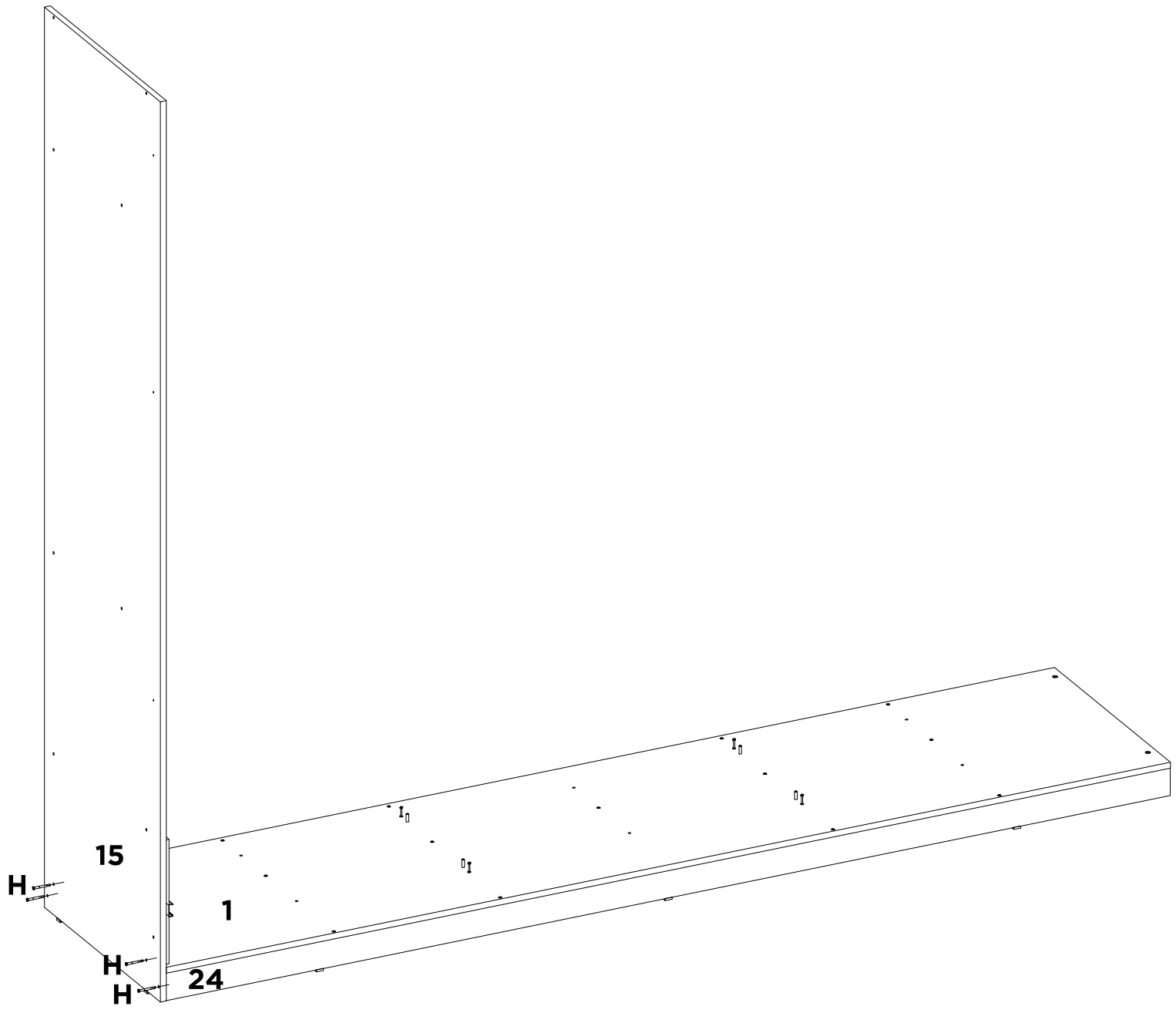

H	-	-	-	-	-	-	-
X4	-	-	-	-	-	-	-

# 07

2x

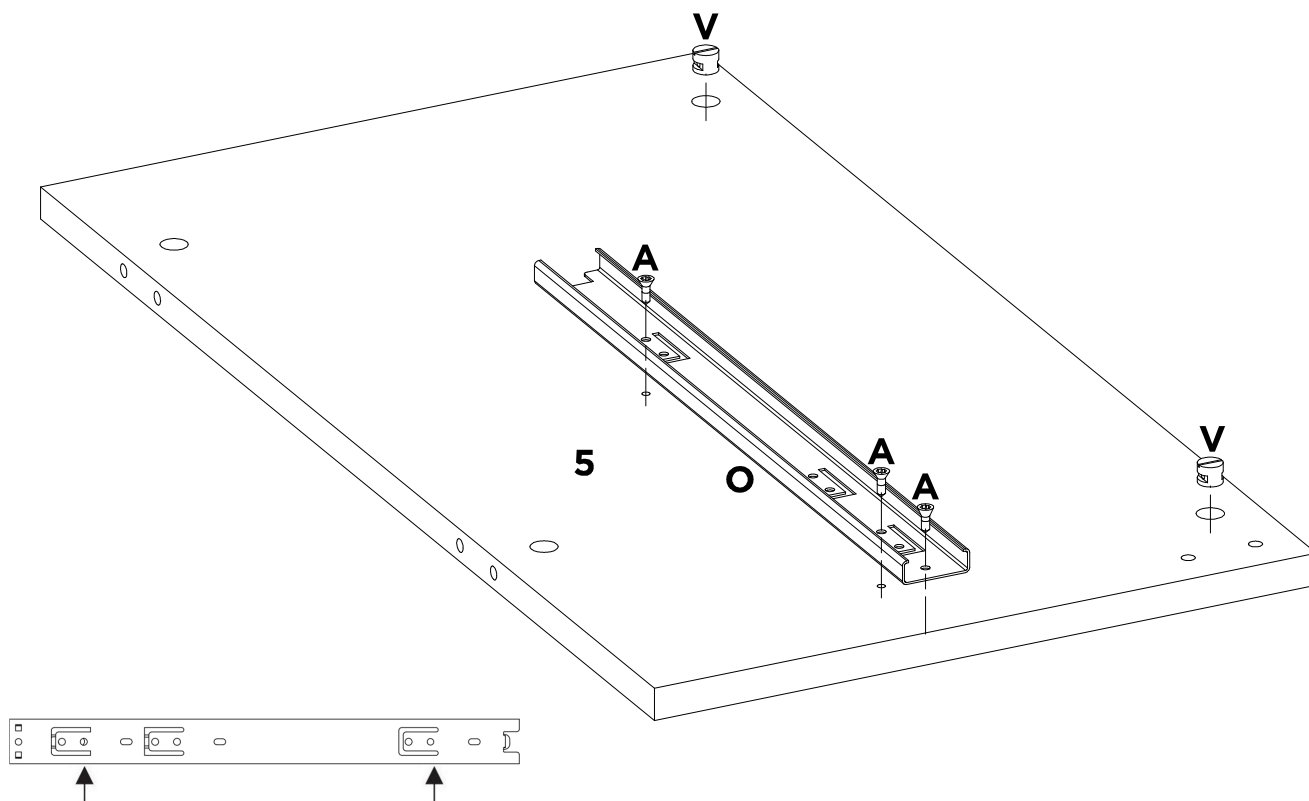

<b>A</b>	<b>O</b>	<b>V</b>	-	-	-	-	-
<b>X6</b>	<b>X2</b>	<b>X4</b>	-	-	-	-	-

# 07A

2x

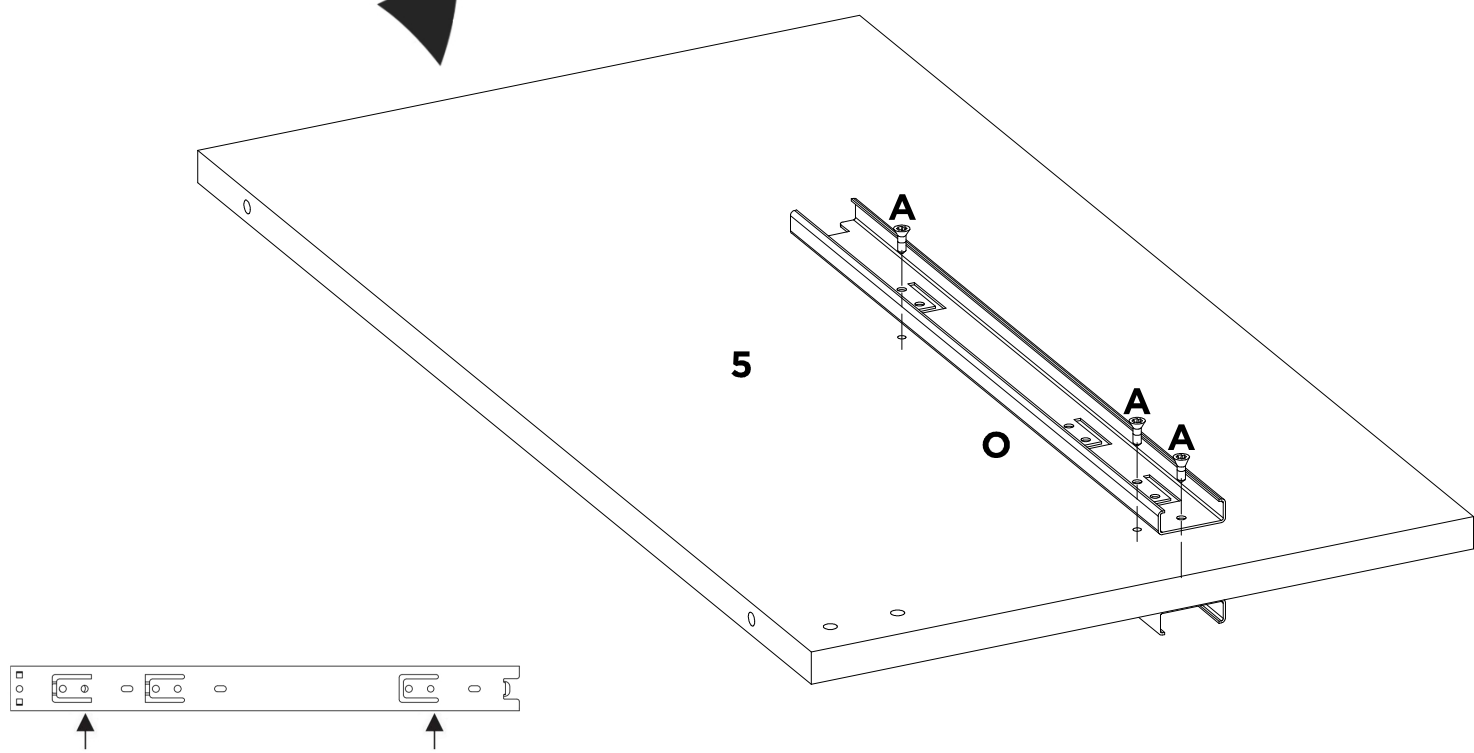

<b>A</b>	<b>O</b>	-	-	-	-	-	-
<b>X6</b>	<b>X2</b>	-	-	-	-	-	-

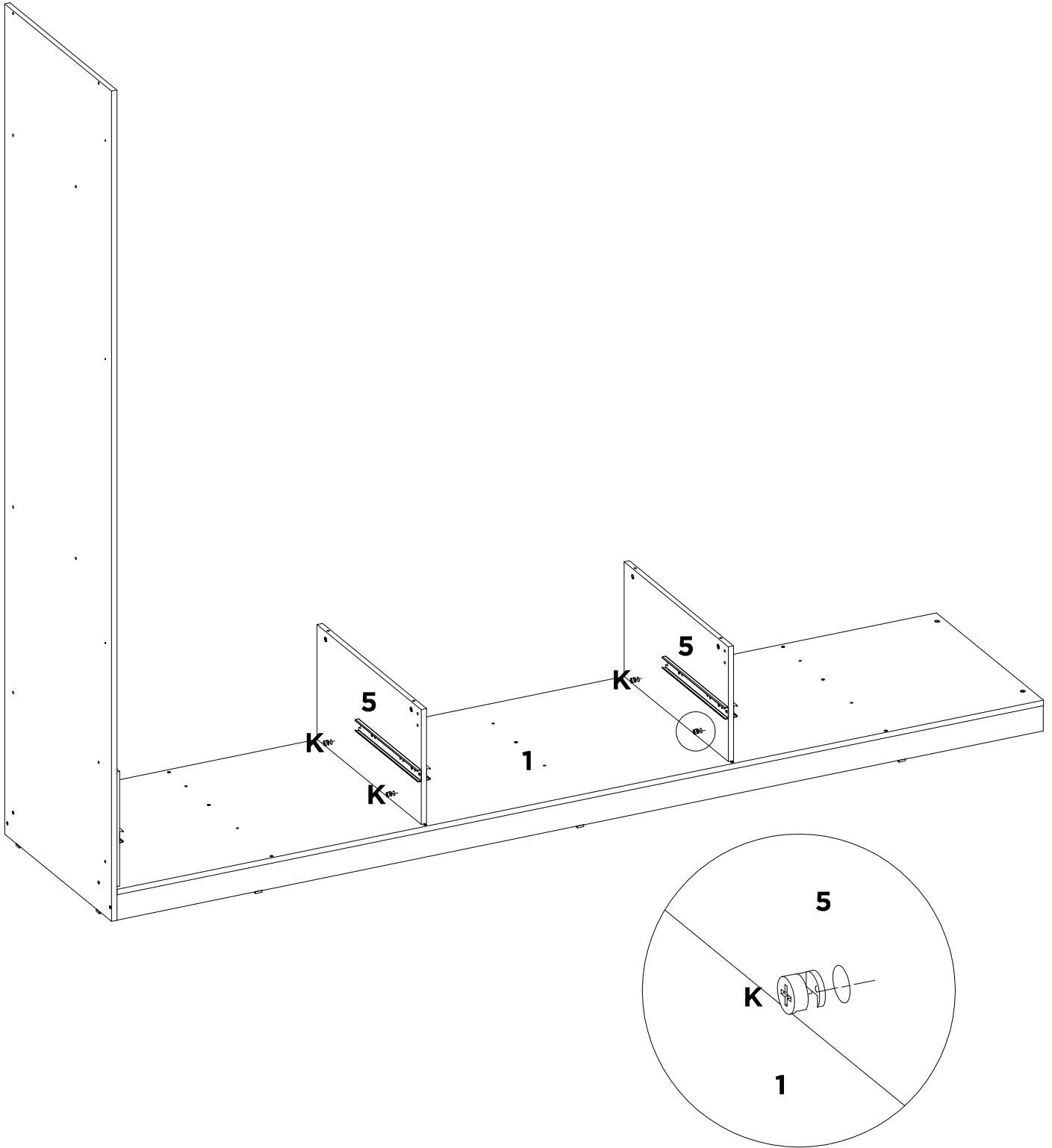

<b>K</b>	-	-	-	-	-	-	-
<b>X4</b>	-	-	-	-	-	-	-

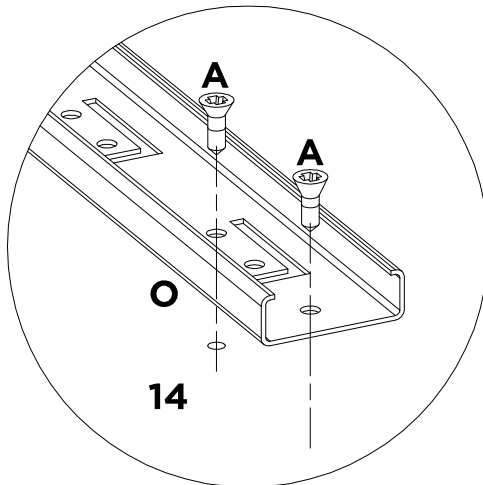
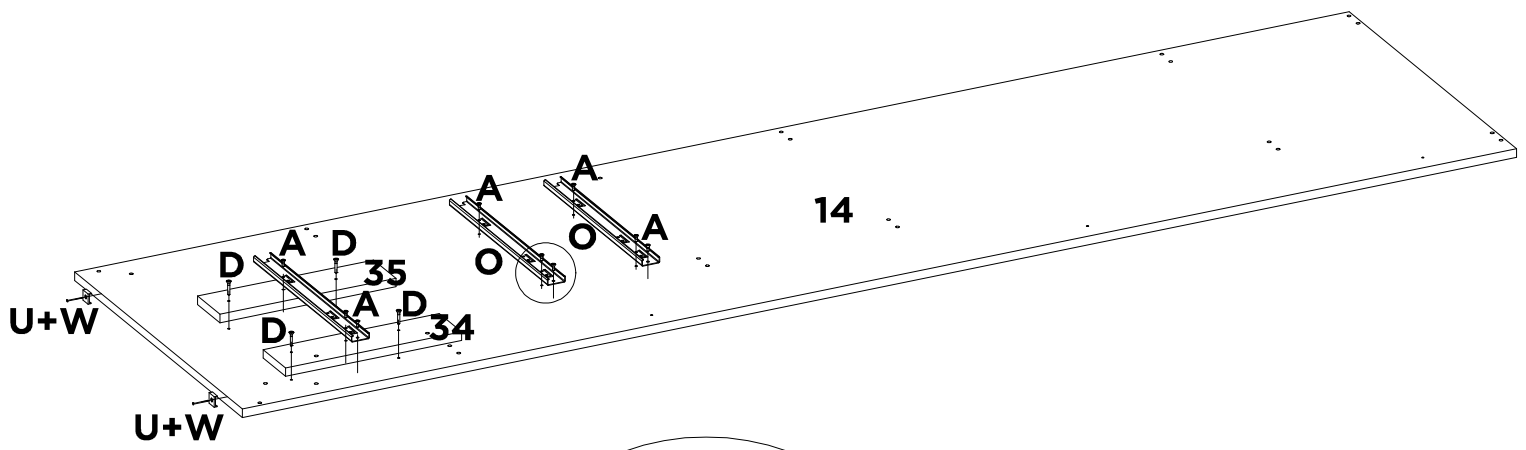

<b>A</b>	<b>D</b>	<b>O</b>	<b>U</b>	<b>W</b>	-	-	-
<b>X9</b>	<b>X4</b>	<b>X3</b>	<b>X2</b>	<b>X2</b>	-	-	-

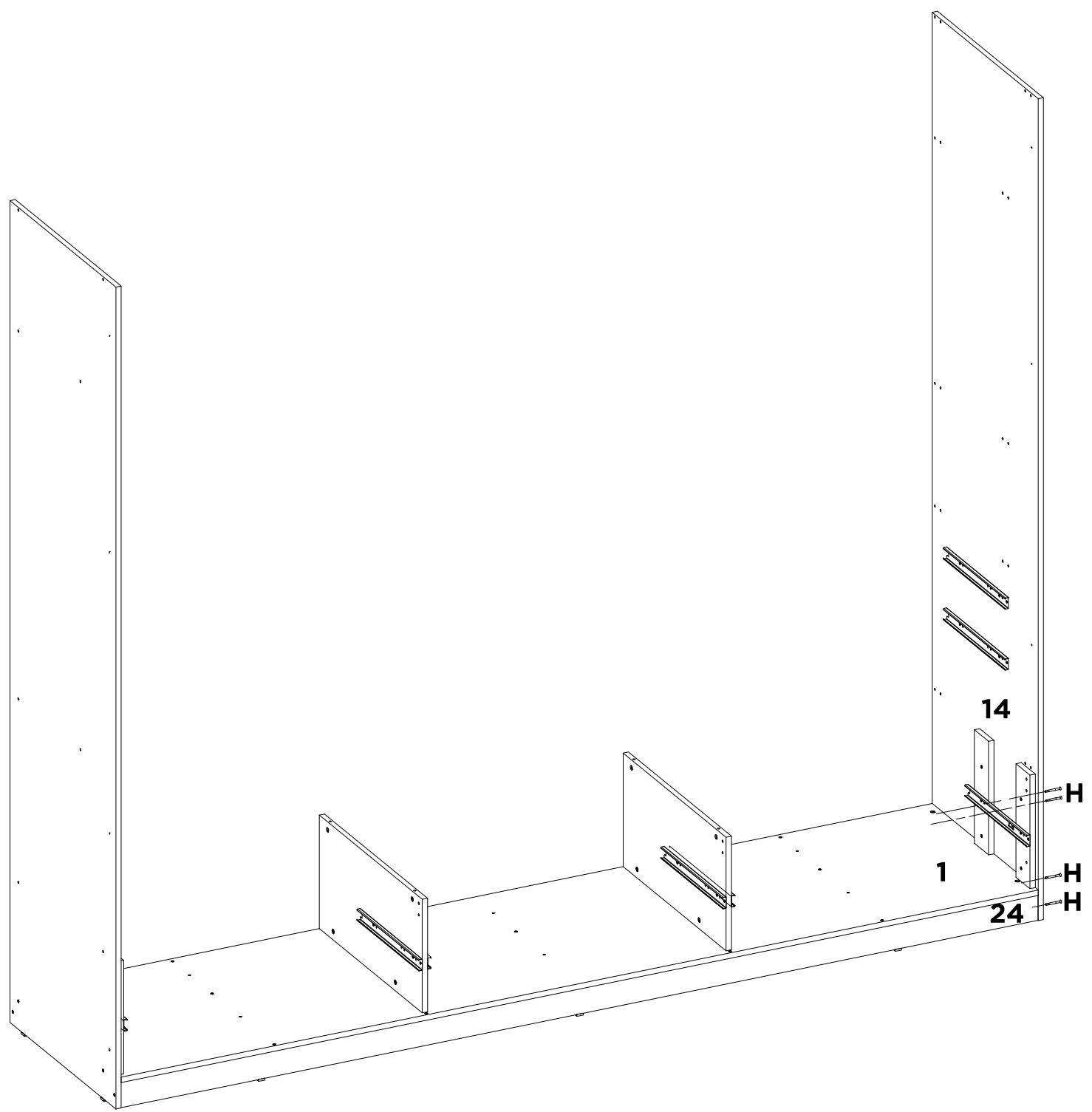

<b>H</b>	-	-	-	-	-	-	-
<b>X4</b>	-	-	-	-	-	-	-

# 11

2x

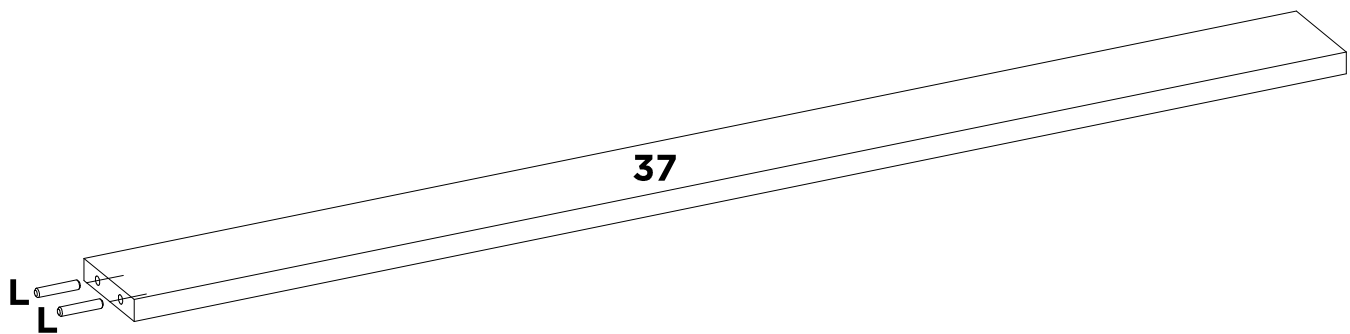

L	-	-	-	-	-	-	-
X4	-	-	-	-	-	-	-

# 11A

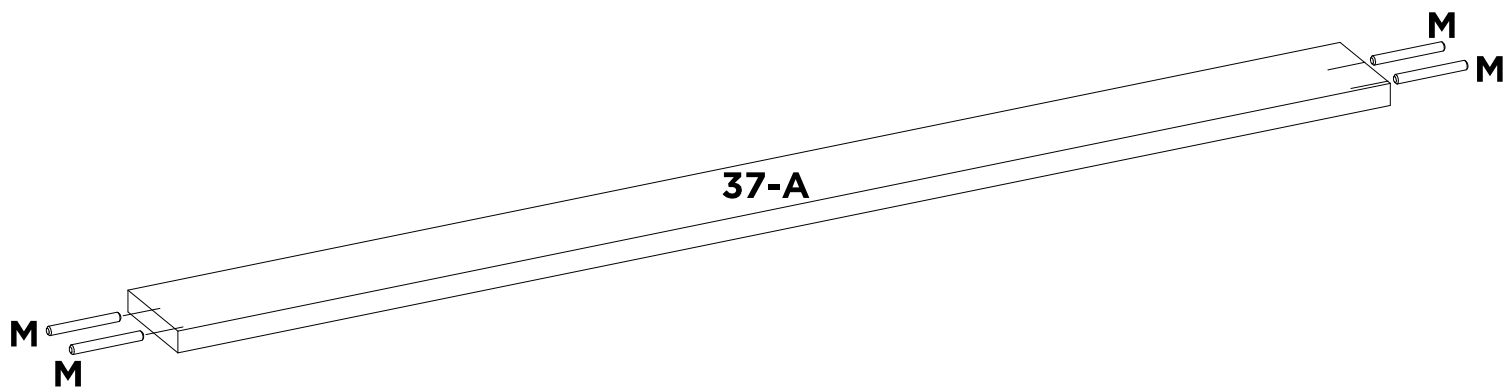

M	-	-	-	-	-	-	-
X4	-	-	-	-	-	-	-

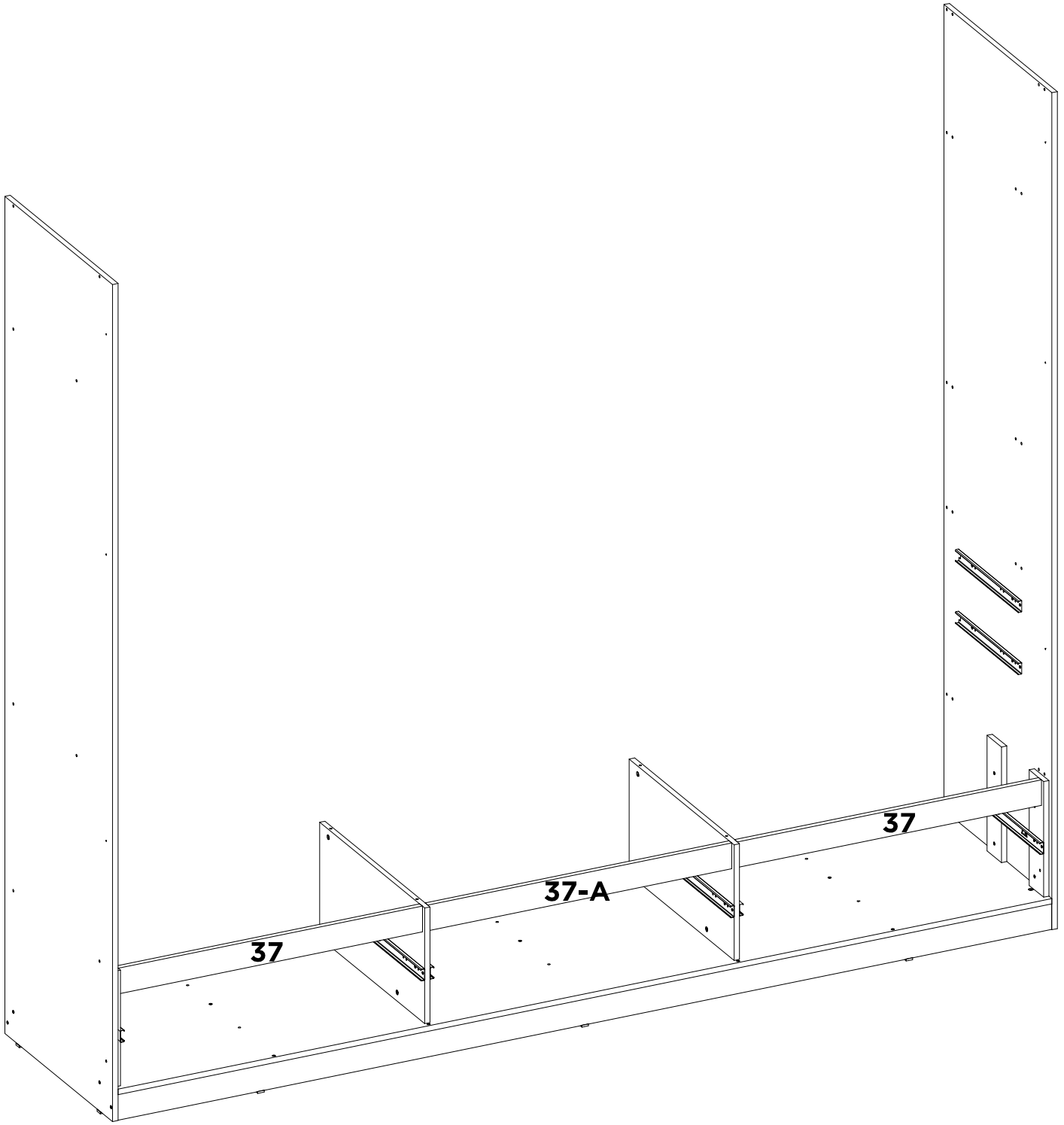

■	■	■	■	■	■	■	■
■	■	■	■	■	■	■	■



# 13

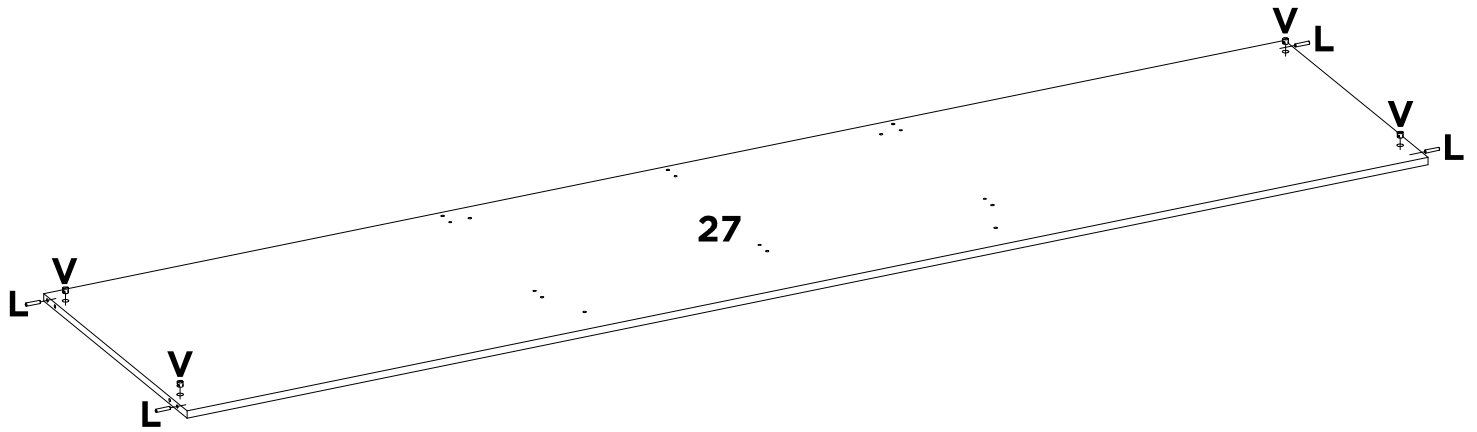

L	V	-	-	-	-	-	-
X4	X4	-	-	-	-	-	-

# 13A

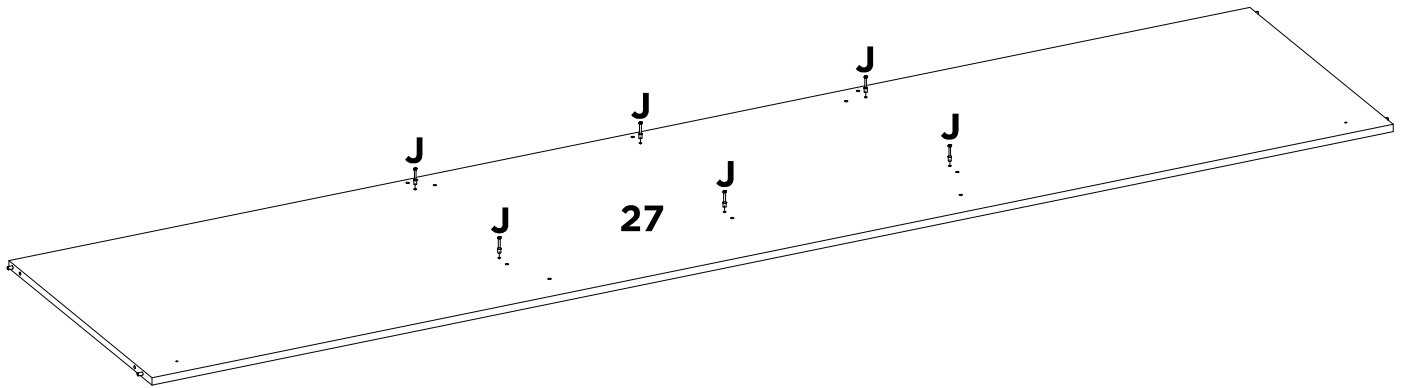

J	-	-	-	-	-	-	-
X6	-	-	-	-	-	-	-

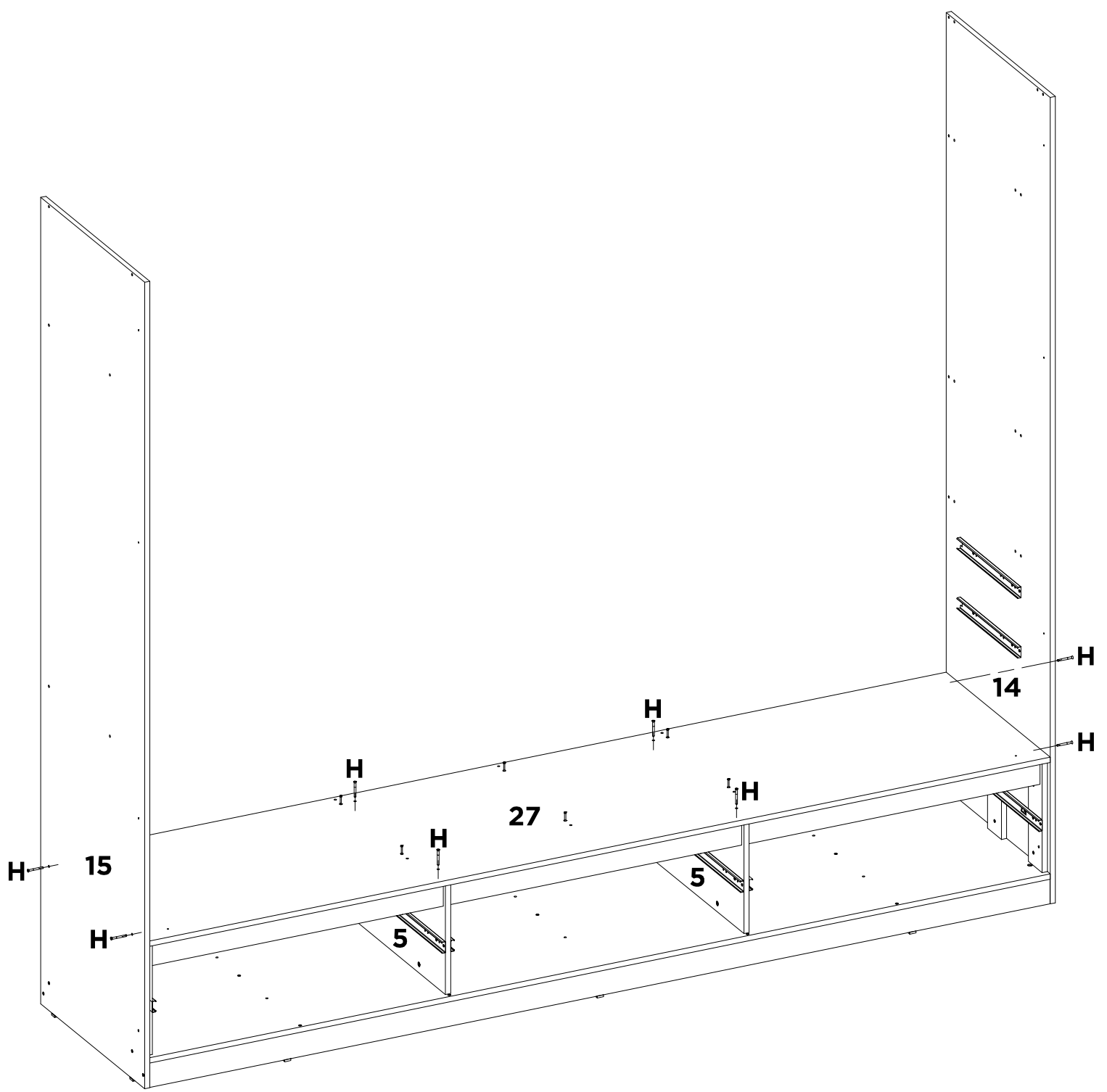

H	-	-	-	-	-	-	-
X8	-	-	-	-	-	-	-

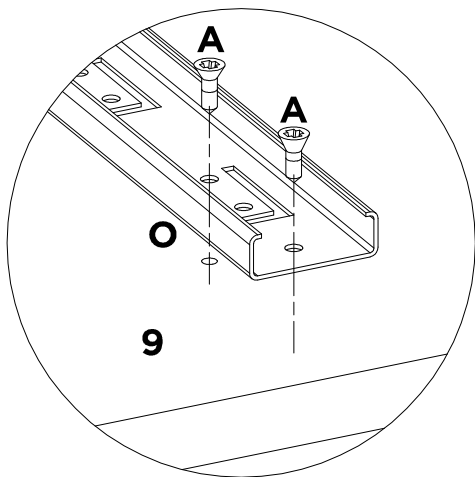
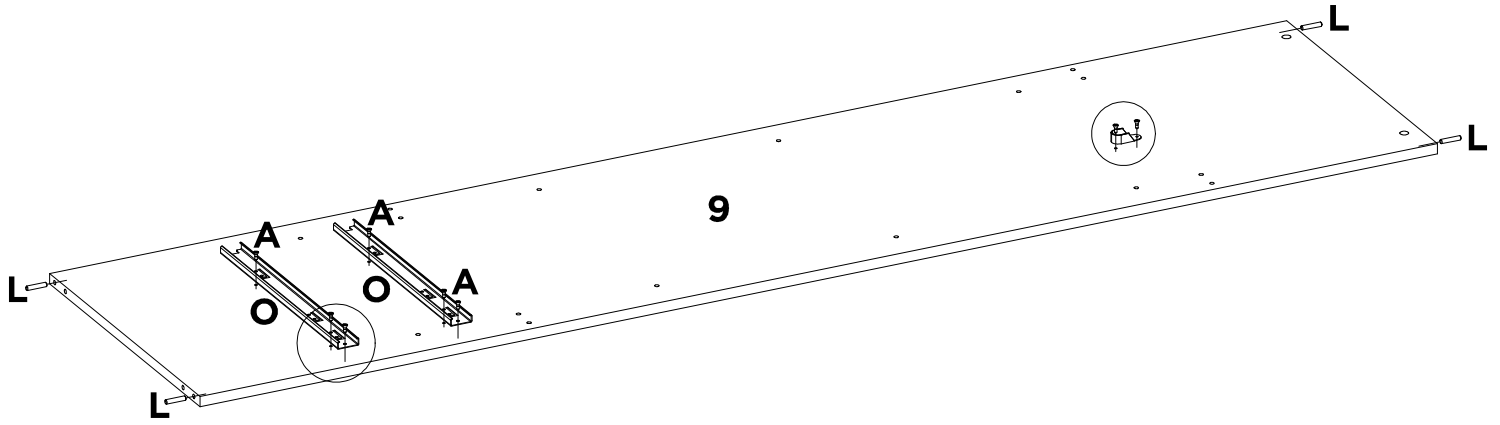
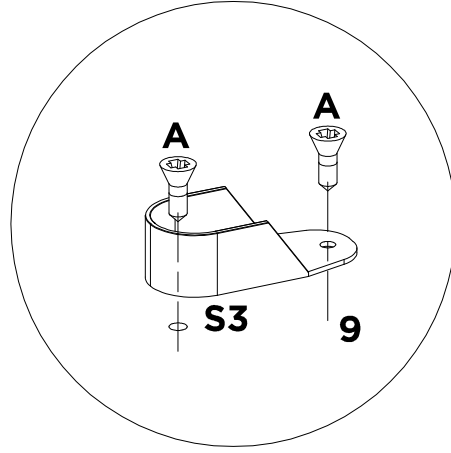

<b>A</b>	<b>L</b>	<b>O</b>	<b>S3</b>	-	-	-	-
<b>X8</b>	<b>X4</b>	<b>X2</b>	<b>X1</b>	-	-	-	-

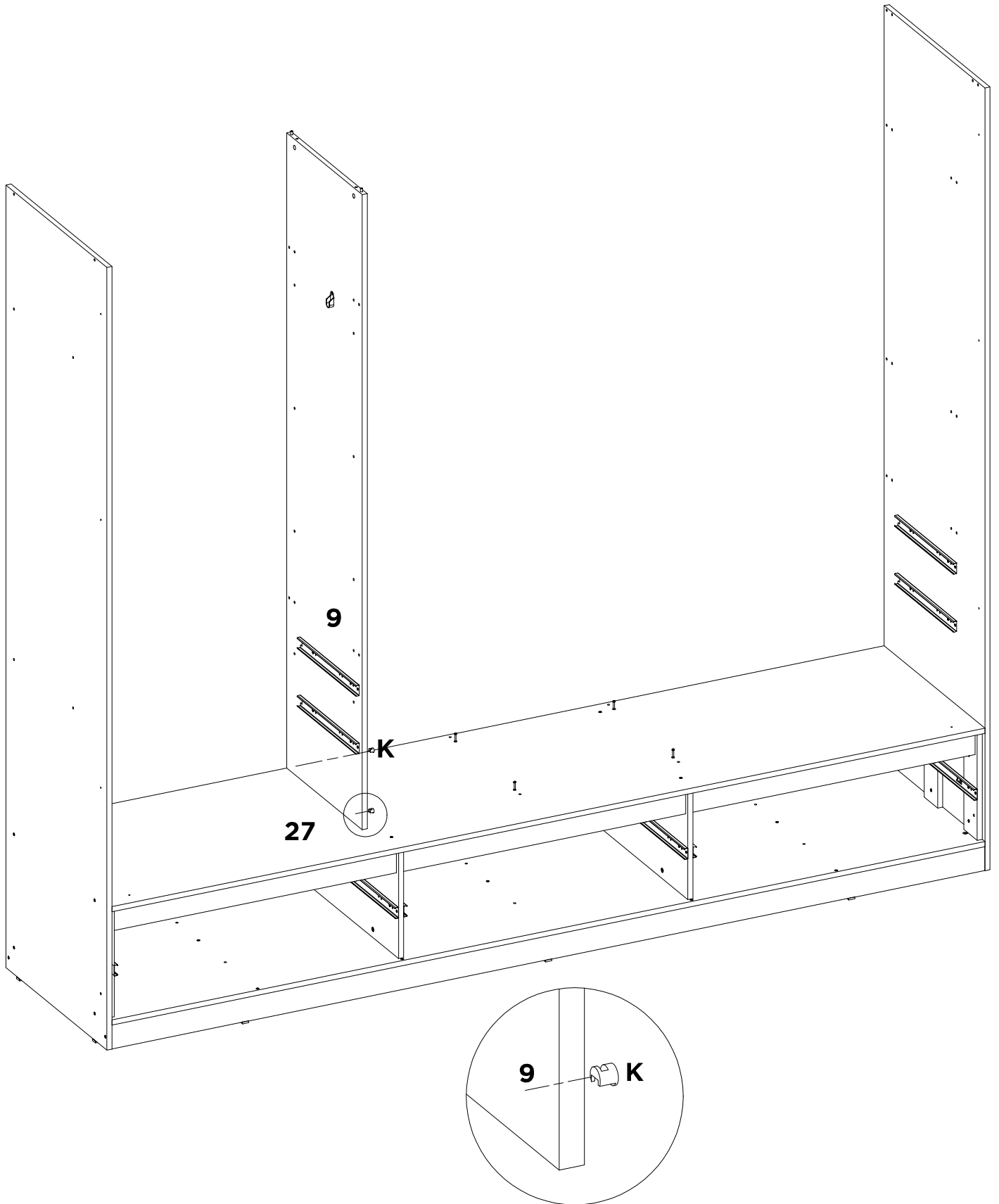

<b>K</b>	-	-	-	-	-	-	-
<b>X2</b>	-	-	-	-	-	-	-

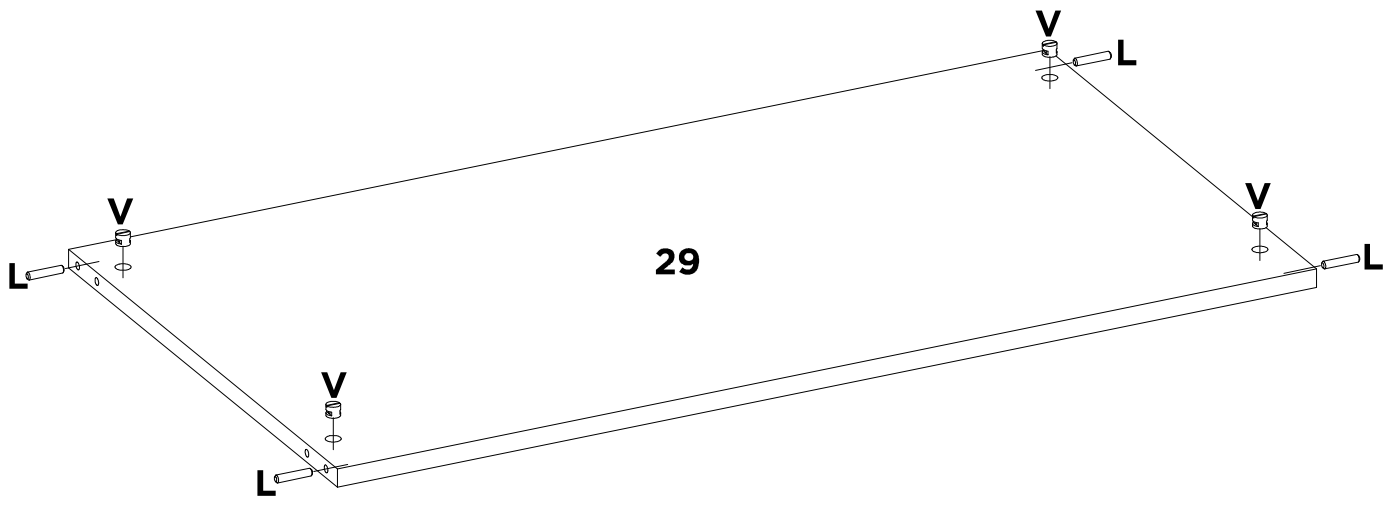

L	V	-	-	-	-	-	-
X4	X4	-	-	-	-	-	-

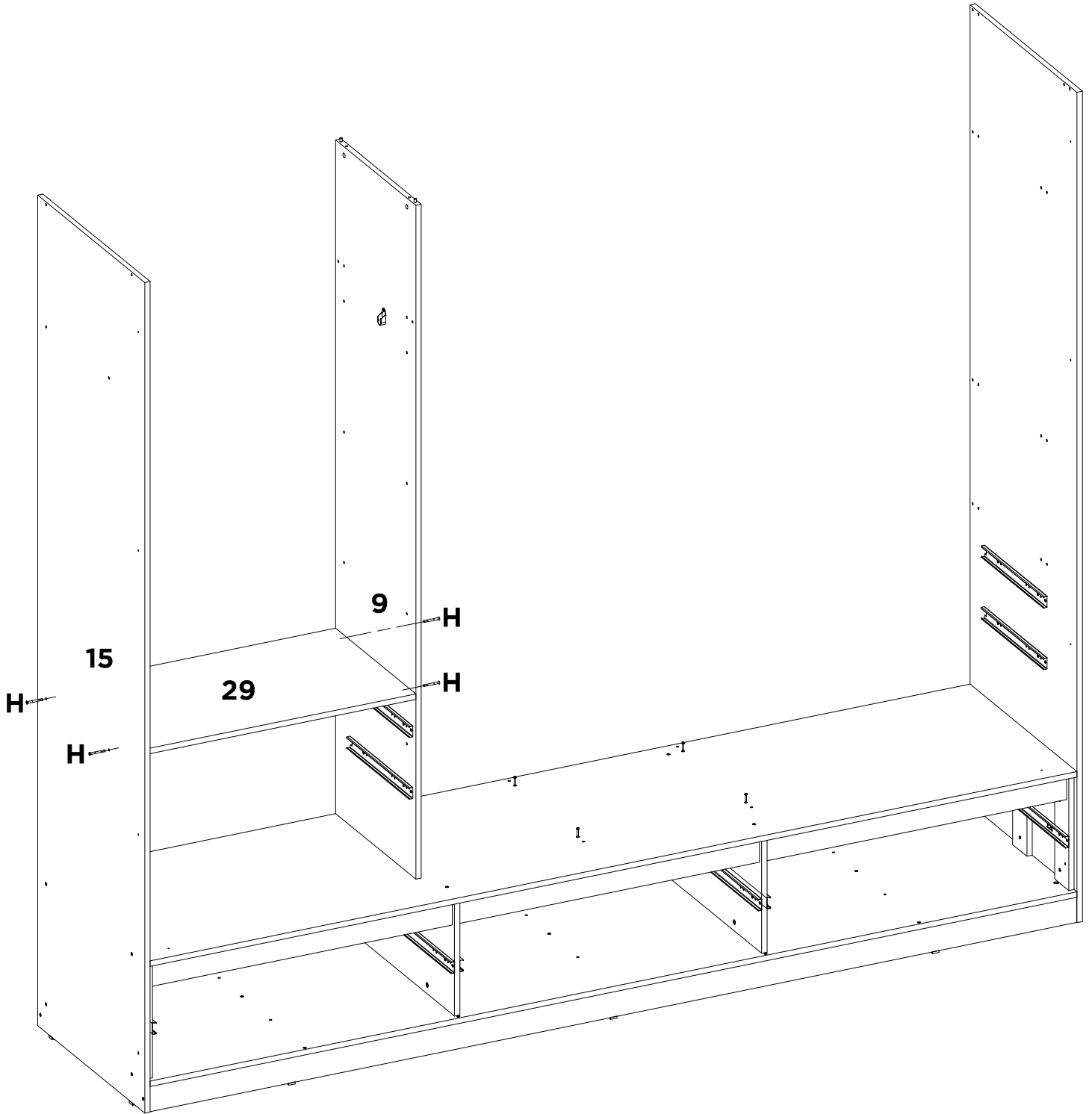

H	-	-	-	-	-	-	-
X4	-	-	-	-	-	-	-

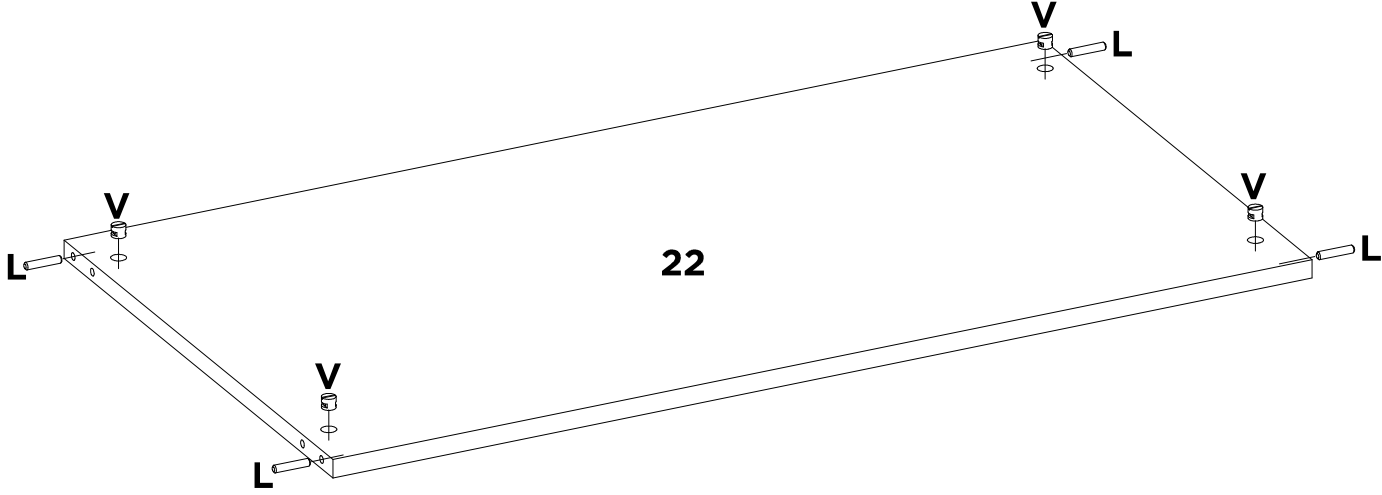

L	V	-	-	-	-	-	-
X4	X4	-	-	-	-	-	-

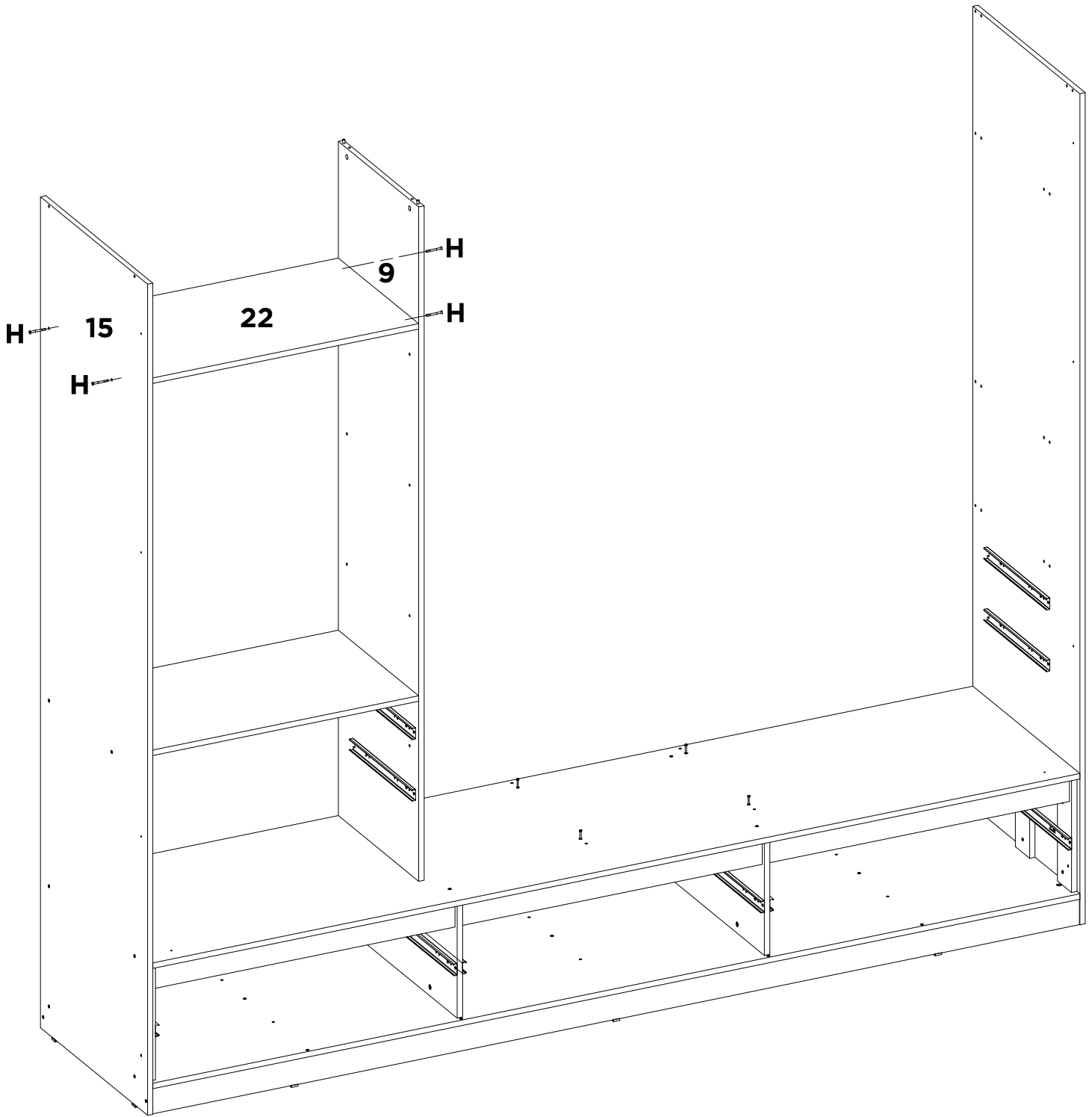

<b>H</b>	-	-	-	-	-	-	-
<b>X4</b>	-	-	-	-	-	-	-



# 21

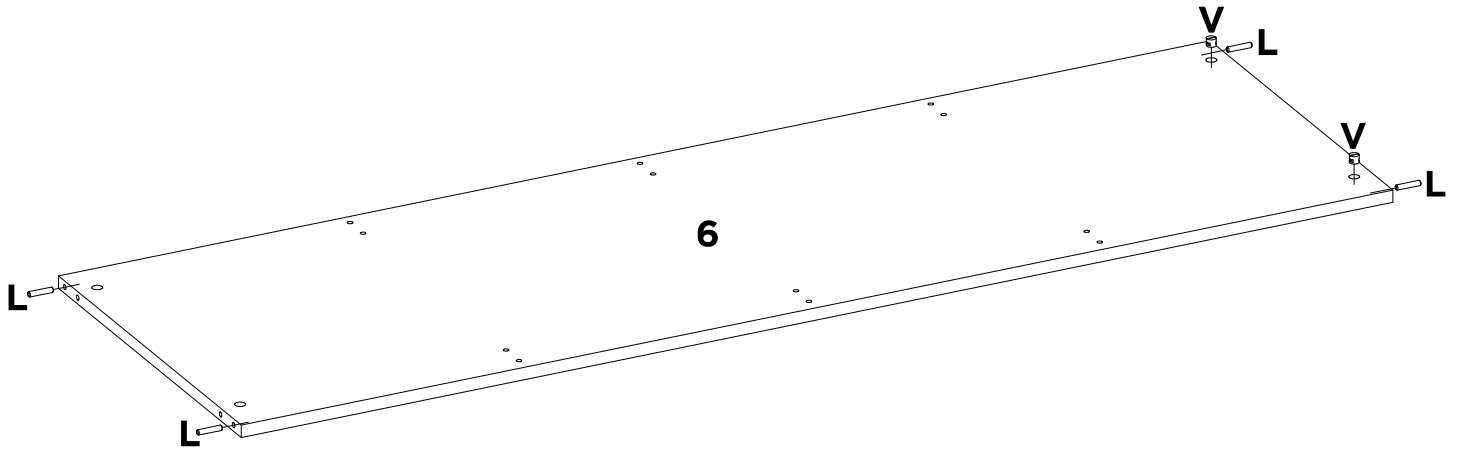

L	V	-	-	-	-	-	-
X4	X2	-	-	-	-	-	-

# 21A

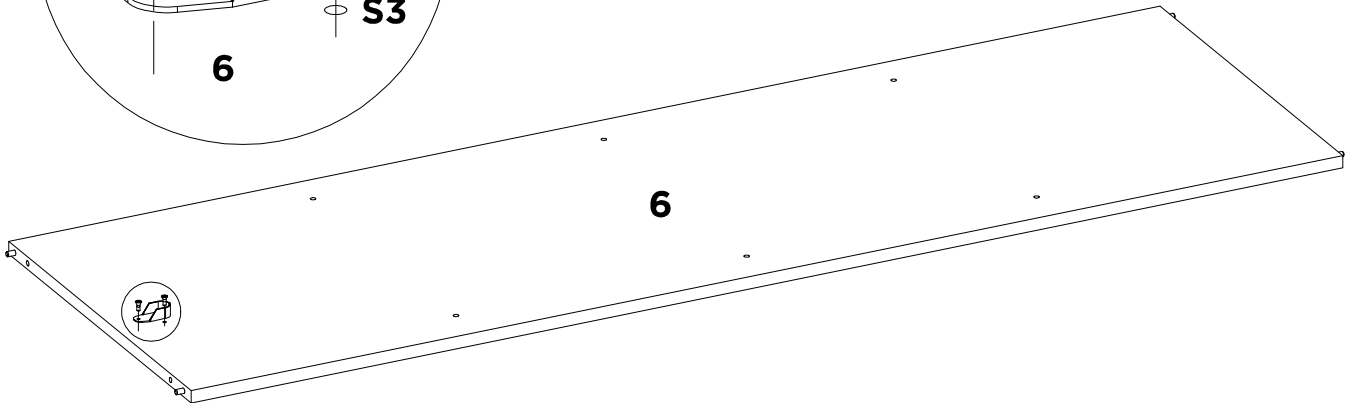
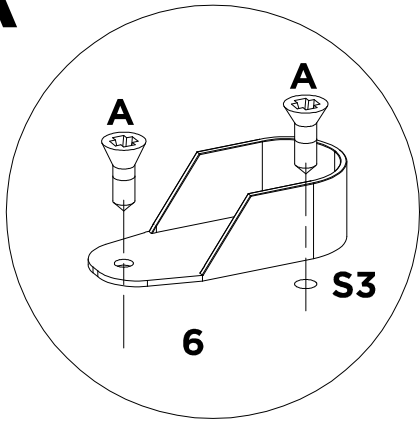

A	S3	-	-	-	-	-	-
X2	X1	-	-	-	-	-	-

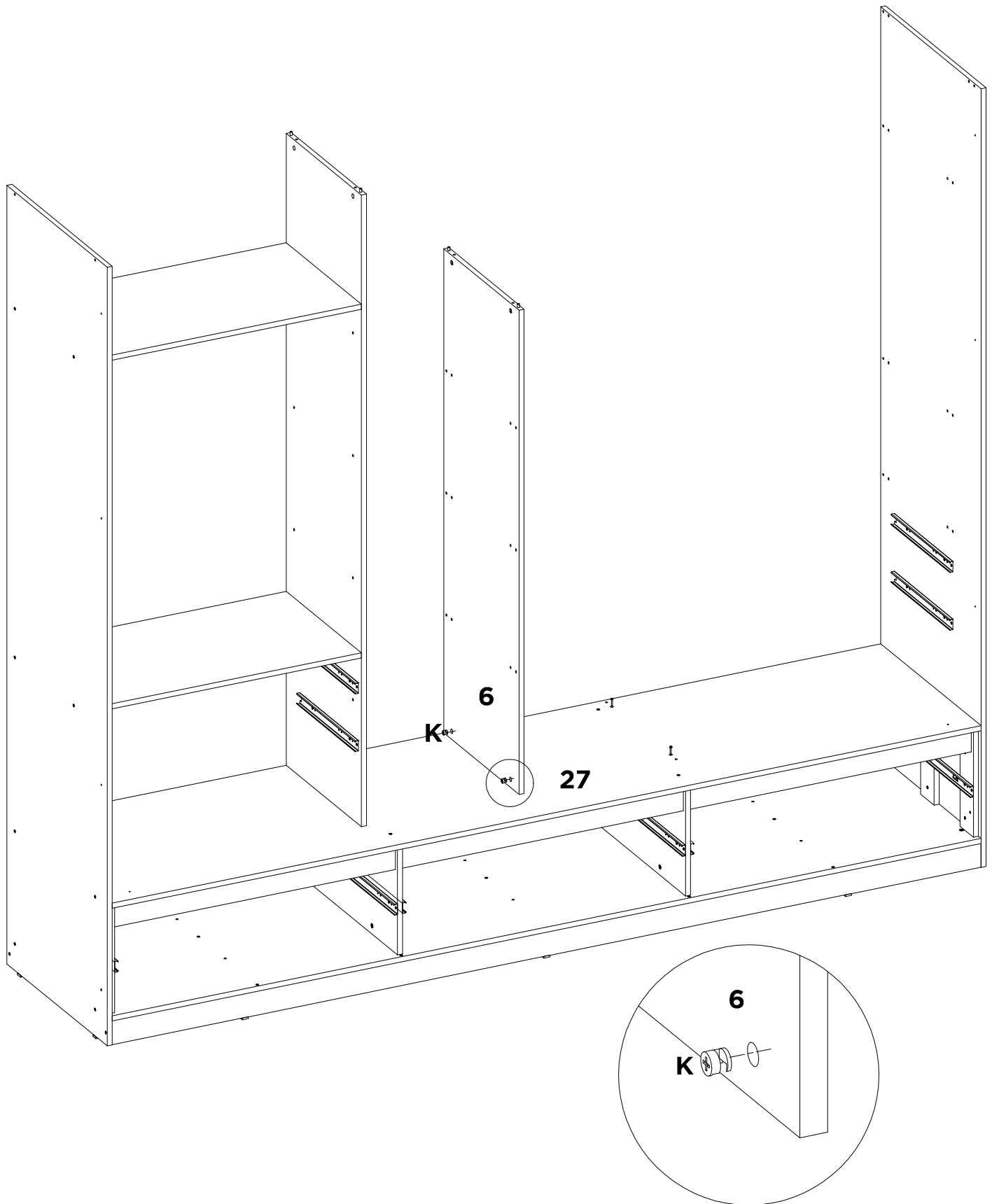

<b>K</b>	-	-	-	-	-	-	-
<b>X2</b>	-	-	-	-	-	-	-

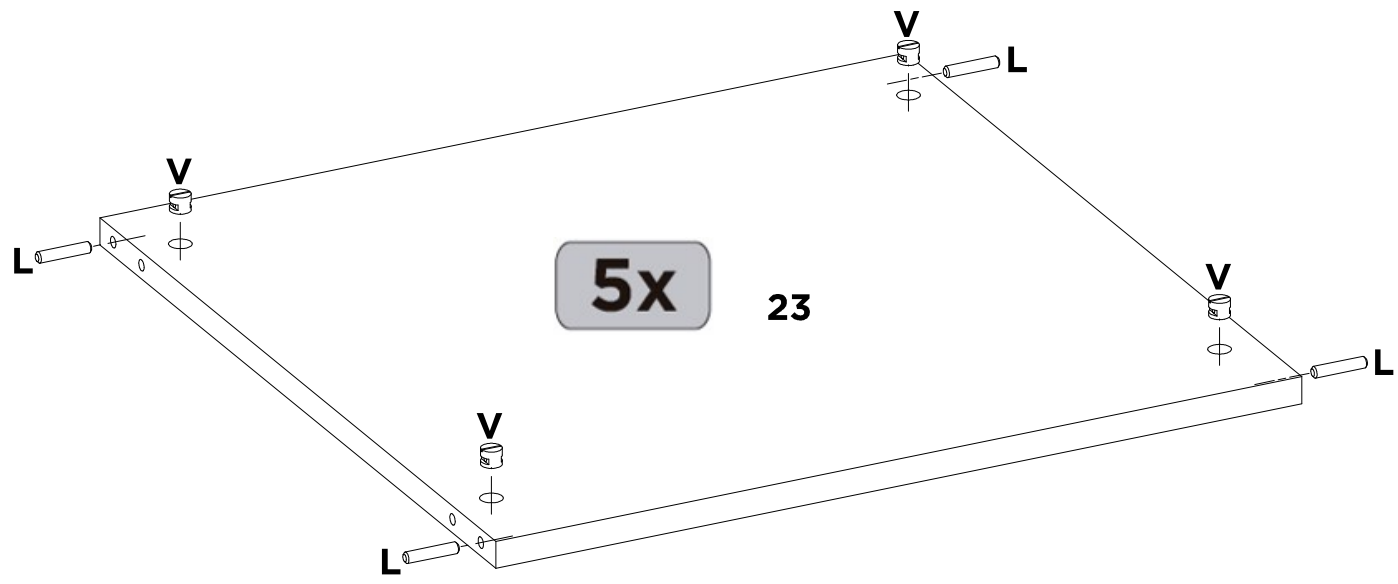

<b>L</b>	<b>V</b>	-	-	-	-	-	-
<b>X20</b>	<b>X20</b>	-	-	-	-	-	-

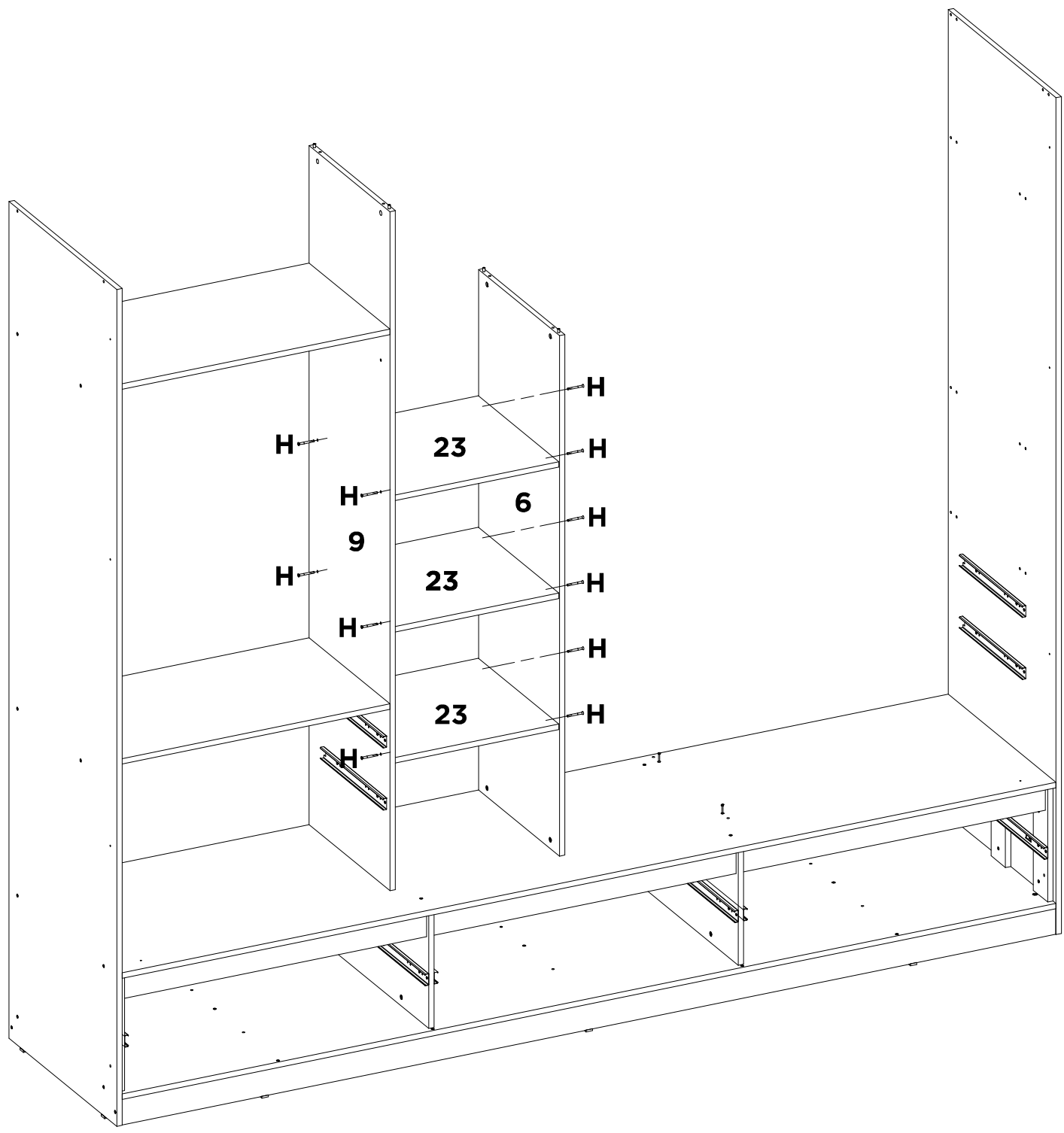

H	-	-	-	-	-	-	-
X12	-	-	-	-	-	-	-

# 25

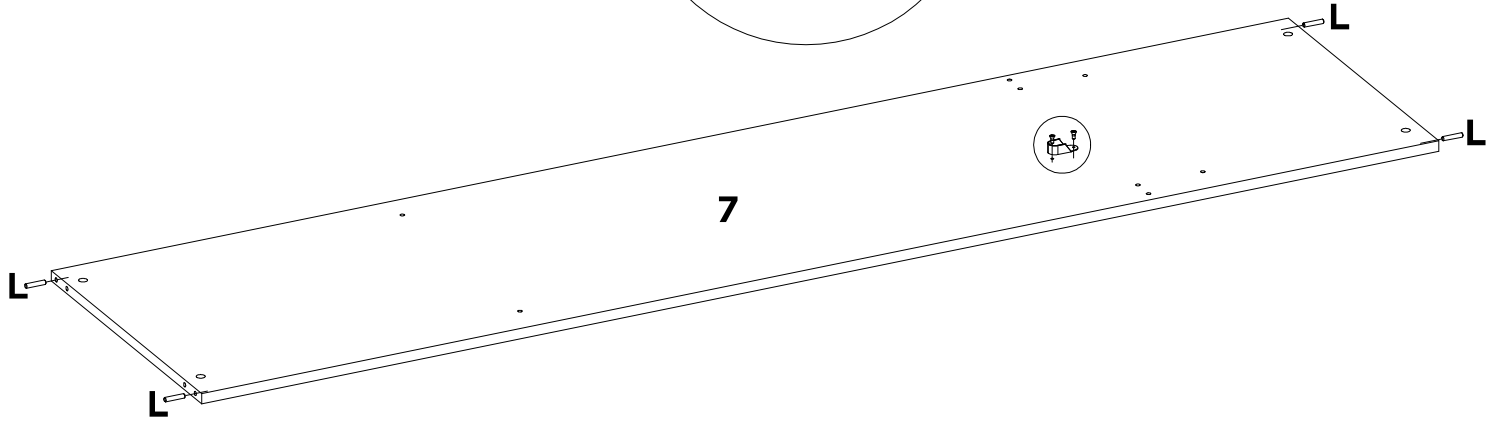
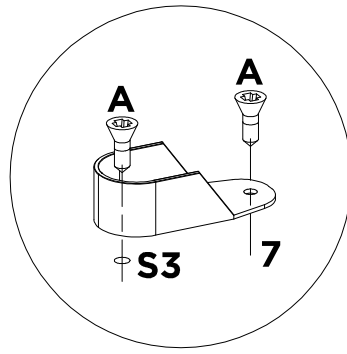

<b>A</b>	<b>L</b>	<b>S3</b>	-	-	-	-	-
<b>X2</b>	<b>X4</b>	<b>X1</b>	-	-	-	-	-

# 25A

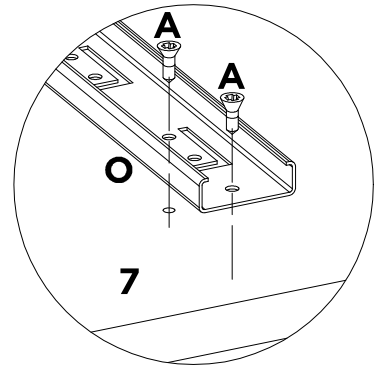
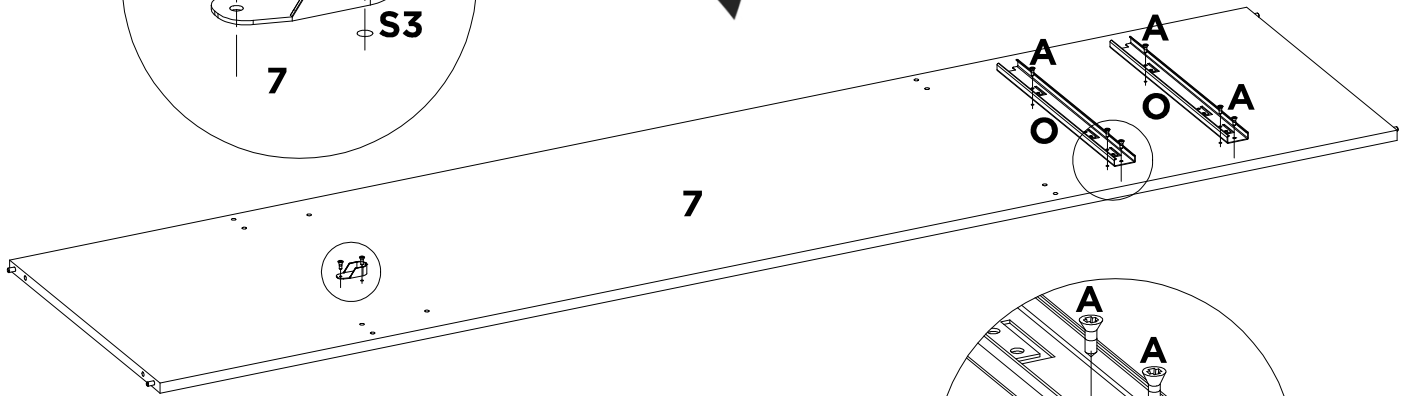
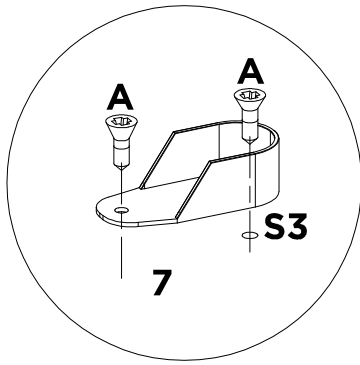

<b>A</b>	<b>O</b>	<b>S3</b>	-	-	-	-	-
<b>X8</b>	<b>X2</b>	<b>X1</b>	-	-	-	-	-

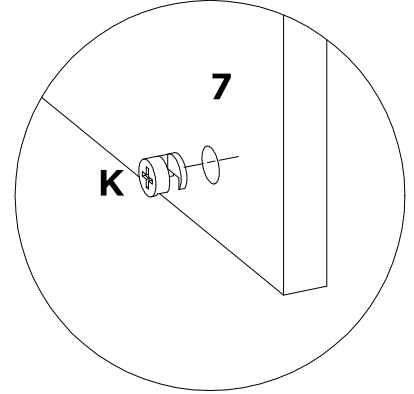
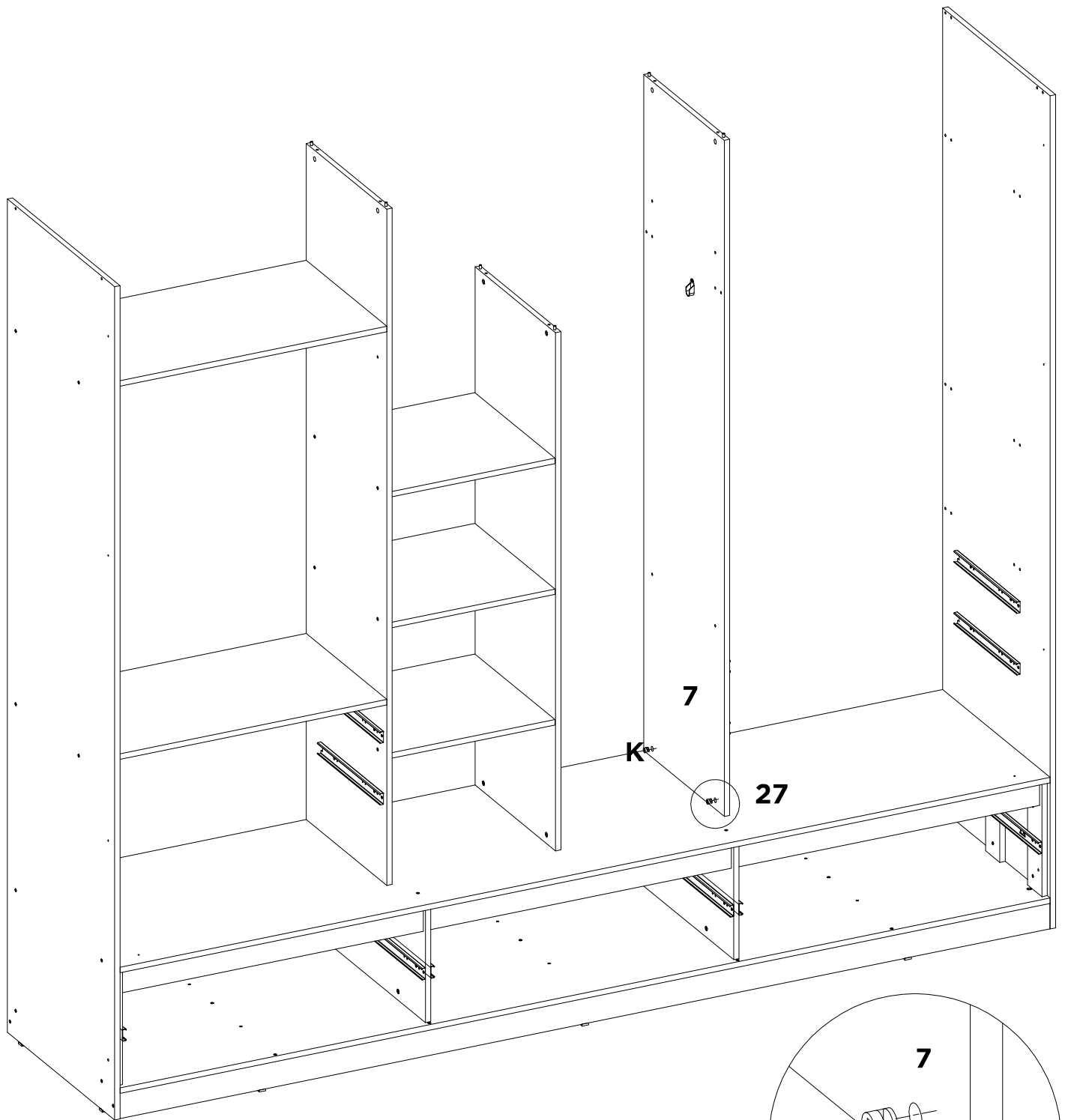

<b>K</b>	-	-	-	-	-	-	-	-
<b>X2</b>	-	-	-	-	-	-	-	-

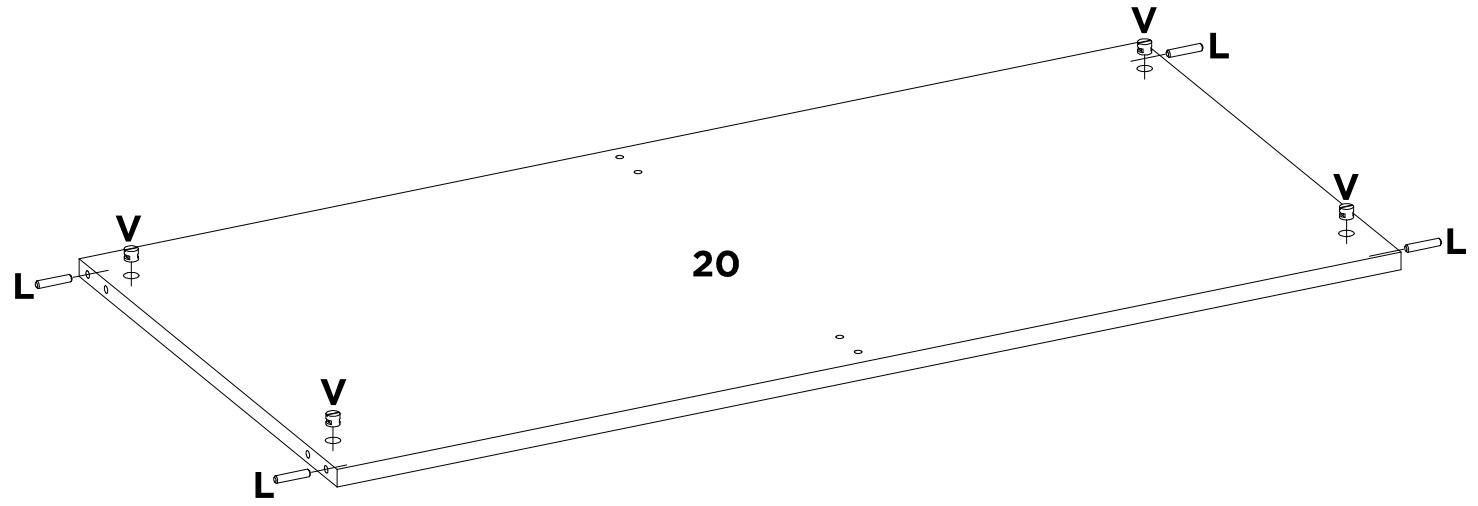

L	V	-	-	-	-	-	-
X4	X4	-	-	-	-	-	-

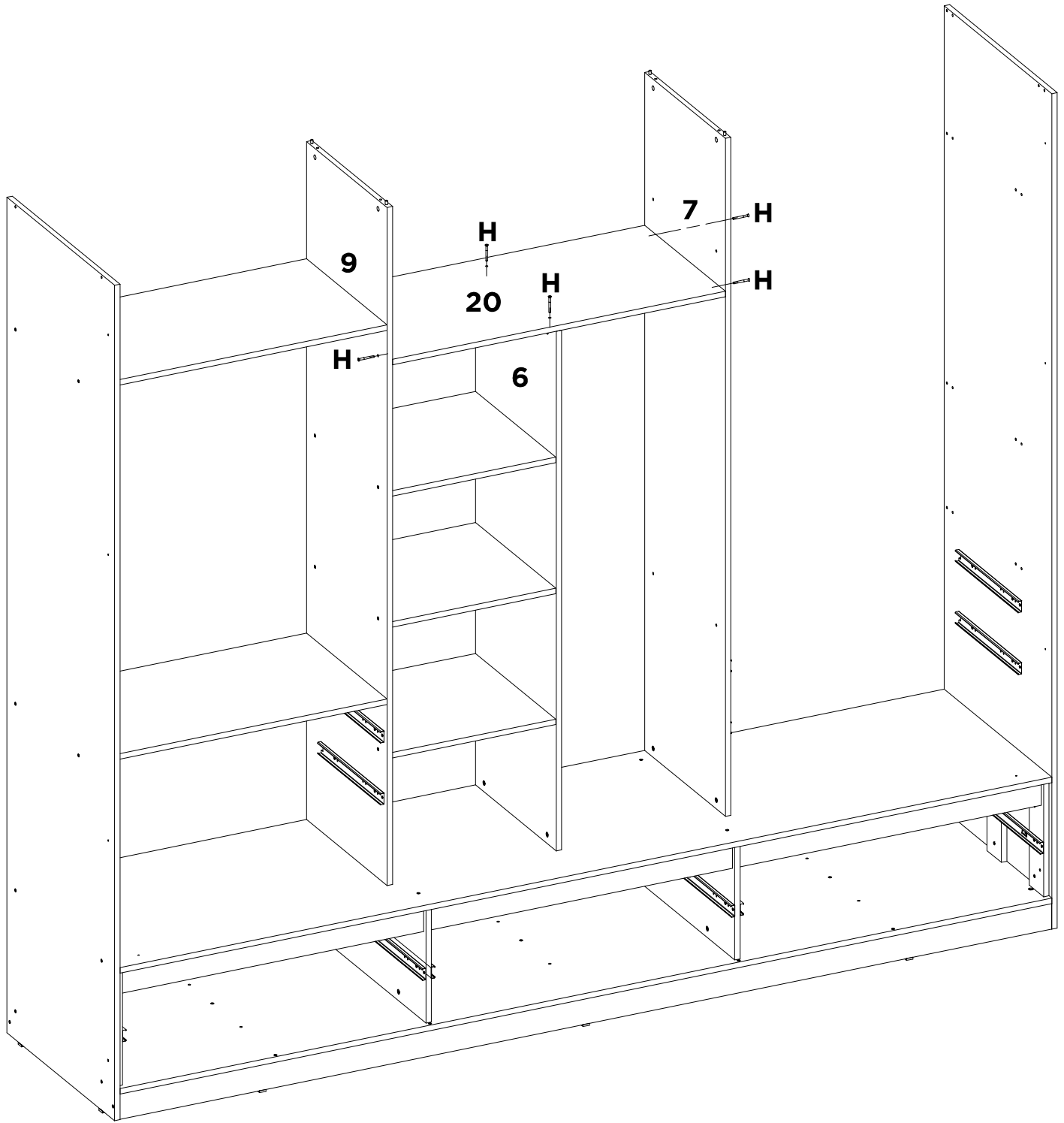

H	-	-	-	-	-	-	-
X6	-	-	-	-	-	-	-



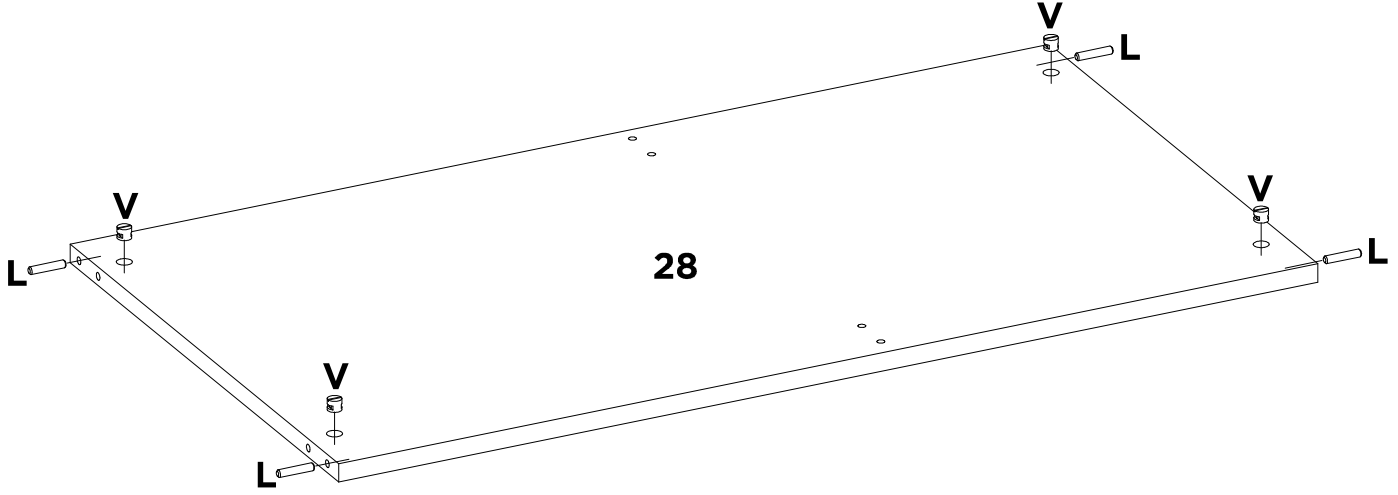

L	V	-	-	-	-	-	-
X4	X4	-	-	-	-	-	-

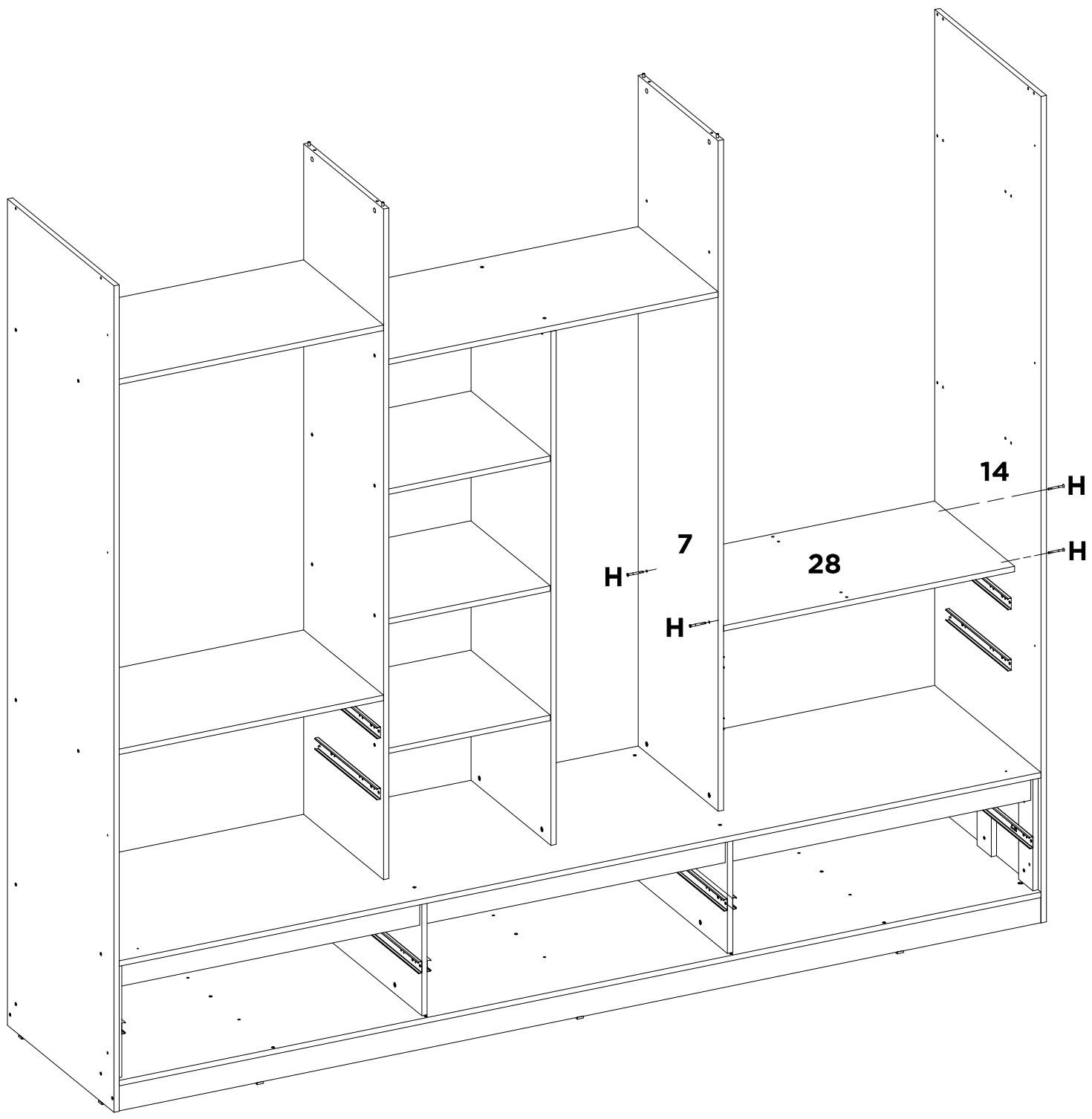

<b>H</b>	-	-	-	-	-	-	-
<b>X4</b>	-	-	-	-	-	-	-

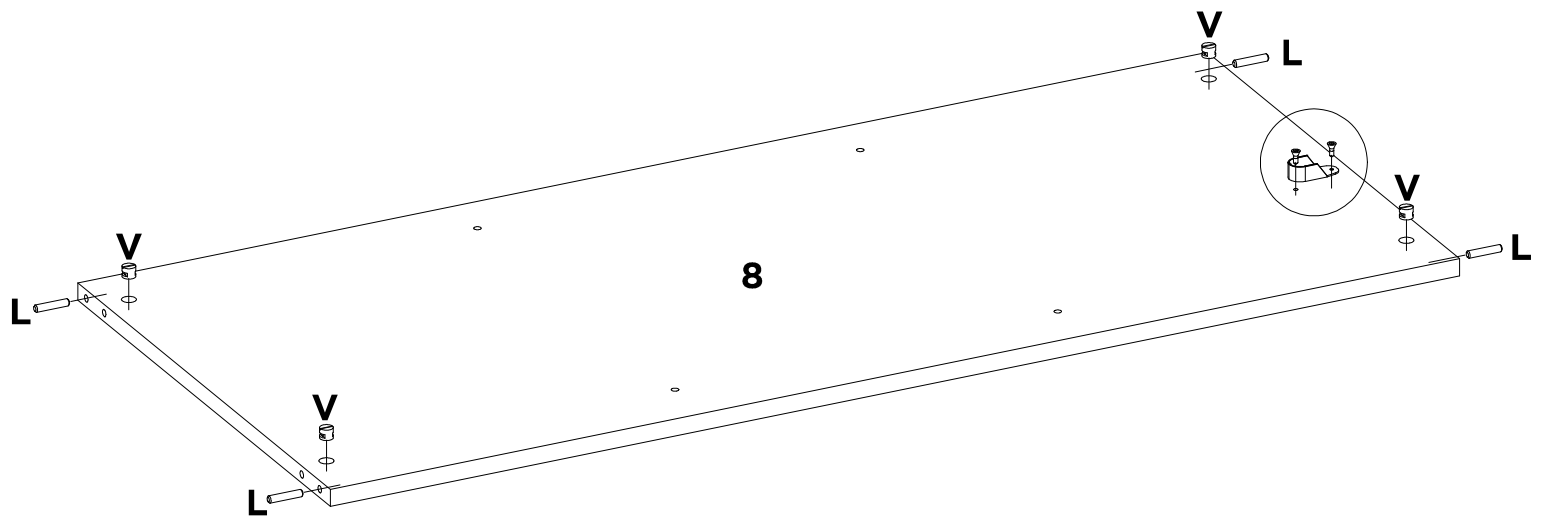
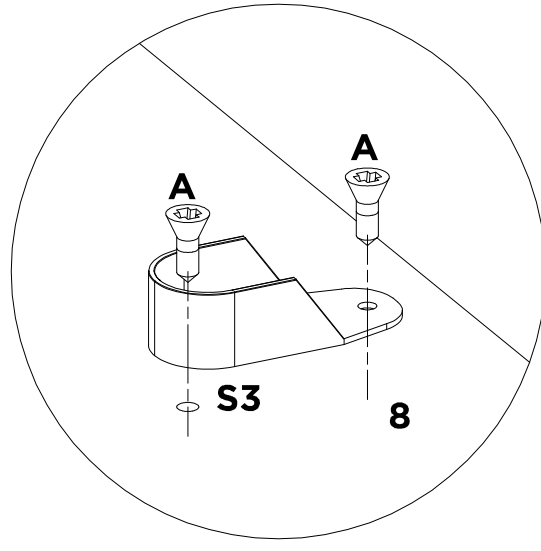

<b>A</b>	<b>L</b>	<b>V</b>	<b>S3</b>	-	-	-	-
<b>X2</b>	<b>X4</b>	<b>X4</b>	<b>X1</b>	-	-	-	-

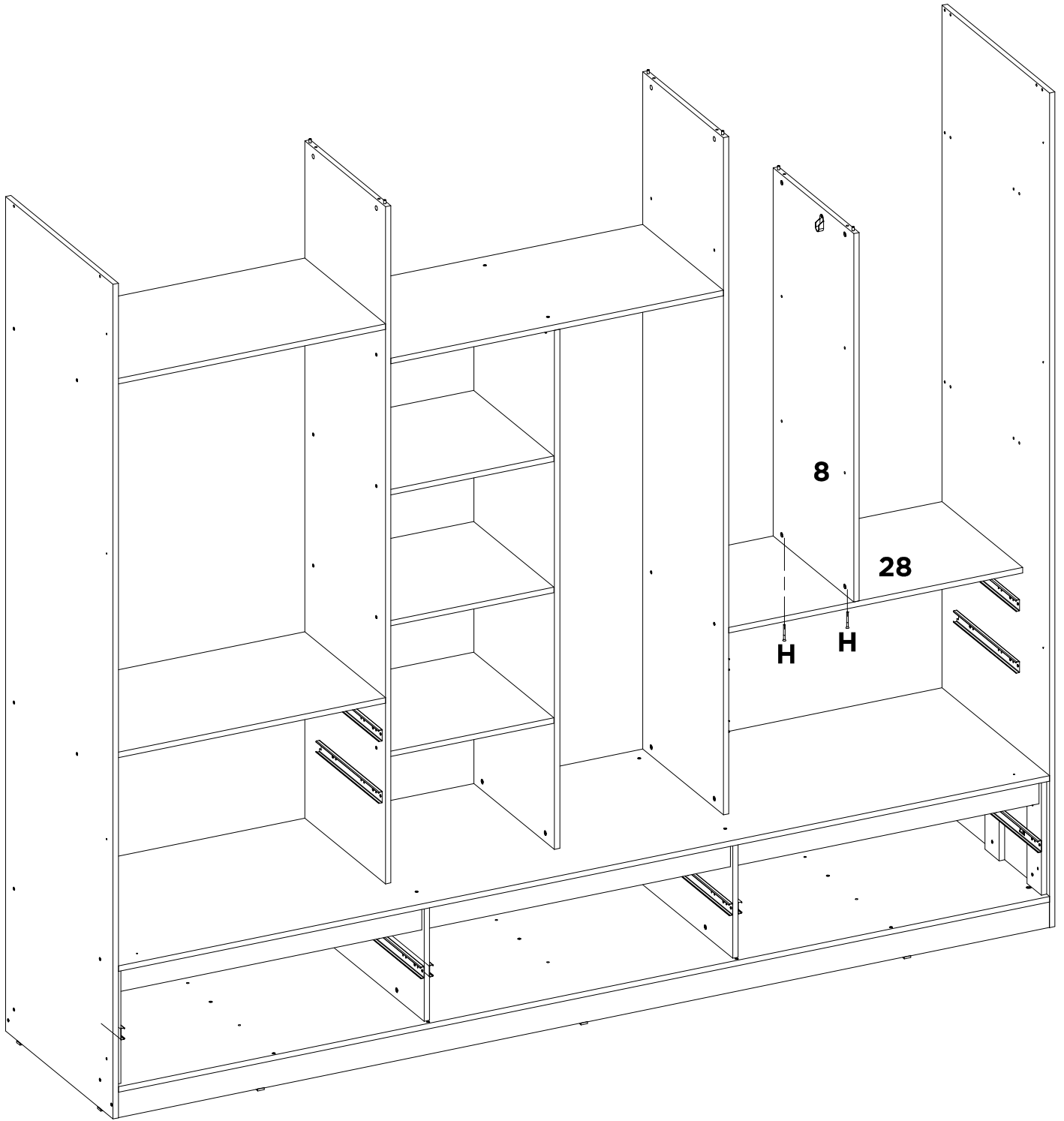

H	-	-	-	-	-	-	-
X2	-	-	-	-	-	-	-

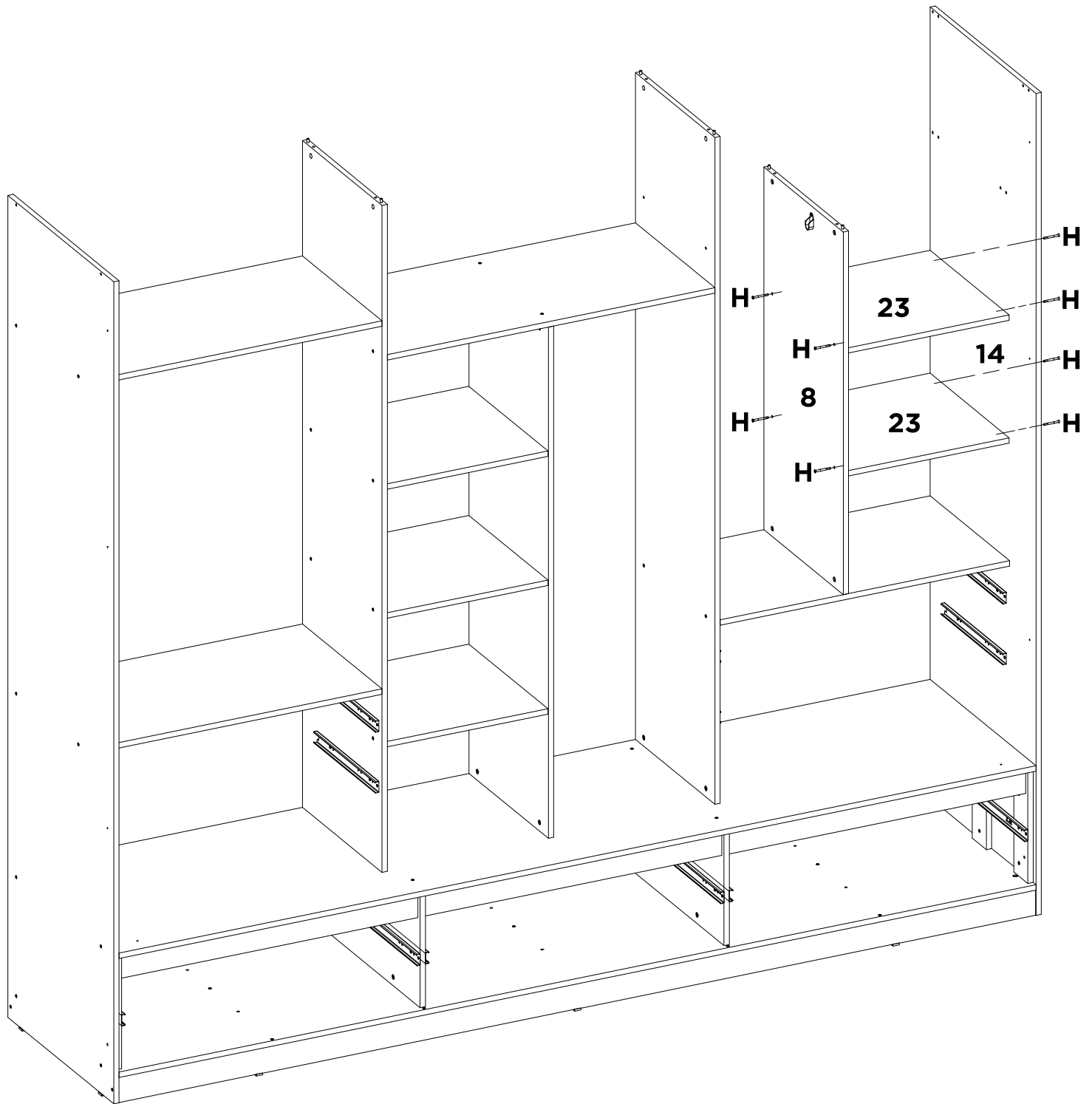

<b>H</b>	-	-	-	-	-	-	-
<b>X8</b>	-	-	-	-	-	-	-

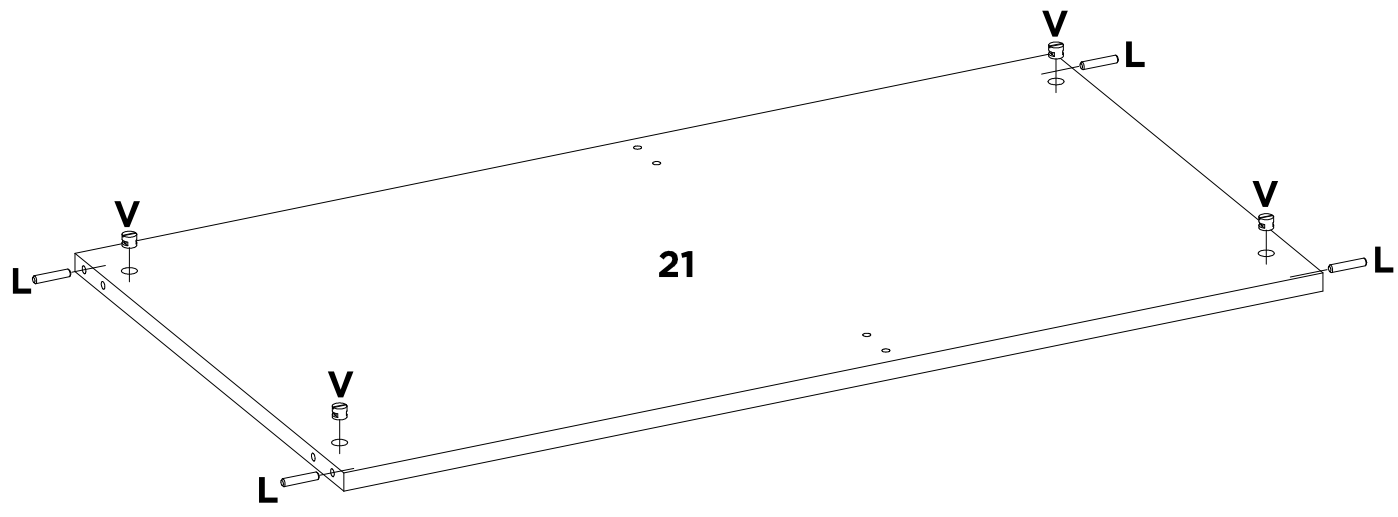

L	V	-	-	-	-	-	-
X4	X4	-	-	-	-	-	-

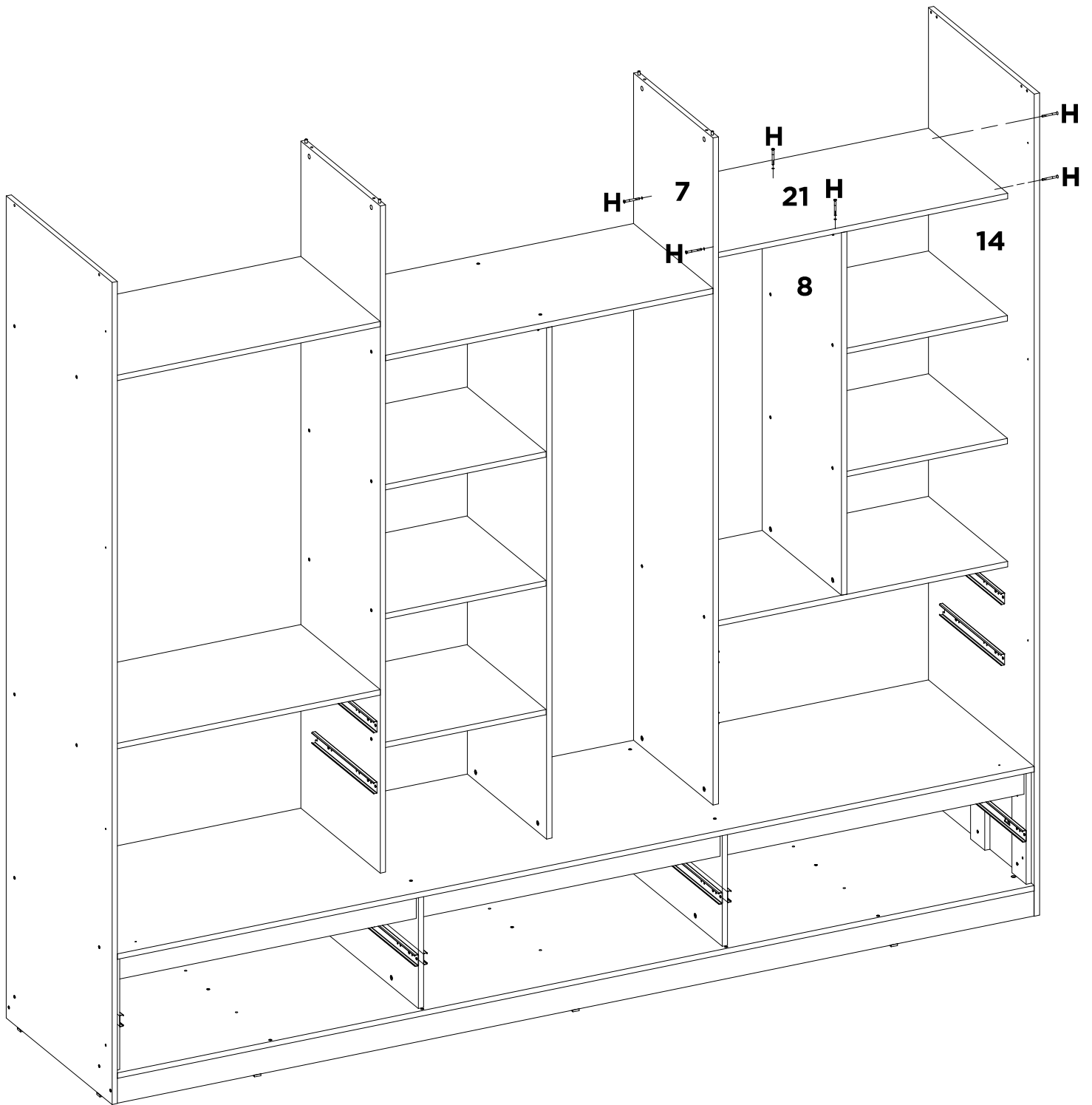

<b>H</b>	-	-	-	-	-	-	-	-
<b>X6</b>	-	-	-	-	-	-	-	-

# 36

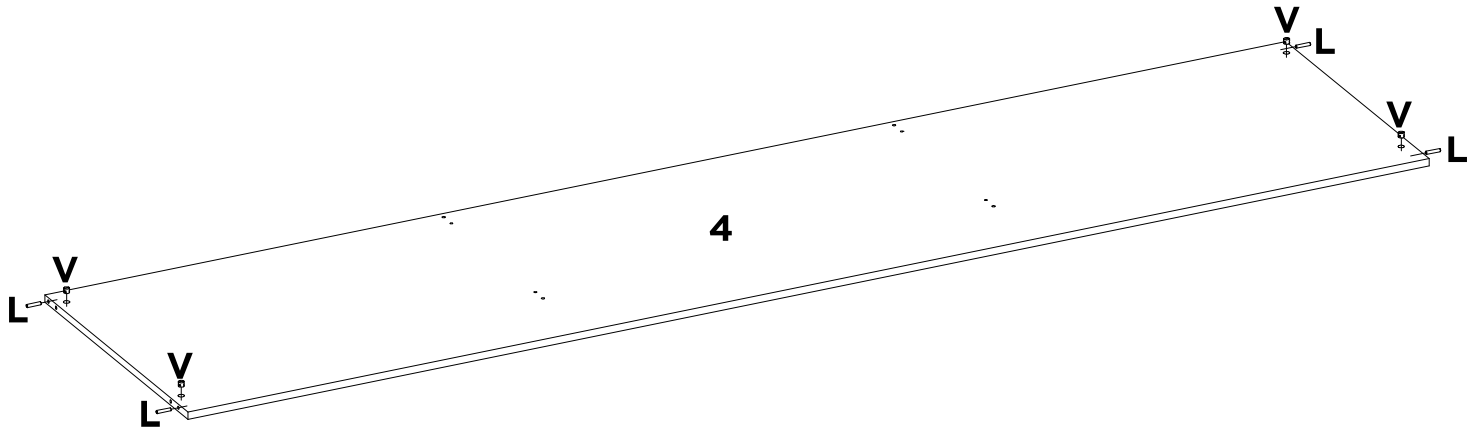

L	V	-	-	-	-	-	-
X4	X4	-	-	-	-	-	-

# 36A

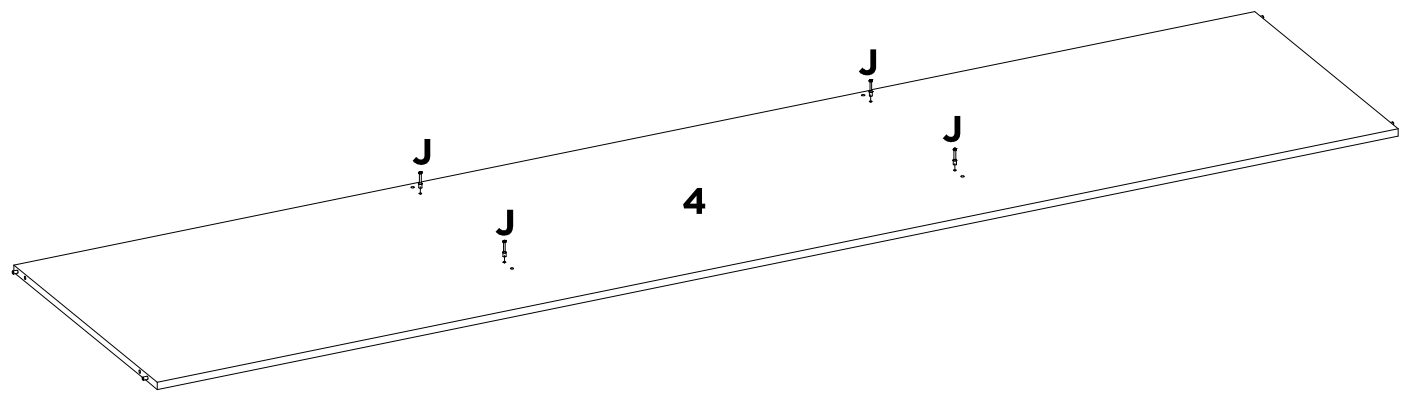

J	-	-	-	-	-	-	-
X4	-	-	-	-	-	-	-



# 37

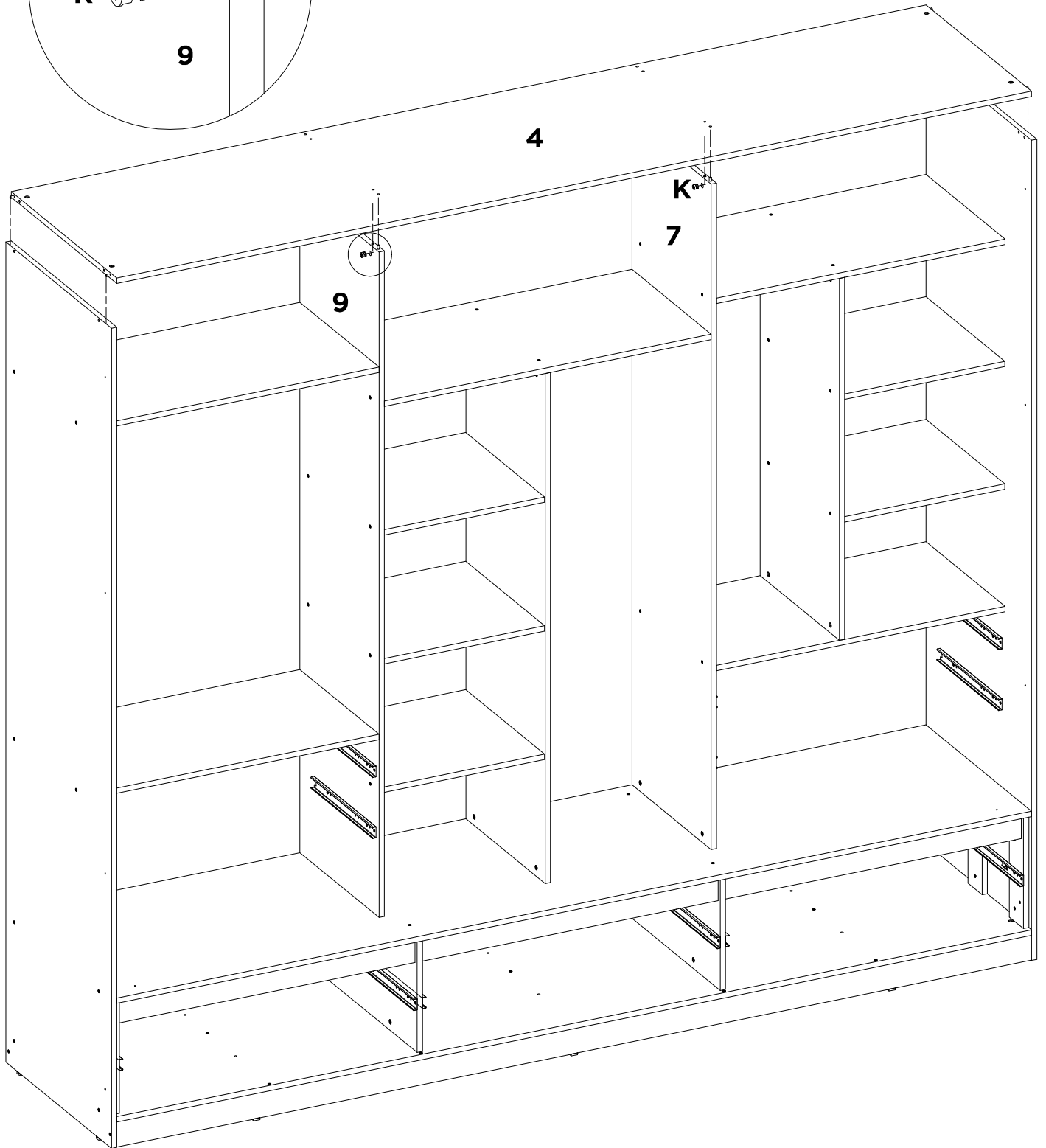
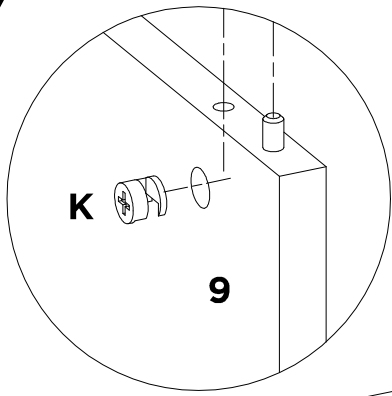

<b>K</b>	-	-	-	-	-	-	-	-
<b>X4</b>	-	-	-	-	-	-	-	-

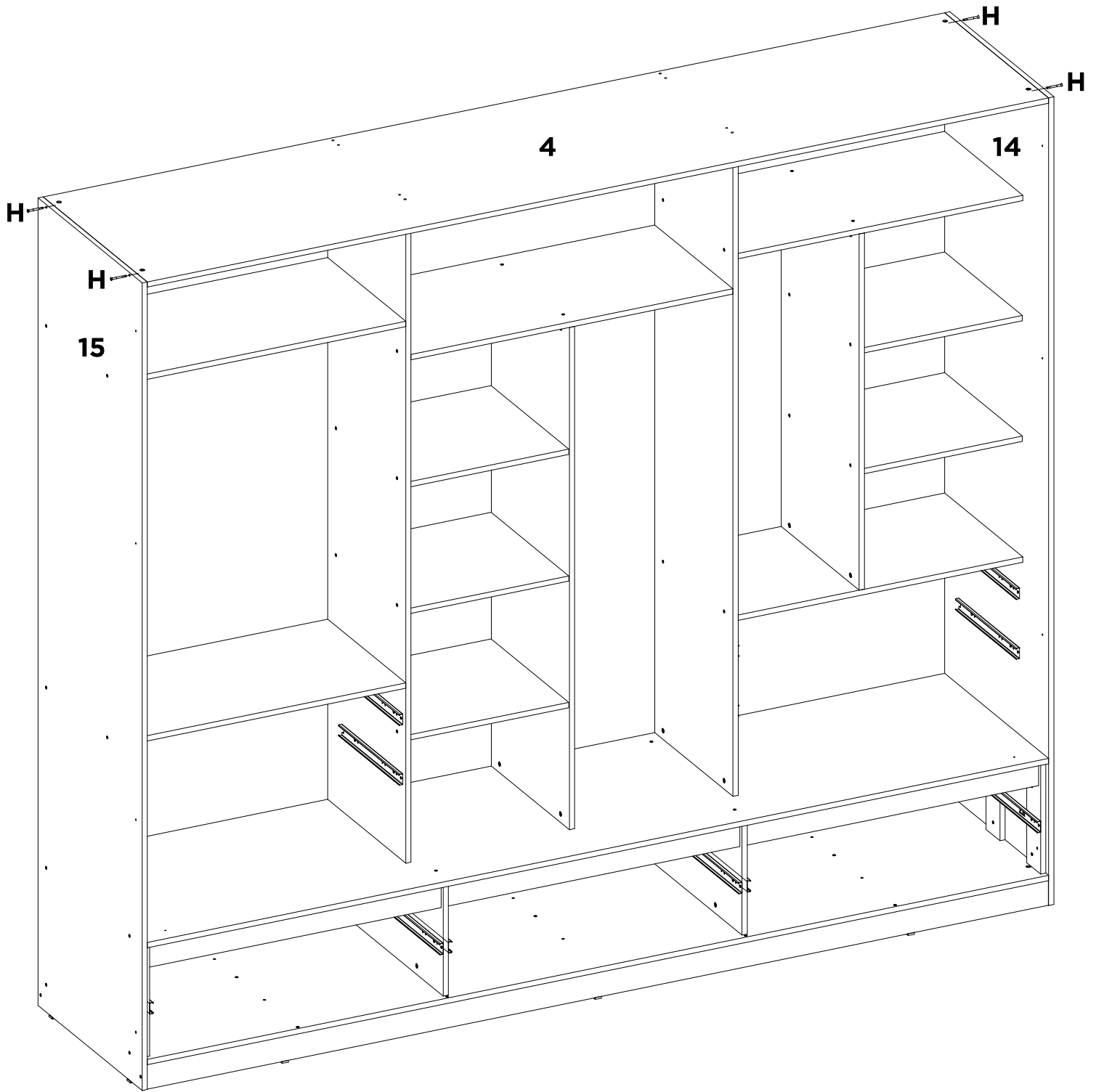

H	-	-	-	-	-	-	-	-
X4	-	-	-	-	-	-	-	-

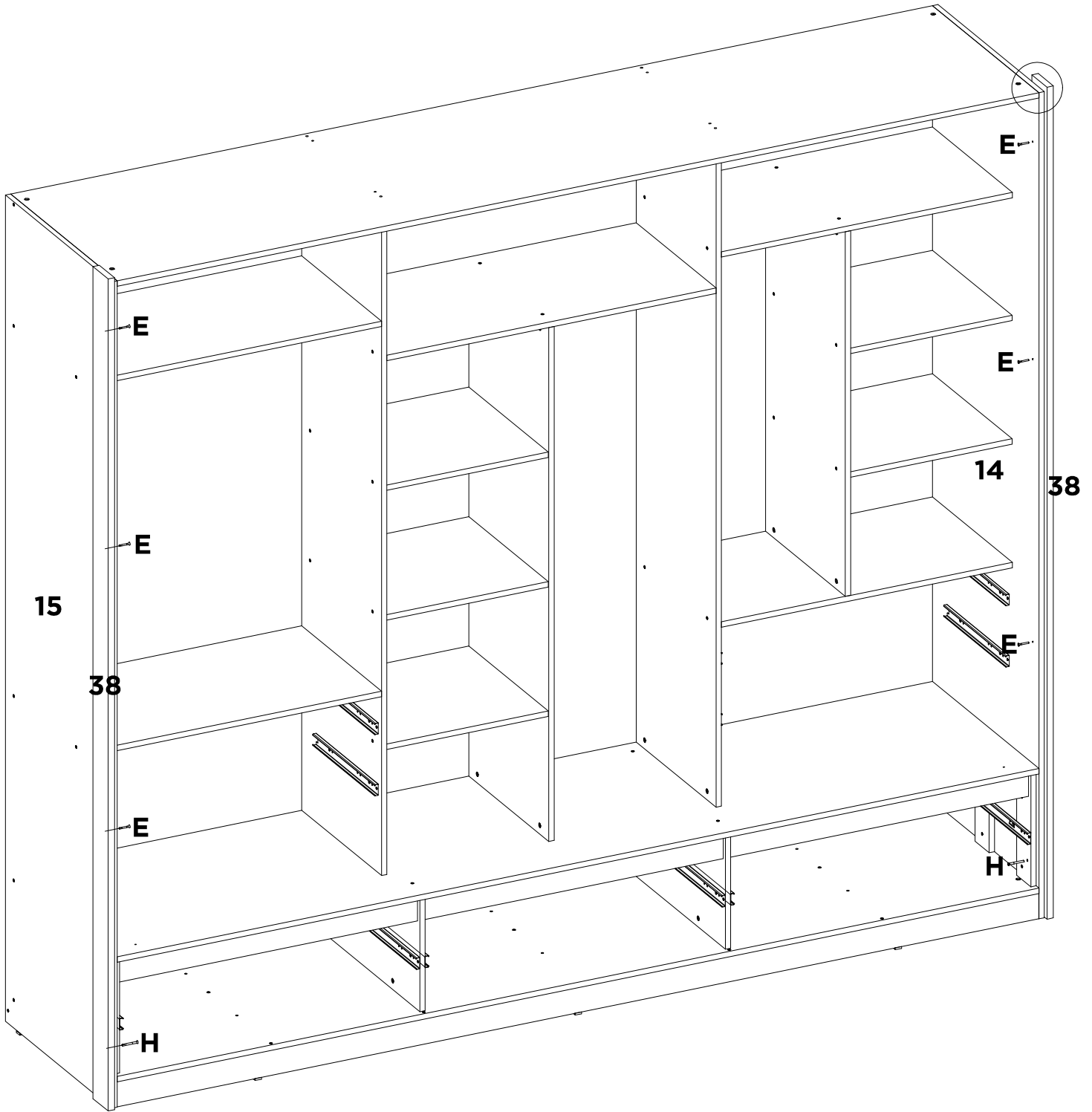
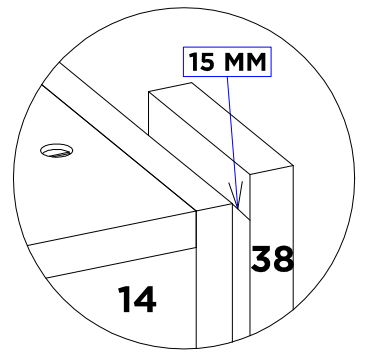

<b>E</b>	<b>H</b>	-	-	-	-	-	-
<b>X6</b>	<b>X2</b>	-	-	-	-	-	-

# 40

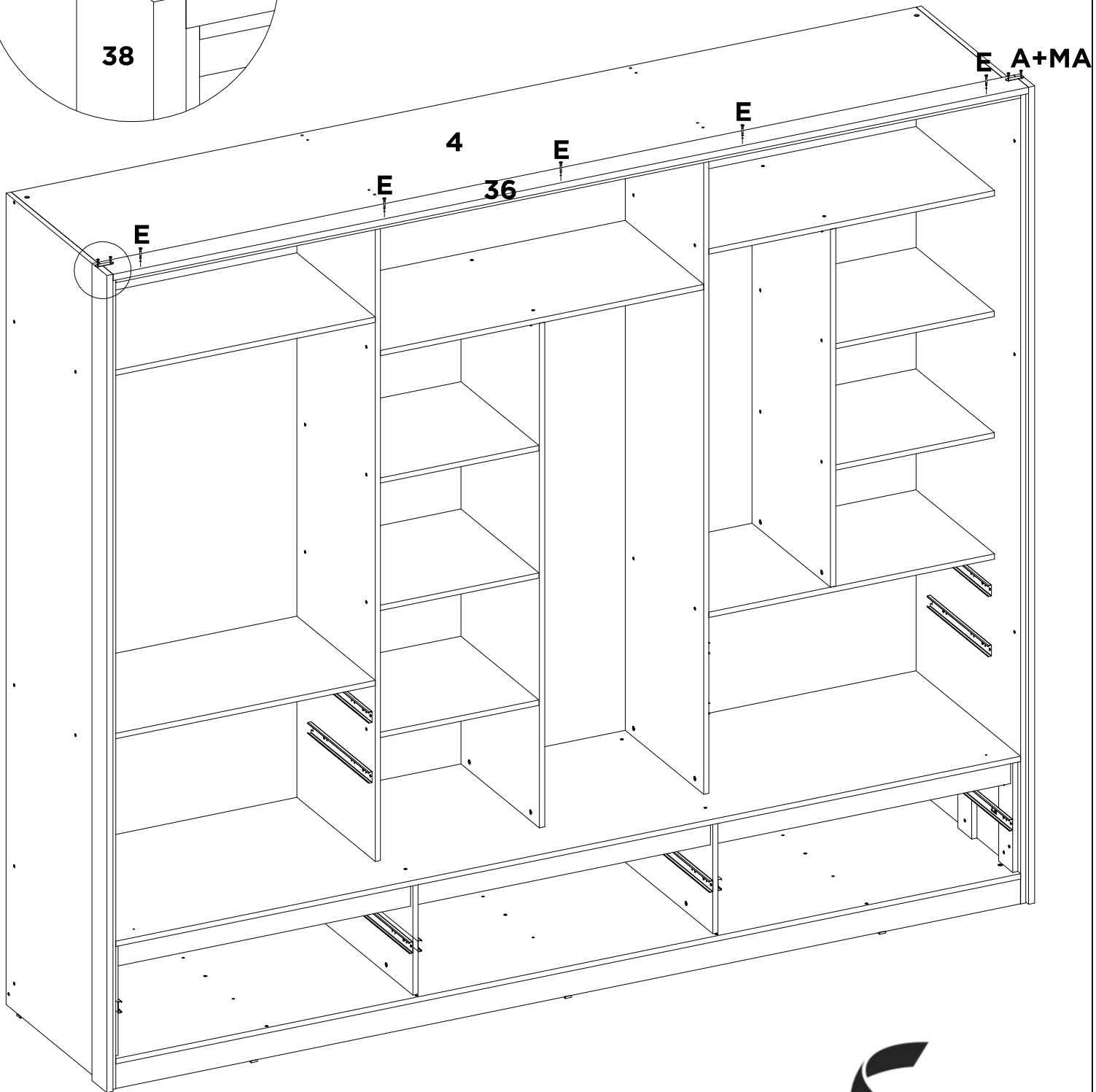
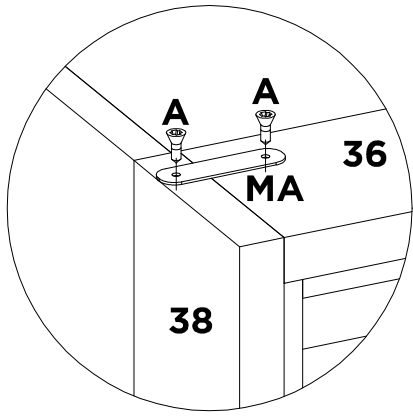

<b>A</b>	<b>E</b>	<b>MA</b>	-	-	-	-	-
<b>X4</b>	<b>X5</b>	<b>X2</b>	-	-	-	-	-

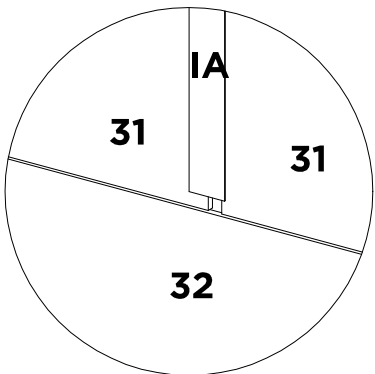
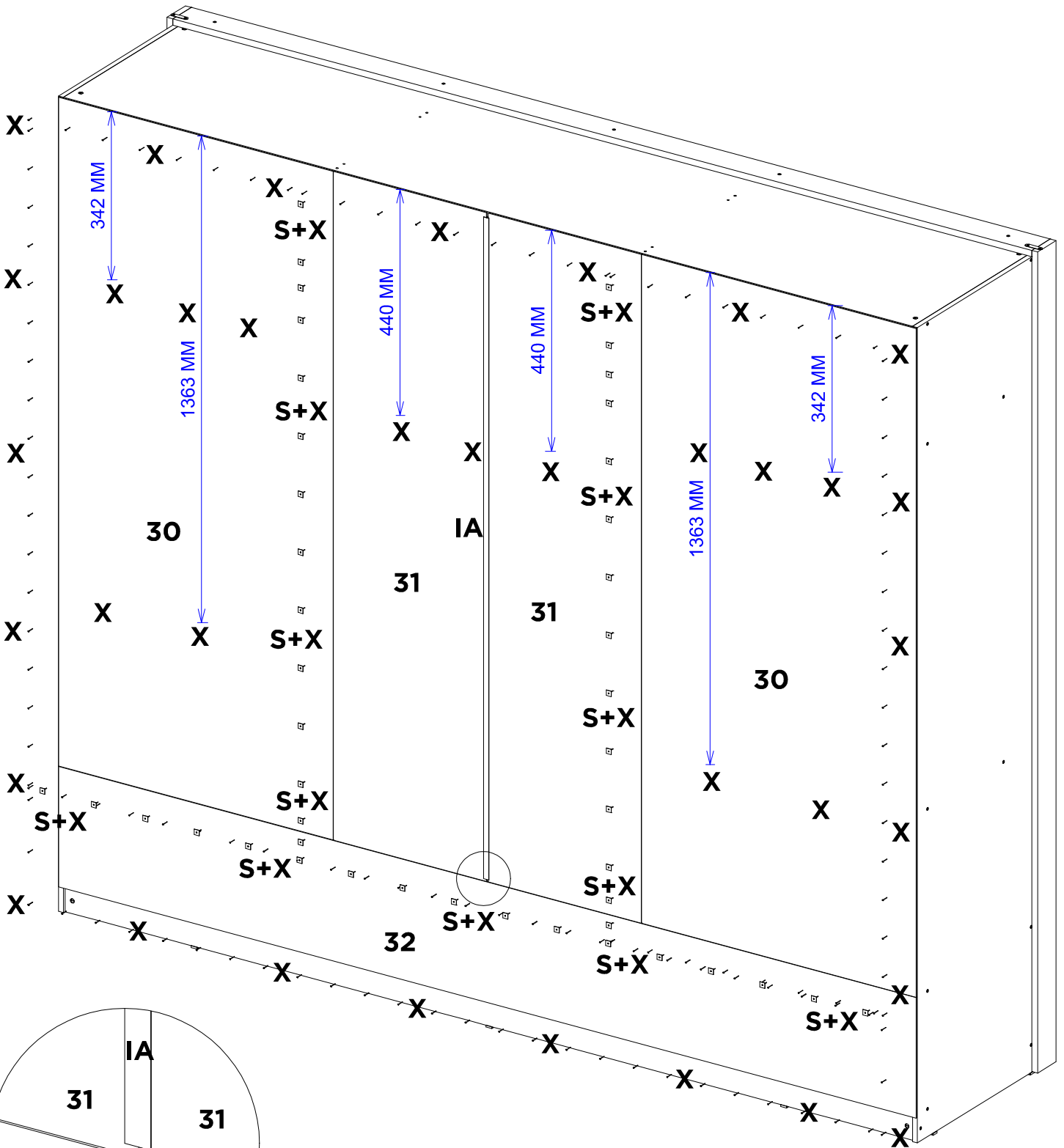

IA	S	X	-	-	-	-	-
X1	X45	X180	-	-	-	-	-

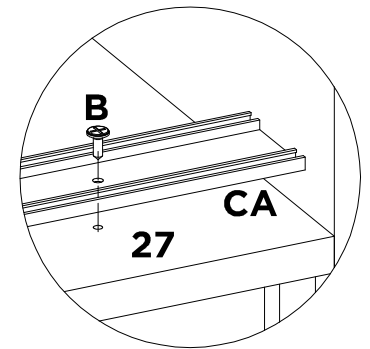
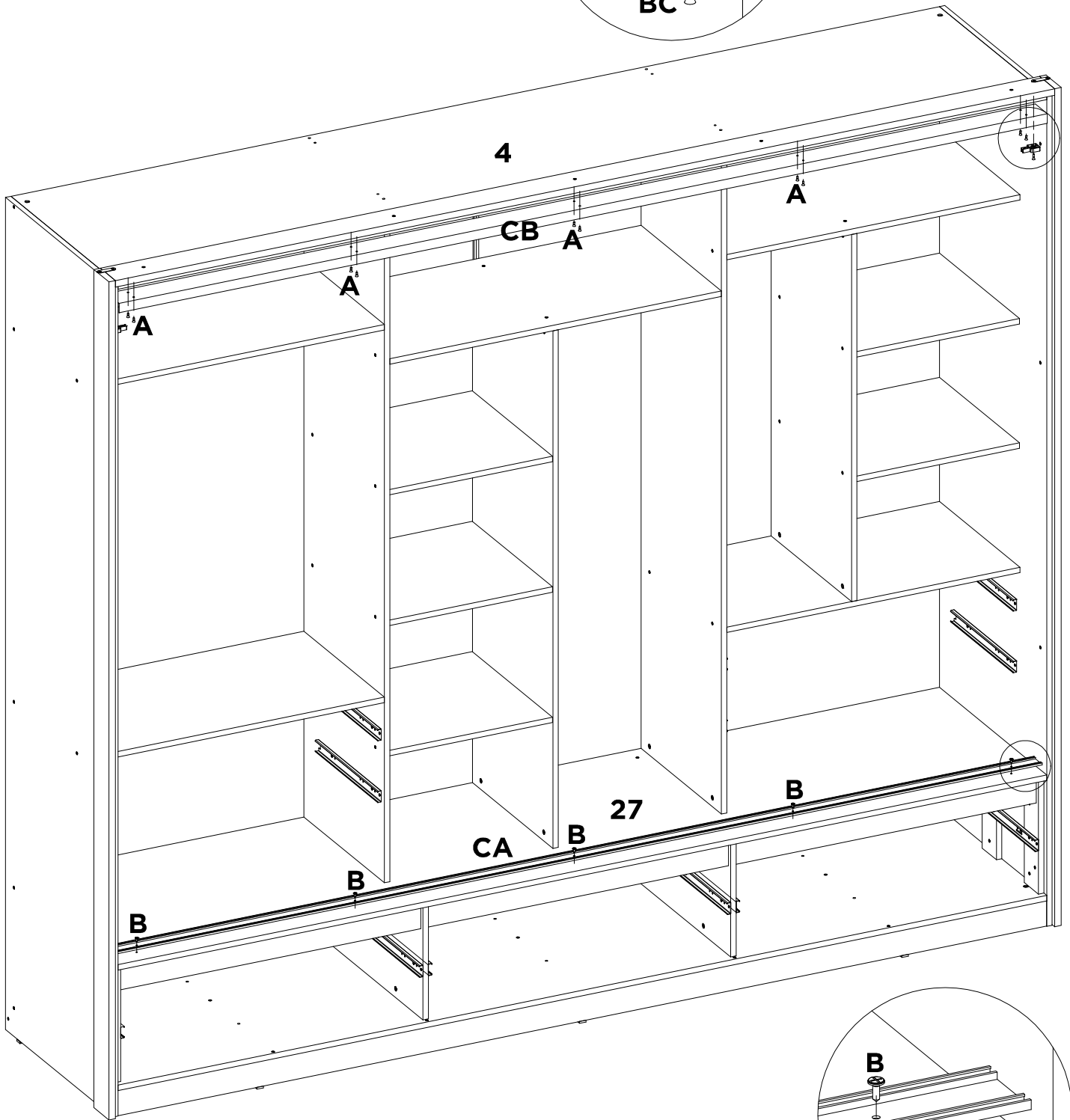
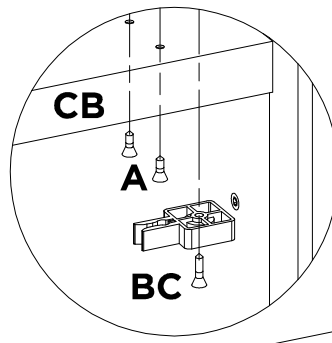

A	B	BC	CA	CB	-	-	-
X10	X5	X2	X1	X1	-	-	-

# 43

4x

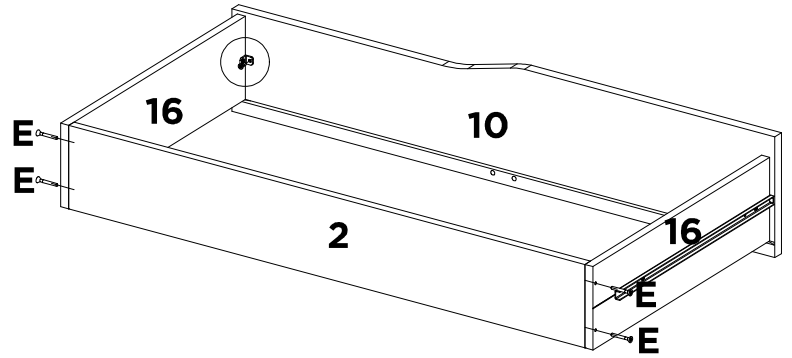
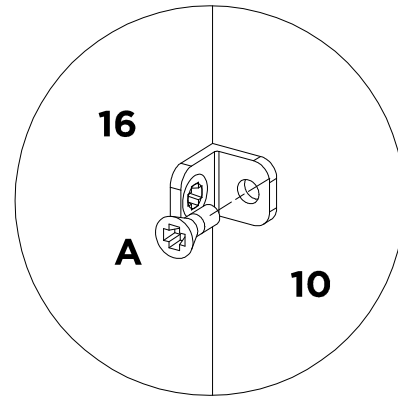
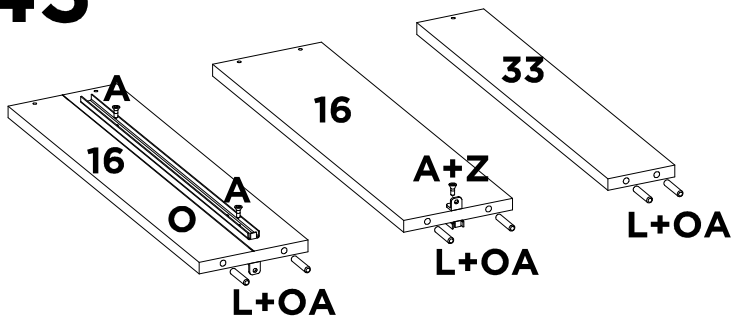

<b>A</b>	<b>E</b>	<b>L</b>	<b>O</b>	<b>OA</b>	<b>Z</b>	-	-
<b>X32</b>	<b>X16</b>	<b>X24</b>	<b>X8</b>	<b>X2</b>	<b>X8</b>	-	-

# 43A

4x

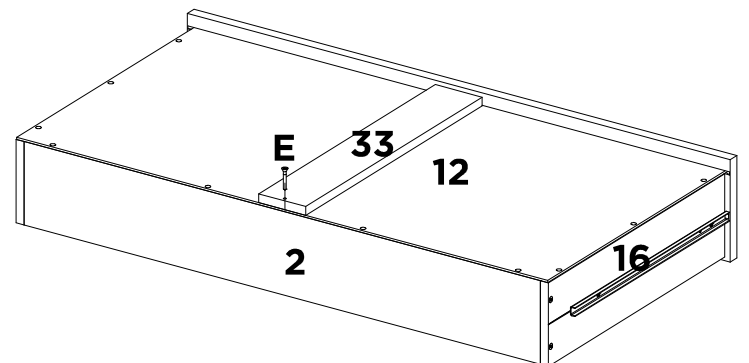
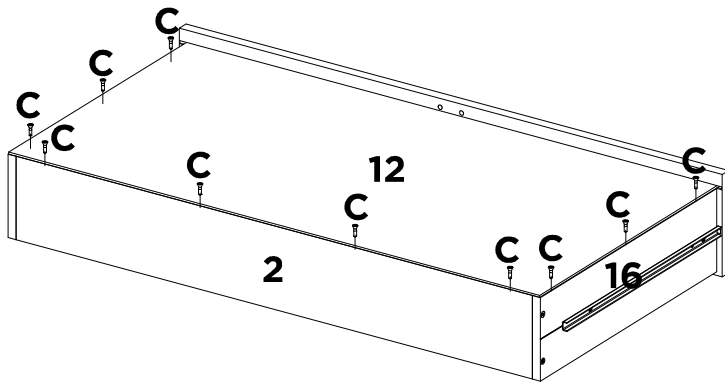

<b>C</b>	<b>E</b>	-	-	-	-	-	-
<b>X40</b>	<b>X4</b>	-	-	-	-	-	-

# 44

3x

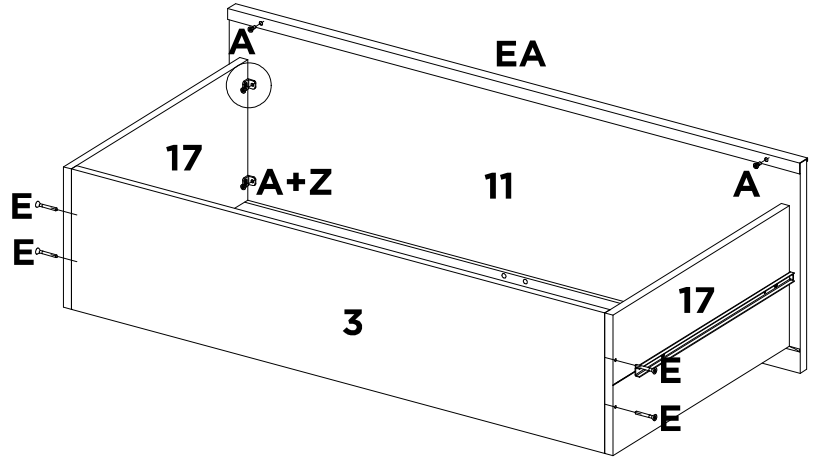
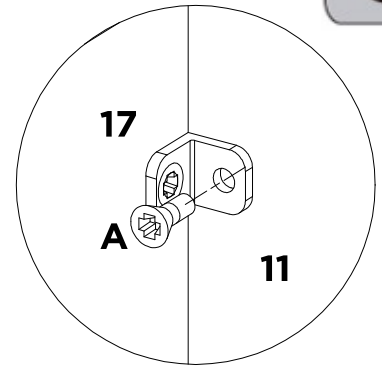
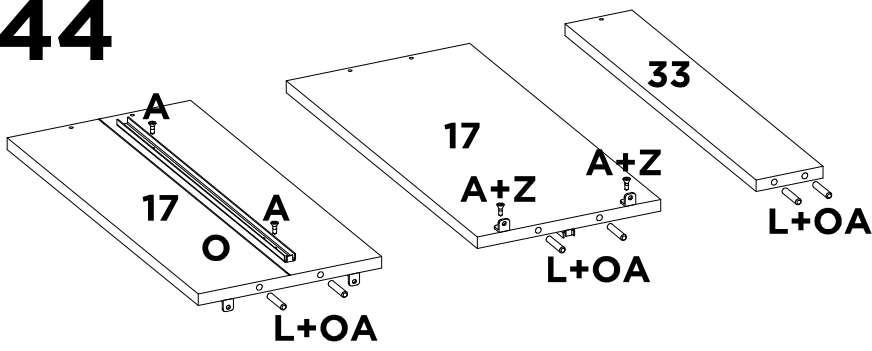

A	E	EA	L	O	OA	Z	-
X42	X12	X3	X18	X6	X1	X12	-

# 44A

3x

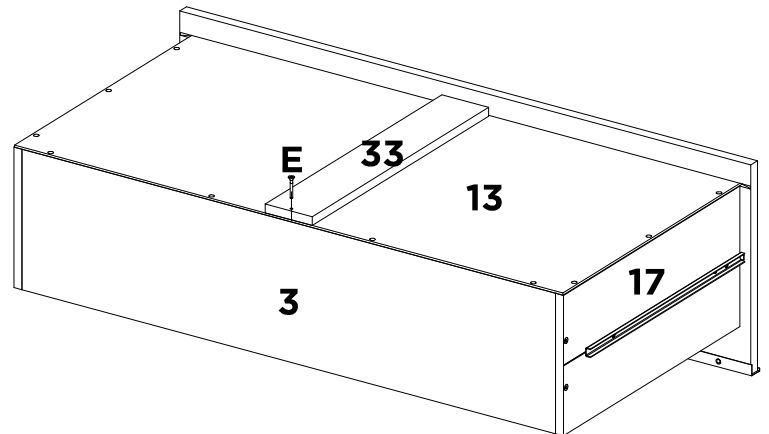
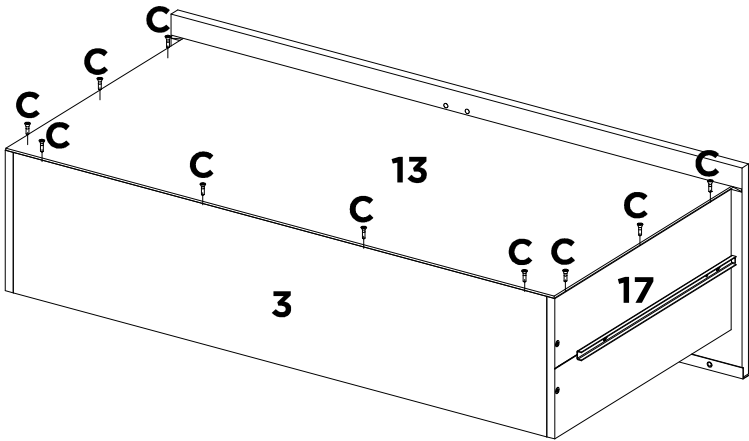

C	E	-	-	-	-	-	-
X30	X3	-	-	-	-	-	-



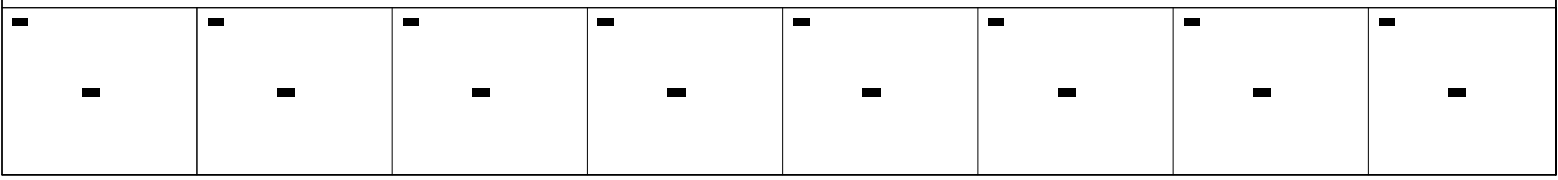
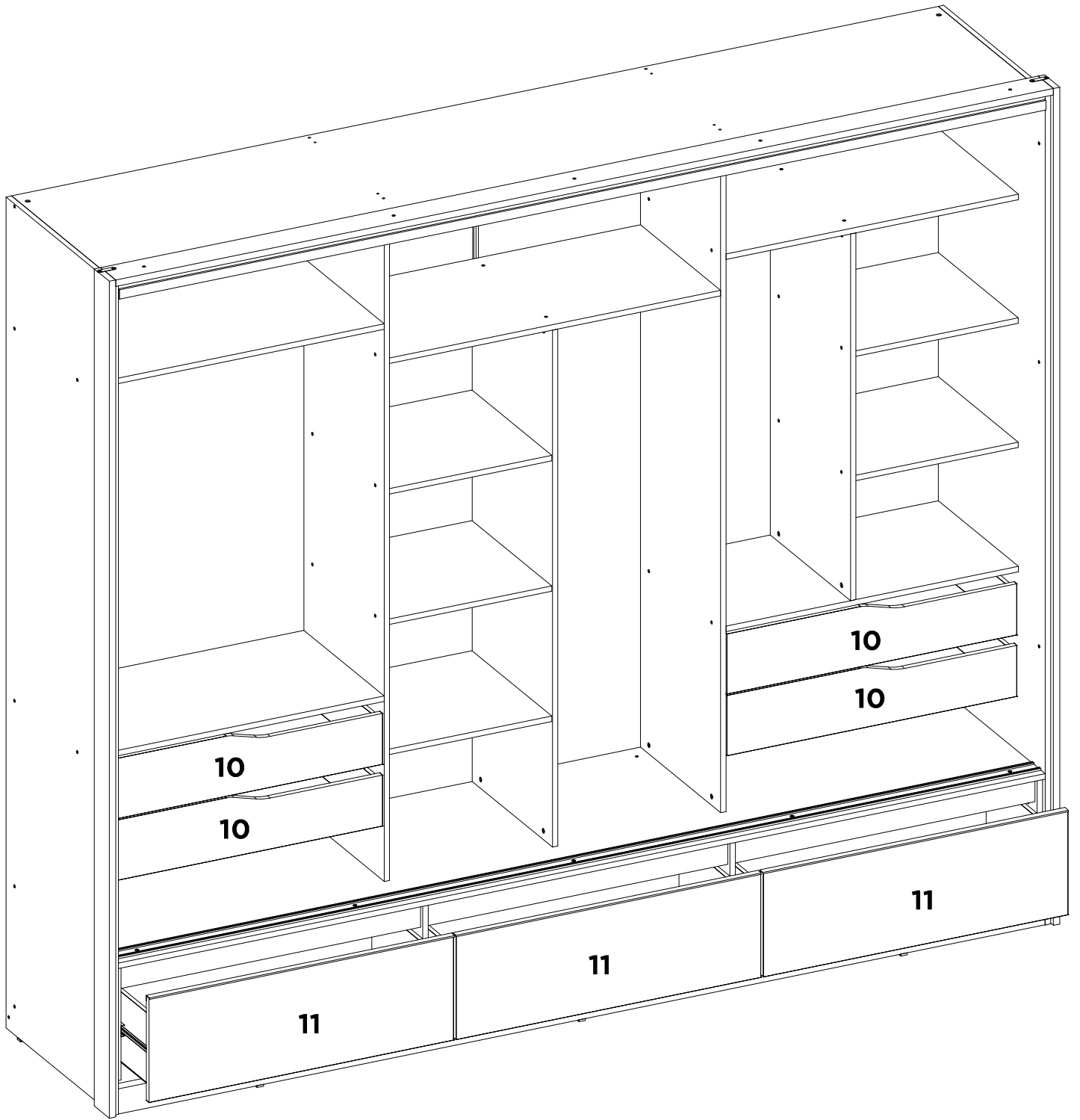

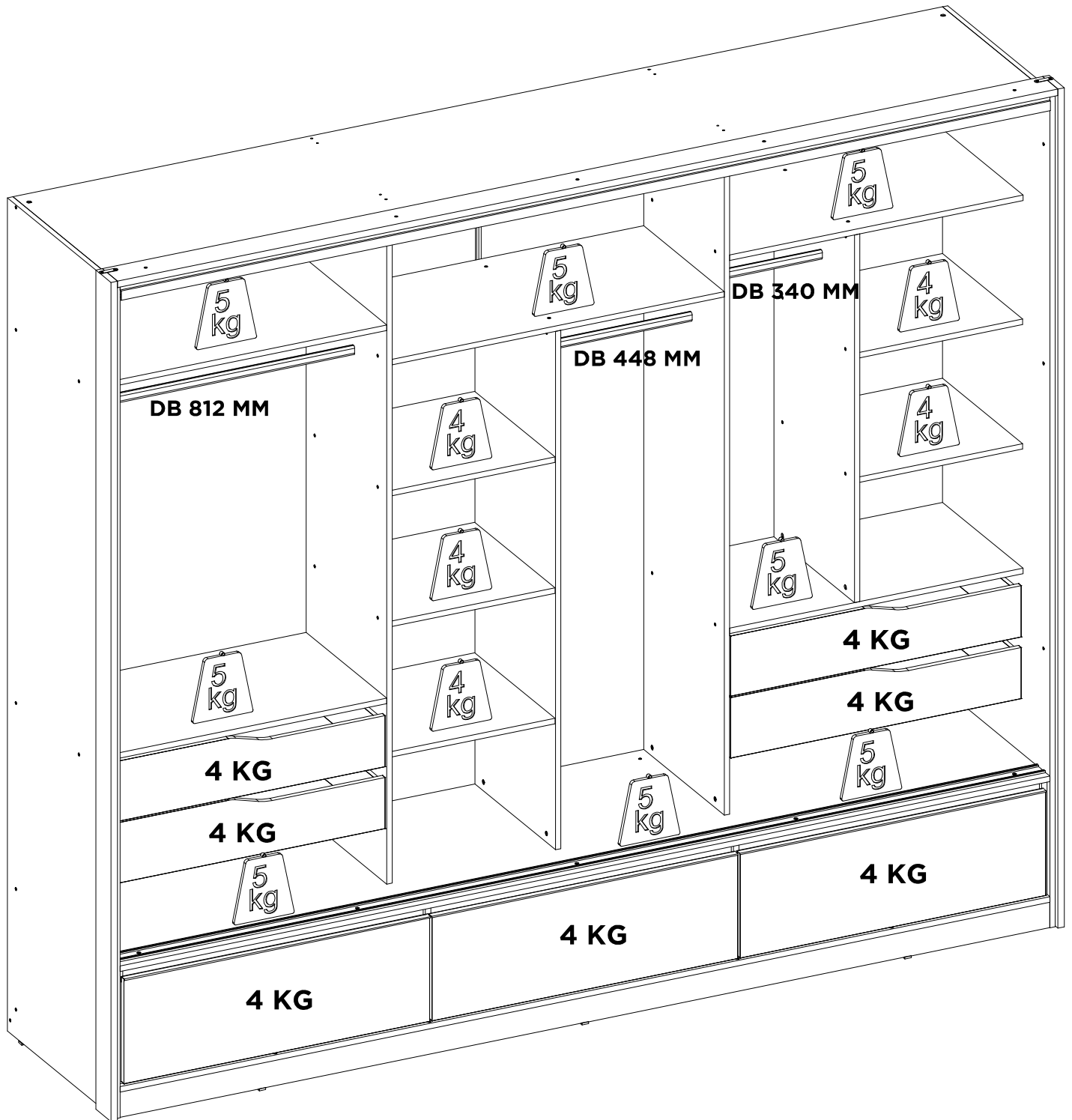

DB 340 MM	DB 448 MM	DB 812 MM	-	-	-
X1	X1	X1	-	-	-

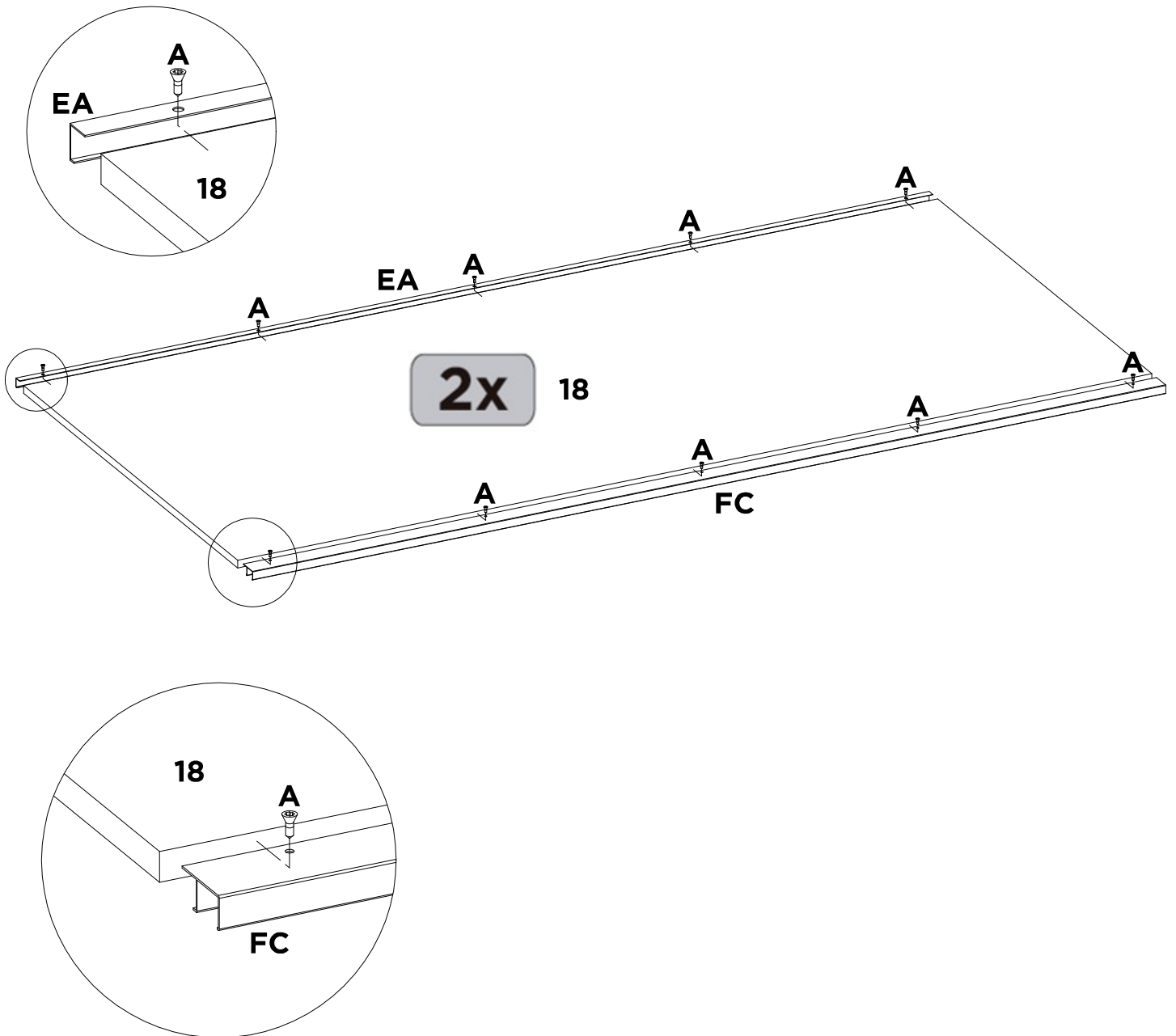

<b>A</b>	<b>EA</b>	<b>FC</b>	-	-	-	-	-
<b>X20</b>	<b>X2</b>	<b>X2</b>	-	-	-	-	-

# 48

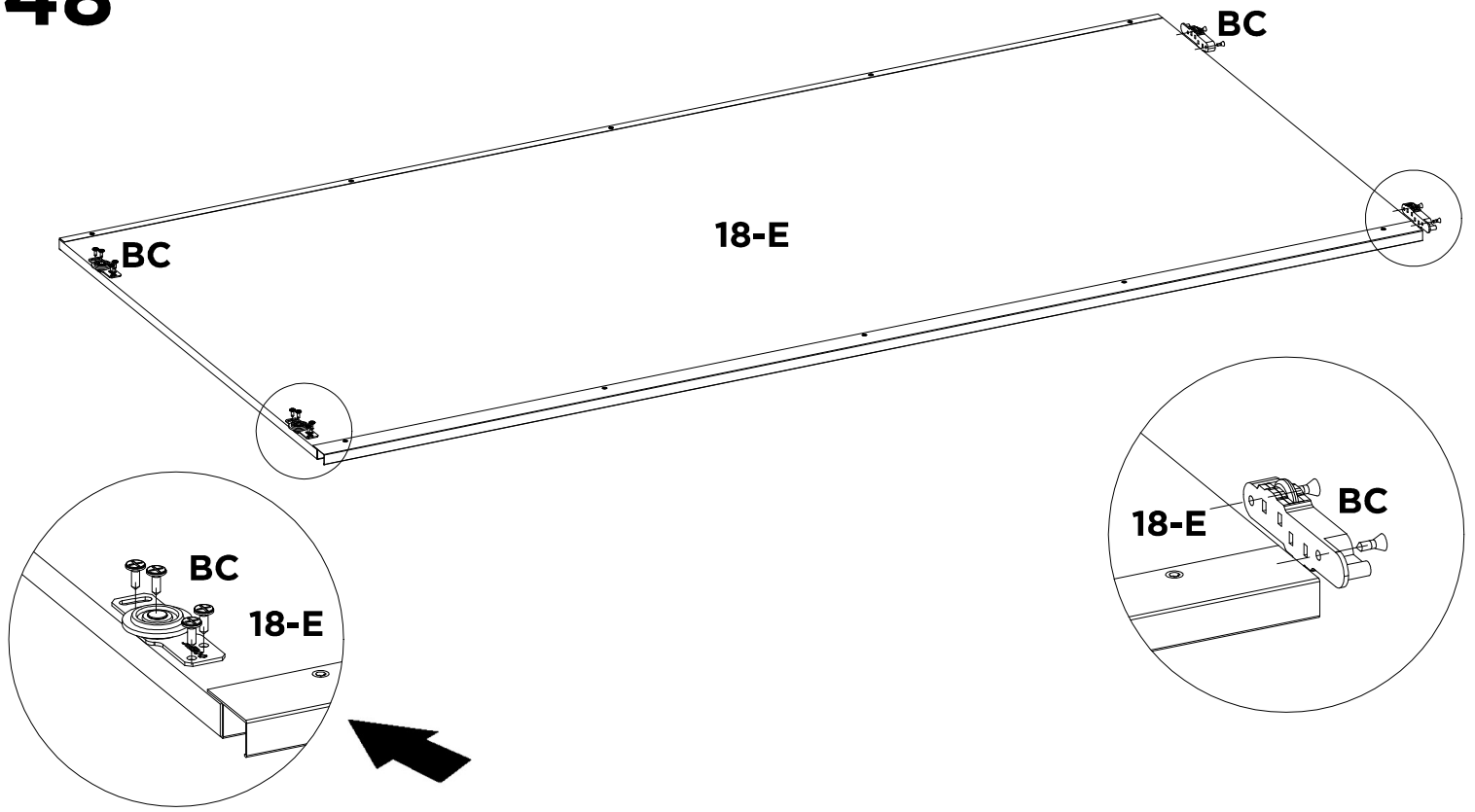

BC	-	-	-	-	-	-	-	-
X4	-	-	-	-	-	-	-	-

# 48A

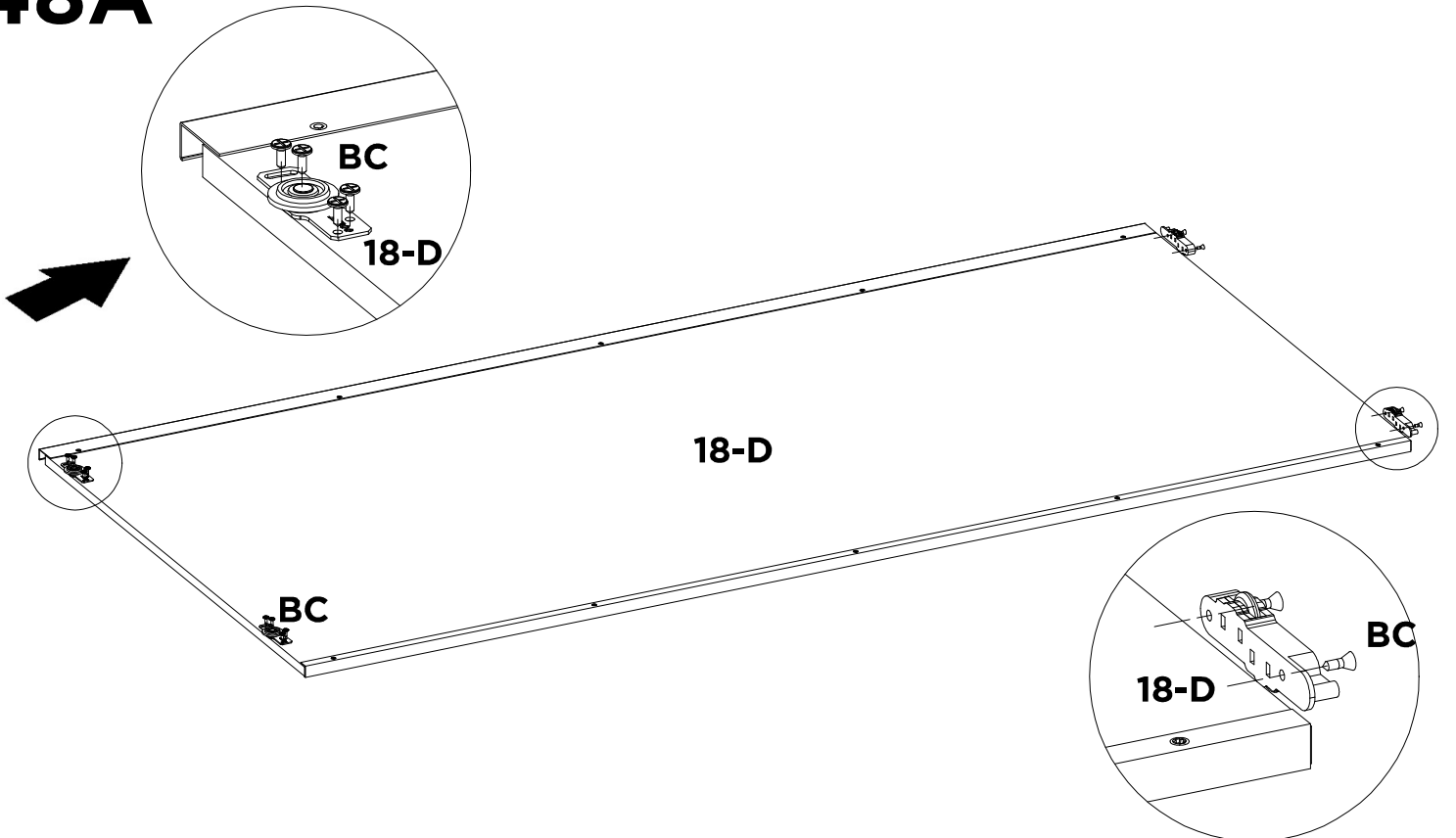

BC	-	-	-	-	-	-	-	-
X4	-	-	-	-	-	-	-	-

# 49

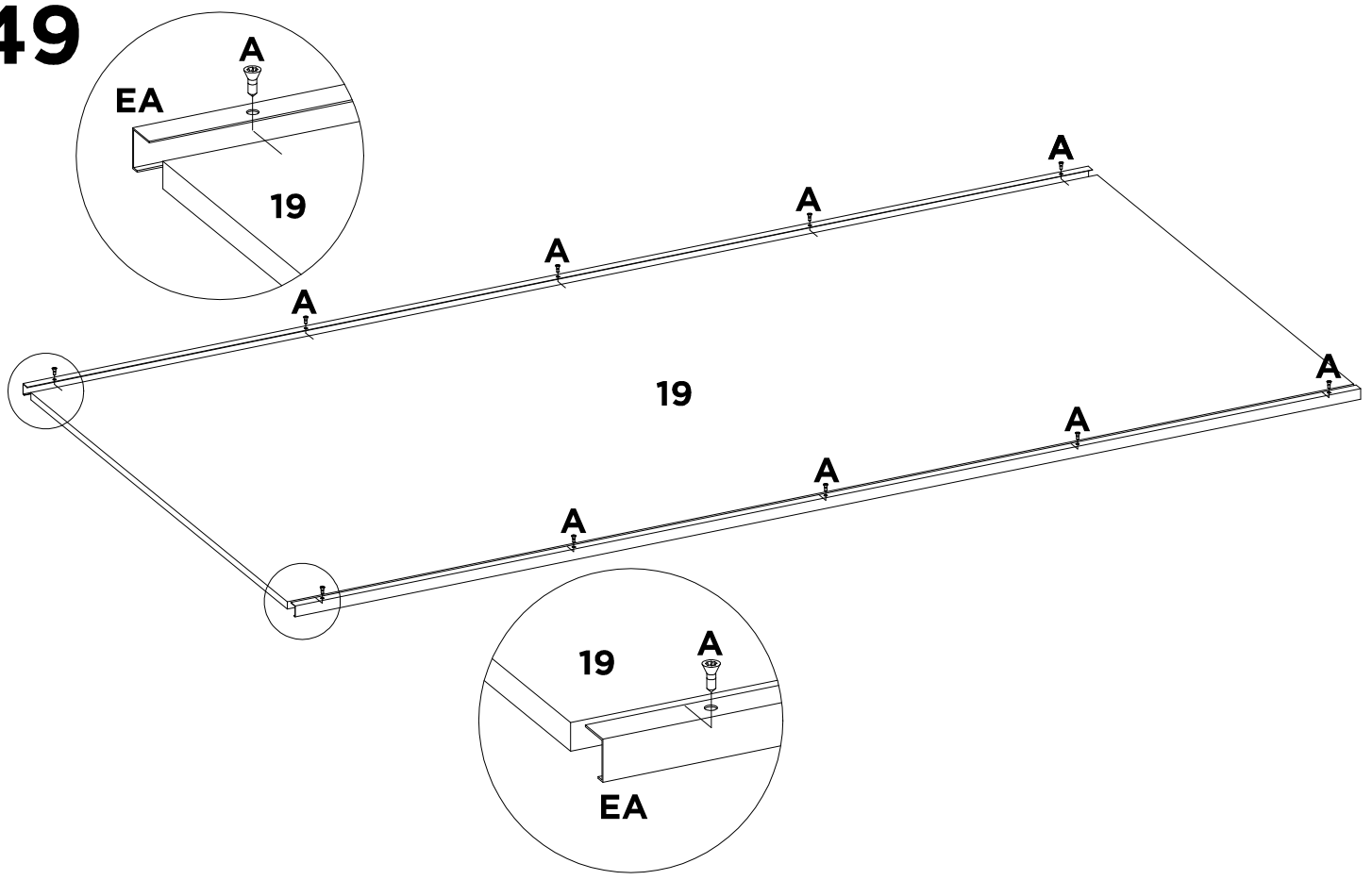

<b>A</b>	<b>EA</b>	-	-	-	-	-	-
<b>X10</b>	<b>X2</b>	-	-	-	-	-	-

# 49A

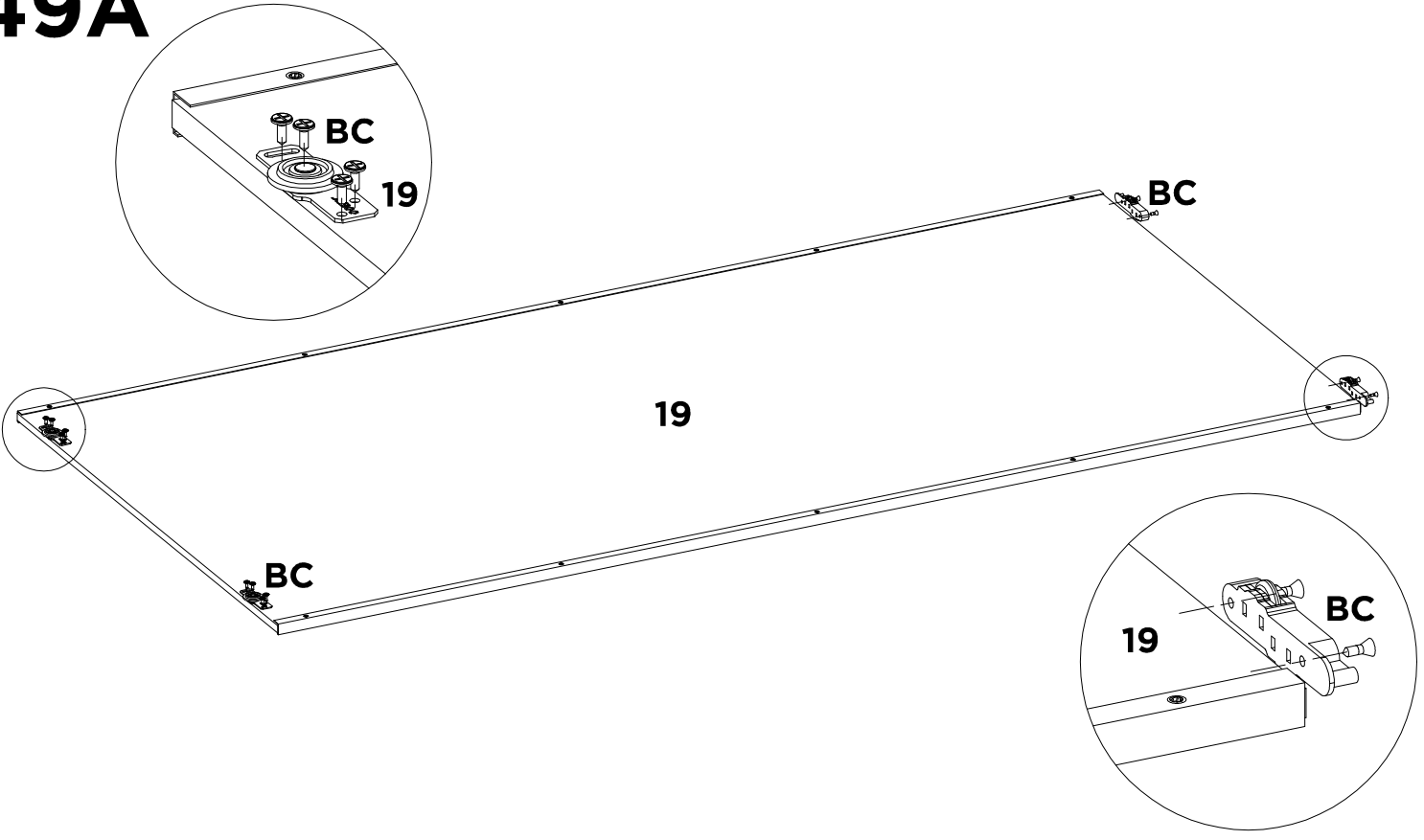

<b>BC</b>	-	-	-	-	-	-	-
<b>X4</b>	-	-	-	-	-	-	-

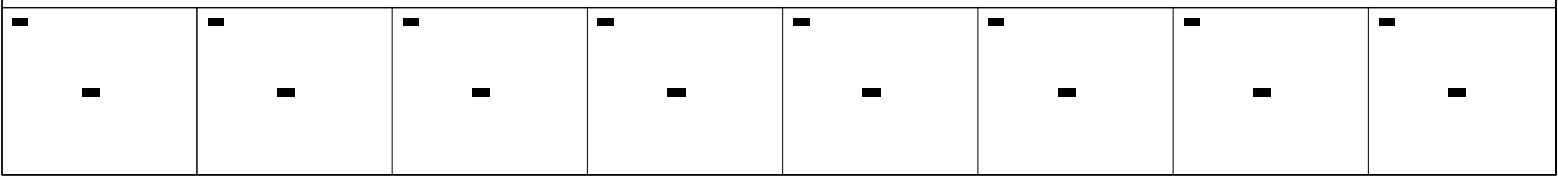
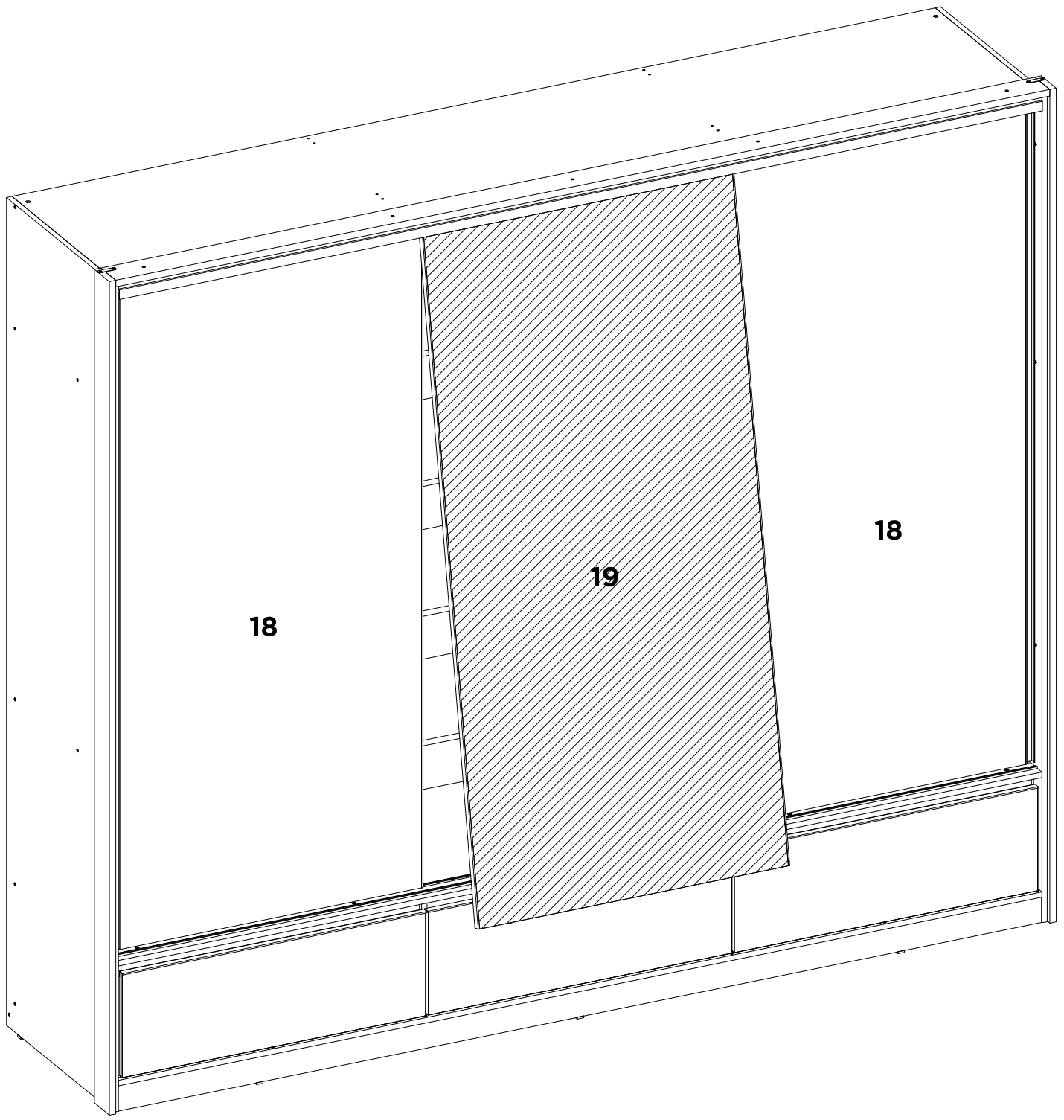

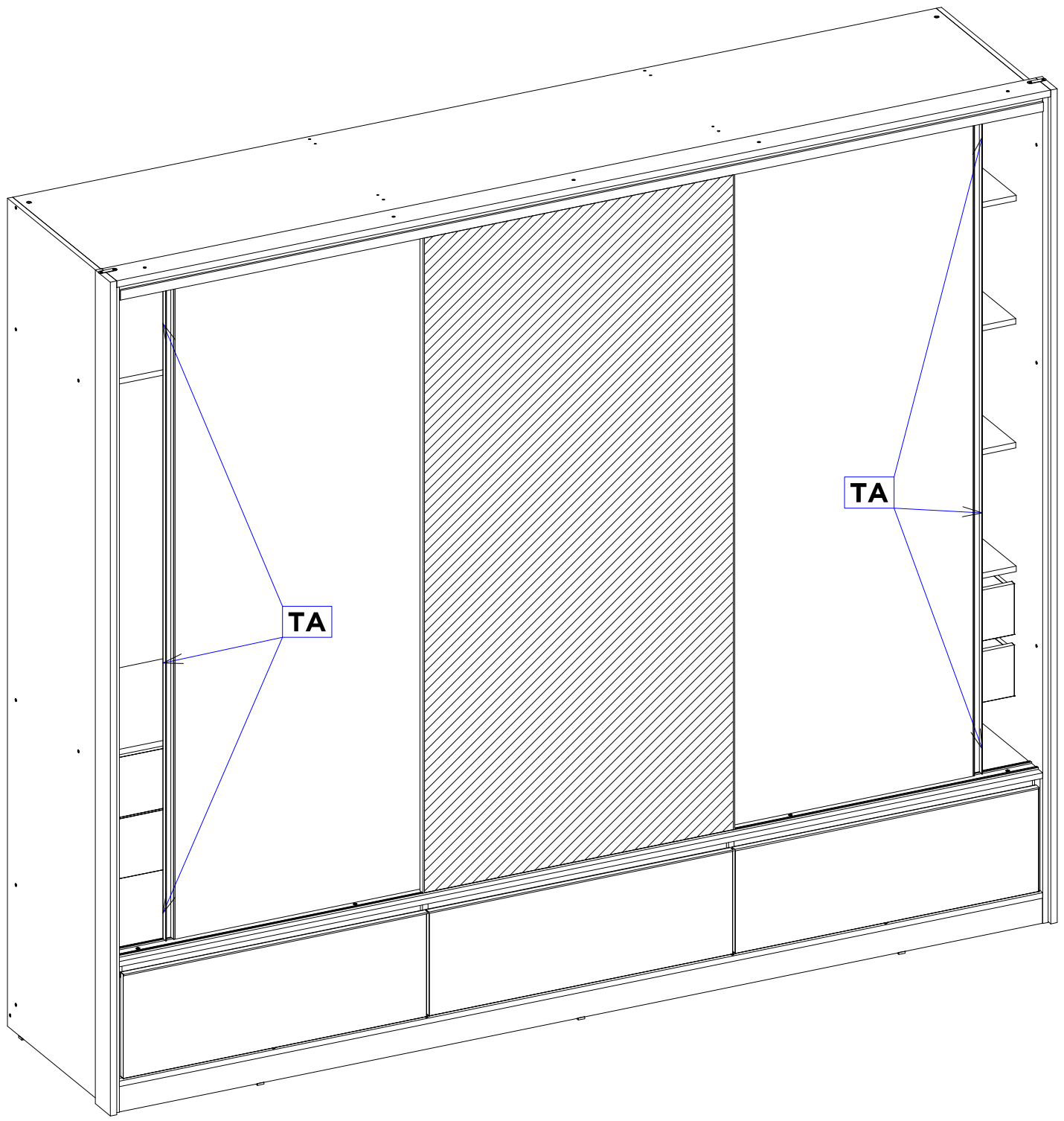

<b>TA</b>	<b>TB</b>	-	-	-	-	-	-
<b>X1</b>	<b>X1</b>	-	-	-	-	-	-

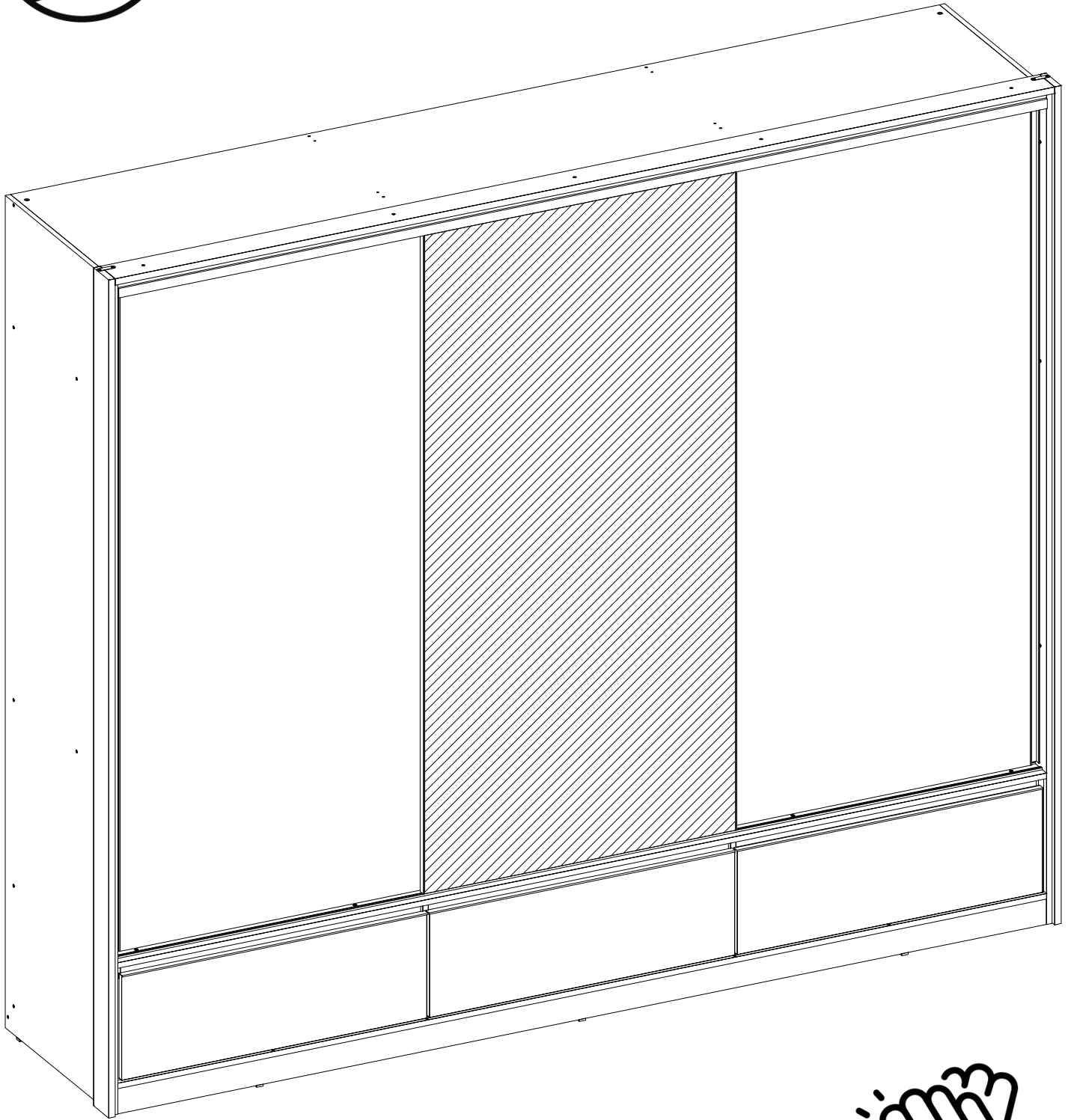

-	-	-	-	-	-	-	-
---	---	---	---	---	---	---	---



DEMARTÊZ

mobília