

ME-4155



Instruções de Montagem Assembly Instructions Instrucciones de Armado

Accesse Vídeos de Montagens
Access Mounting Videos
Acceder a los Vídeos de Montaje
www.tecnomobili.ind.br

tecnomobili

Estrada RSC 453, Km s/n° | Garibaldi | RS
CEP: 95720-000 | Fone / Fax: 54.3464.2050
sac@moveisvideira.com.br

Lista de Peças / List of pieces / Lista de piezas

CóD	DESCRIÇÃO	DESCRIPTION	DESCRIPCIÓN	QTD	RAW MATERIAL	DIMENSION	CÓD
01	Tampo Superior	Upper Top	Tapa Superior	01	MDP 15mm	600x300x15mm	704155
02	Lateral Esquerda	Left Side	Lateral Izquierda	01	MDP 15mm	1360x300x15mm	314155
03	Lateral Direita	Right Side	Lateral Derecha	01	MDP 15mm	1360x300x15mm	304155
04	Costa Superior	Upper Back	Costa Superior	02	MDP 3mm	634x294x3mm	424155
05	Divisão	Division	División	01	MDP 15mm	614x255x15mm	504155
06	Prateleira Móvel Menor	Móble Shelf Smaller	Entrepános Móvil Menor	02	MDP 15mm	276x255x15mm	214155
07	Prateleira Maior	Larger Shelf	Entrepános Maior	01	MDP 15mm	568x300x15mm	204155
08	Tampo	Top	Tapa	01	MDP 15mm	568x300x15mm	714155
09	Costa	Back	Costa	02	MDP 3mm	586x224x3mm	404155
10	Prateleira Móvel	Móble Shelf	Entrepános Móvil	01	MDP 15mm	568x255x15mm	204154
11	Porta Esquerda	Left Door	Puerta Izquierda	01	MDP 15mm	498x280x15mm	94154
12	Porta Direita	Right Door	Puerta Derecha	01	MDP 15mm	498x280x15mm	84154
13	Base	Base	Base	01	MDP 15mm	600x300x15mm	104154
14	Travessa	Traverse	Traviessa	01	MDP 15mm	556x120x15mm	604154
15	Pé Esquerdo Tubo	Left Tube Foot	Pié Tubo Izquierdo	01	Tubo 20x20mm	296x200x15mm	8606-8608
16	Pé Direito Tubo	Right Tube Foot	Pié Tubo Derecho	01	Tubo 20x20mm	296x200x15mm	8605-8607

Notas Especiais:

01 -Examine completamente todas as peças do móvel antes de começar o trabalho.

02 -Recomenda-se montar o móvel conforme este Manual de Montagem.

03 -É de responsabilidade do montador seguir as instruções do Manual de Montagem, que são fundamentais para garantir a estrutura do móvel.

04 -Para limpeza, utilizar somente pano úmido e sabão neutro.

Special notes:

01 -Check all parts of the unit thoroughly before starting work.

02 -It is recommended to assemble the furniture according to this Installation Manual.

03 -It is the responsibility of the assembler to follow the instructions in the Assembly Manual, which are essential to ensure the structure of the furniture.

04 -For cleaning use only damp cloth and neutral soap.

Notas especiales:

01 -Examine completamente todas las piezas del mueble antes de iniciar el trabajo.

02 -Se recomienda montar el mueble conforme el Manual de Ensamblaje.

03 -Es de responsabilidad del montador seguir las instrucciones del Manual de Ensamblaje, que son fundamentales para garantizar la estructura del mueble.

04 -Para limpieza solamente usar trapo húmedo y jabón neutro.

Guarante certificate:

The guarantee of products manufactured by Móveis Videira LTDA covers any defects / manufacturing defects, within the period established by the Consumer Protection Code, in its Article 26, II, which provides for a legal guarantee of ninety (90) days.

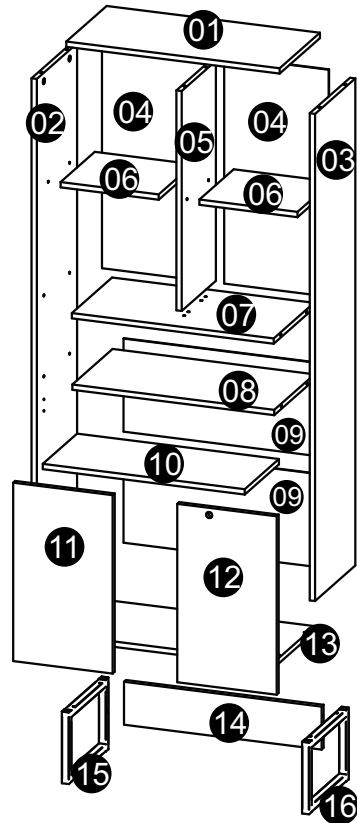

M		34 x 7mm Parafuso Minifix	17	3771
N		15 x 12mm Tambor Minifix	21	9516
O		Rosca M6 Parafuso Minifix	04	8604
P		Distânciador	01	6516
Q		Tapa Furo	05	
R		40 x 25 x 1,55mm Batente	01	6523

TAMANHO REAL - TAMANO VERDADERO - REAL SIZE

REF	DESCRIÇÃO	QTD	cód
A	 Parafuso 3,5 x 40mm CC	02	8115
B	 3,5 x 16mm CC	20	8096
C	 Cavilha 8 x 30mm	03	2806
D	 3,5 x 14mm CF	04	3759
E	 Parafuso 3,5 x 30mm CF	04	8143

LUSTRAÇÃO - ILUSTRACION - ILLUSTRATION

REF	DESCRIÇÃO	QTD	cód
F	 80x48x31mm Dobradiça Curva Calço n° 12	04	8599
G	 Puxador	02	5169
H	 Fechadura	01	5474
I	 Ponteira Quadrada 20x20	04	8603
J	 14 x 8 x 5mm Suporte Prateleira 5x8	14	3748
K	 22 x 3mm Prego 10x10	50	3051
L	 13 x 13 x 3mm Fixador de Costa	04	6524

Ferramentas | Tools | Herramientas

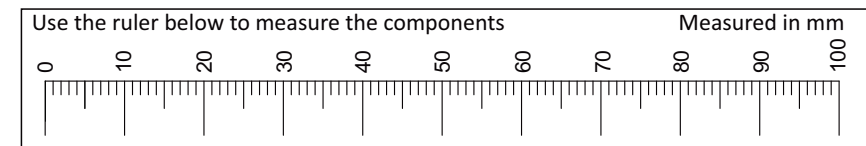
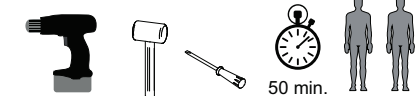

Revisão: 00
Data: 06/07/2020

