

MANUAL COMPLETO COMPLETE MANUAL

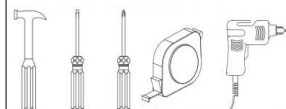

DEMÓBILE Indústria de Móveis Ltda.
Rua : Jurutau, 1350 - Pq. Industrial II.
Cep.: 86703-070
Arapongas - PR - Brasil
demobile@demobile.com.br



Avisos

1. Ler atentamente as instruções do manual antes de iniciar a montagem do móvel.
2. A montagem deverá ser feita em superfície limpa e plana, aconselhamos forrar o chão com a embalagem do produto, para não danificar.
3. Os parafusos devem ser apertados periodicamente.
4. Evitar batidas e contato com objetos cortantes.
5. O peso máximo de carga informado refere-se a objetos distribuídos de maneira uniforme sobre toda área de contato da peça.

Limpeza e Conservação

Efetuar a limpeza somente com pano macio limpo e seco.
Não Utilizar produtos abrasivos ou químicos.

Garantia

1. O fabricante responsabiliza-se apenas pelas peças do produto.
2. A montagem incorreta acarretará na perda da garantia e das assistências, desta forma o produto deverá ser montado por profissional qualificado.
3. Não estão cobertos pela garantia problemas que tenham origem na utilização inadequada do produto ou na exposição do mesmo a intempéries como: infiltrações, infestação de pragas em geral, aparecimento de mofo e outros, decorrentes do ambiente de instalação.

Assistência Técnica: Em caso de peças em assistência técnica é necessário que as mesmas sejam solicitadas junto a loja ou site no qual a compra do produto foi realizada

Warnings

1. Read the manual instructions carefully before starting to assemble the furniture.
2. The assembly must be done in clean and flat surface, we advise to put the product packaging on the floor, not to damage it during the assembling.
3. The screws must be tightened periodically.
4. Avoid hitting and contacting sharp objects.
5. The payload informed refers to the objects distributed all over the piece contact area.

Cleaning and conservation

Clean the product just with a soft, cleaned and dry cloth.
Do not use abrasive or chemicals products.

Warranty

1. The manufacturer is only responsible for product parts.
2. Incorrect assembling will make you lost the guarantee and assistance, in this way the product must be assembled by qualified professional.
3. It is Not covered by the warranty problems caused by an inappropriate use of the product or product exposure even in bad weather, such as: infiltrations, pest infestation in general, appearance of mold and others, caused by the installation environment.

Technical Assistance: Damaged pieces! Ask on the stores you bought it.

Advertencias

1. Lee atentamente las instrucciones del manual antes de empezar a armar los muebles.
2. El montaje debe hacerse en superficie limpia y plana, utilice el empaque del Producto para cubrir el piso
3. Los tornillos deben ser apretados periódicamente
4. Evite golpear y chocar objetos punzantes
5. El peso máximo de carga tiene relación a los objetos distribuydos sobre toda el área de contacto de la pieza.

Limpeza y conservación

Limpiar solo con un trapo suave, limpio y seco
No utilice productos abrasivos o productos químicos

Garantía

1. El fabricante solo es responsable a las partes del producto.
2. Armar incorrectamente supone la pérdida de garantía y repuestos, de esta manera el producto debe ser ensamblado por profesional calificado
3. No es garantizado problemas derivados del uso inapropiado del producto, o exposición del producto al mal tiempo, como: infiltraciones, infestación de plagas en general, aparición de moho y otros.

Asistencia técnica: en caso de piezas rotas es necesario que sea solicitadas las mismas a la tienda o sitio web donde se compró el producto.

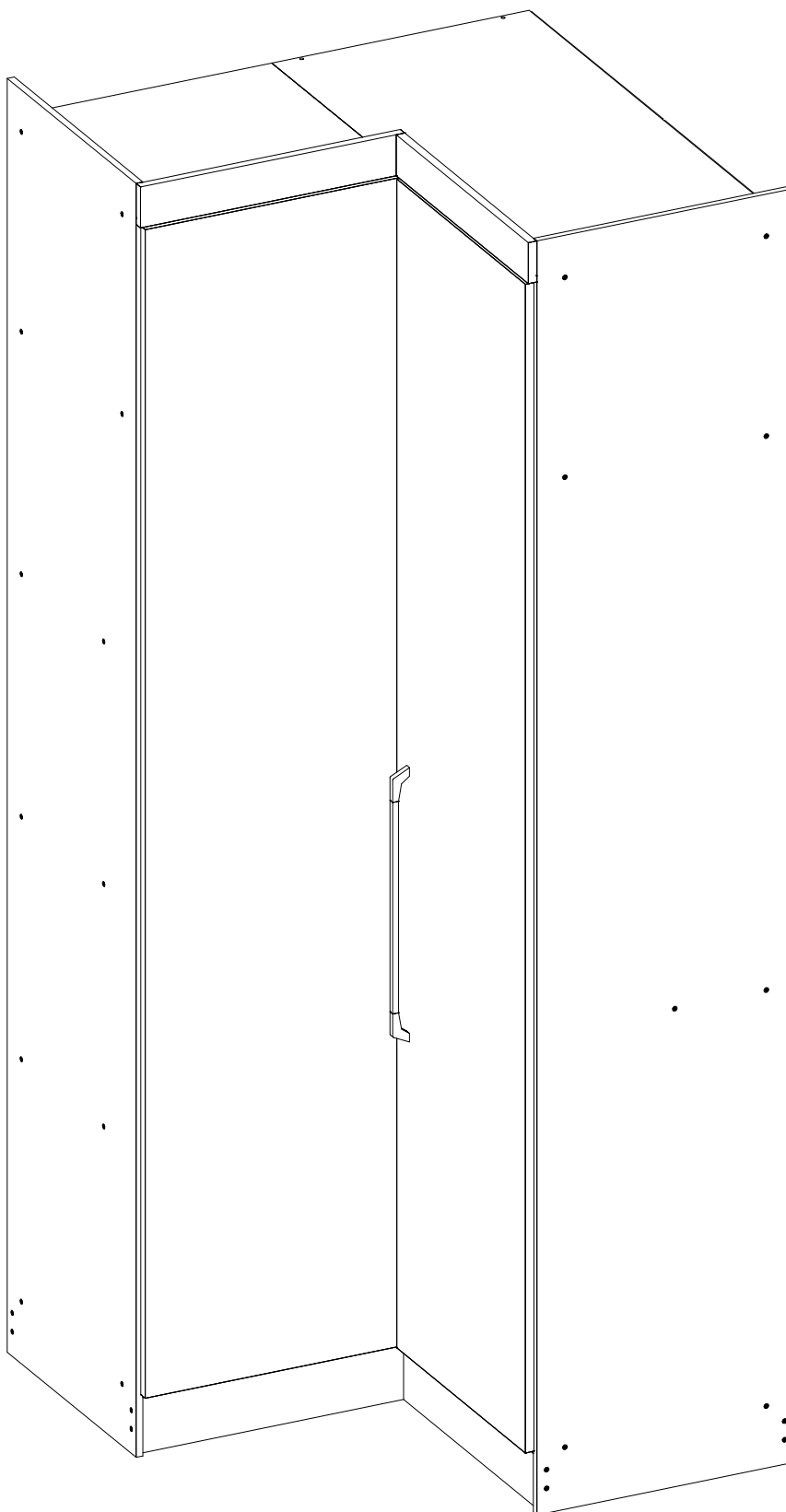

78200 ARMARIO DE CANTO L MODENA

78200 EDGE WARDROBE MODENA

78200 ARMARIO ESQUINERO MODENA

01

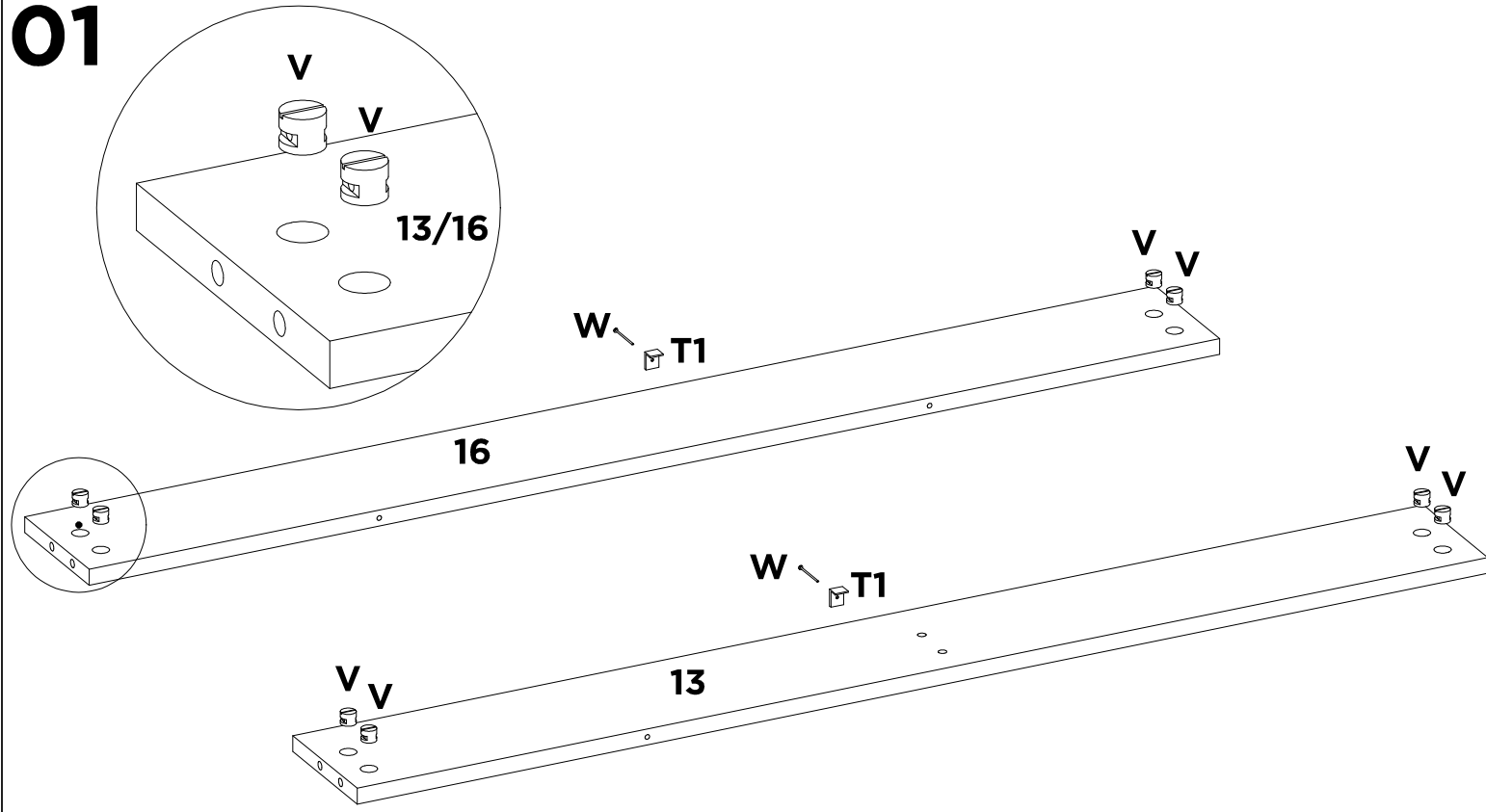

V	T1	W	-	-	-	-	-
X8	X2	X2	-	-	-	-	-

01A

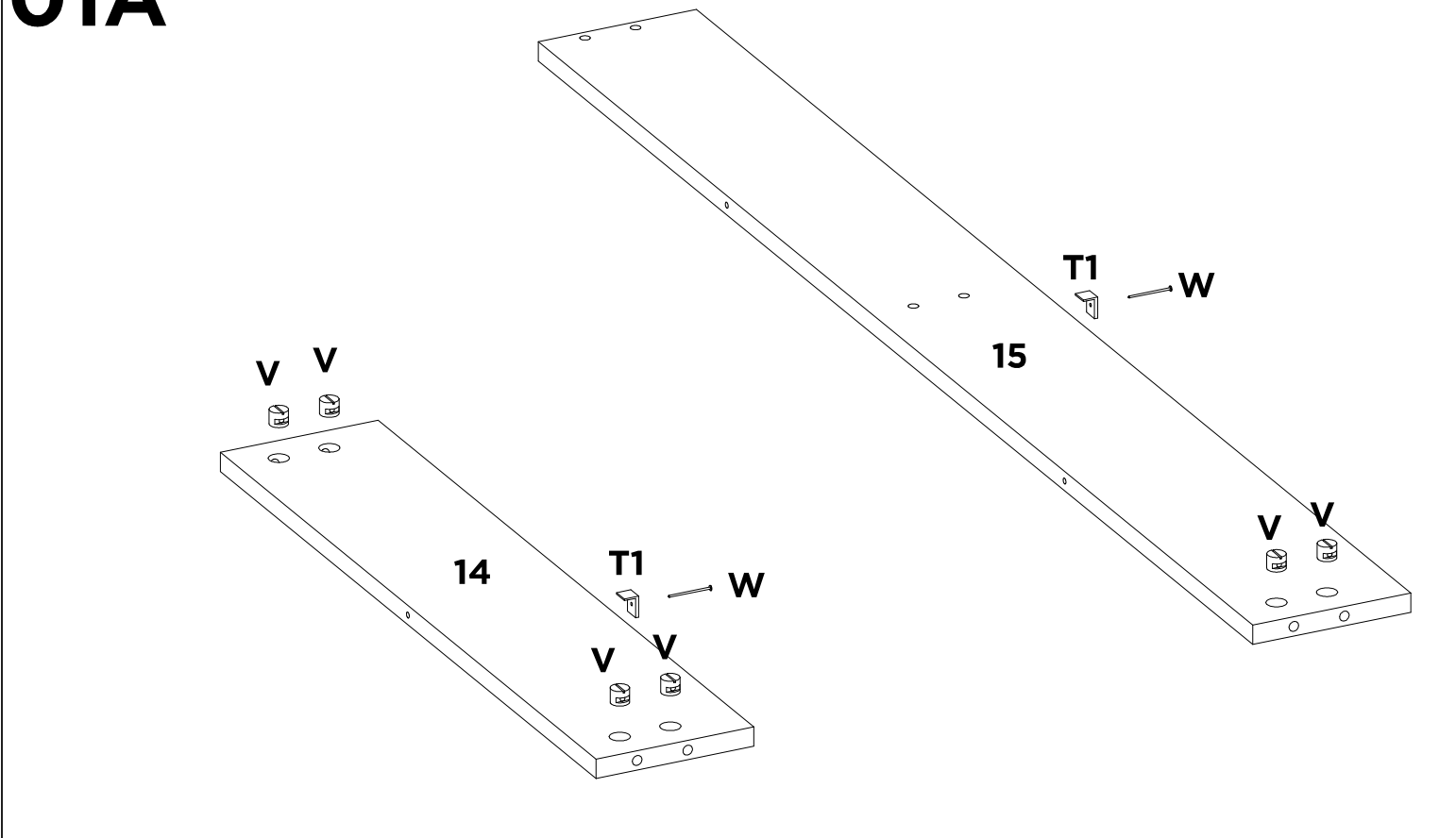

V	T1	W	-	-	-	-	-
X6	X2	X2	-	-	-	-	-

02

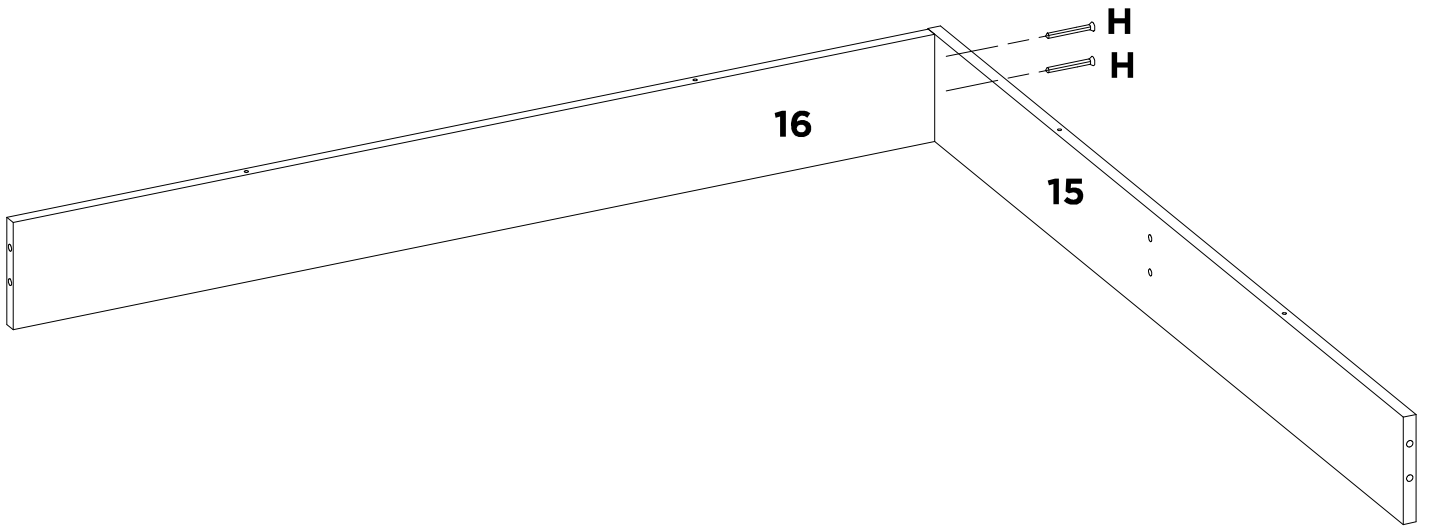

H	-	-	-	-	-	-	-
X2	-	-	-	-	-	-	-

02A

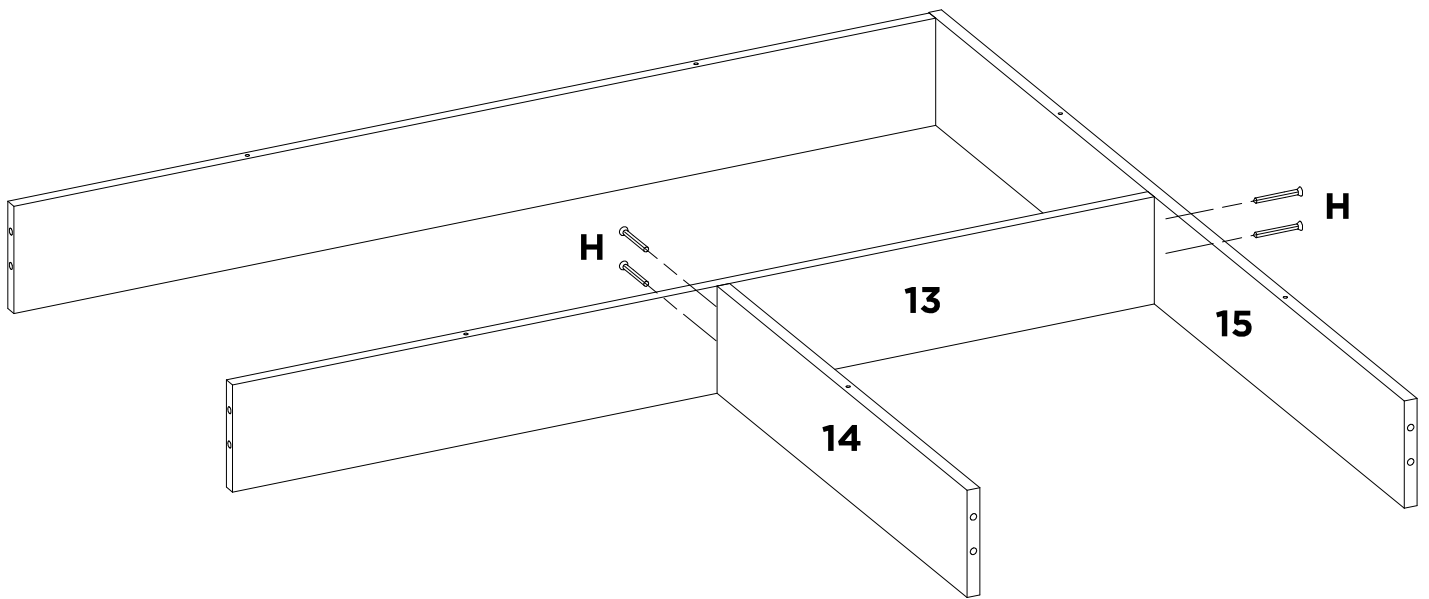

H	-	-	-	-	-	-	-
X4	-	-	-	-	-	-	-

03

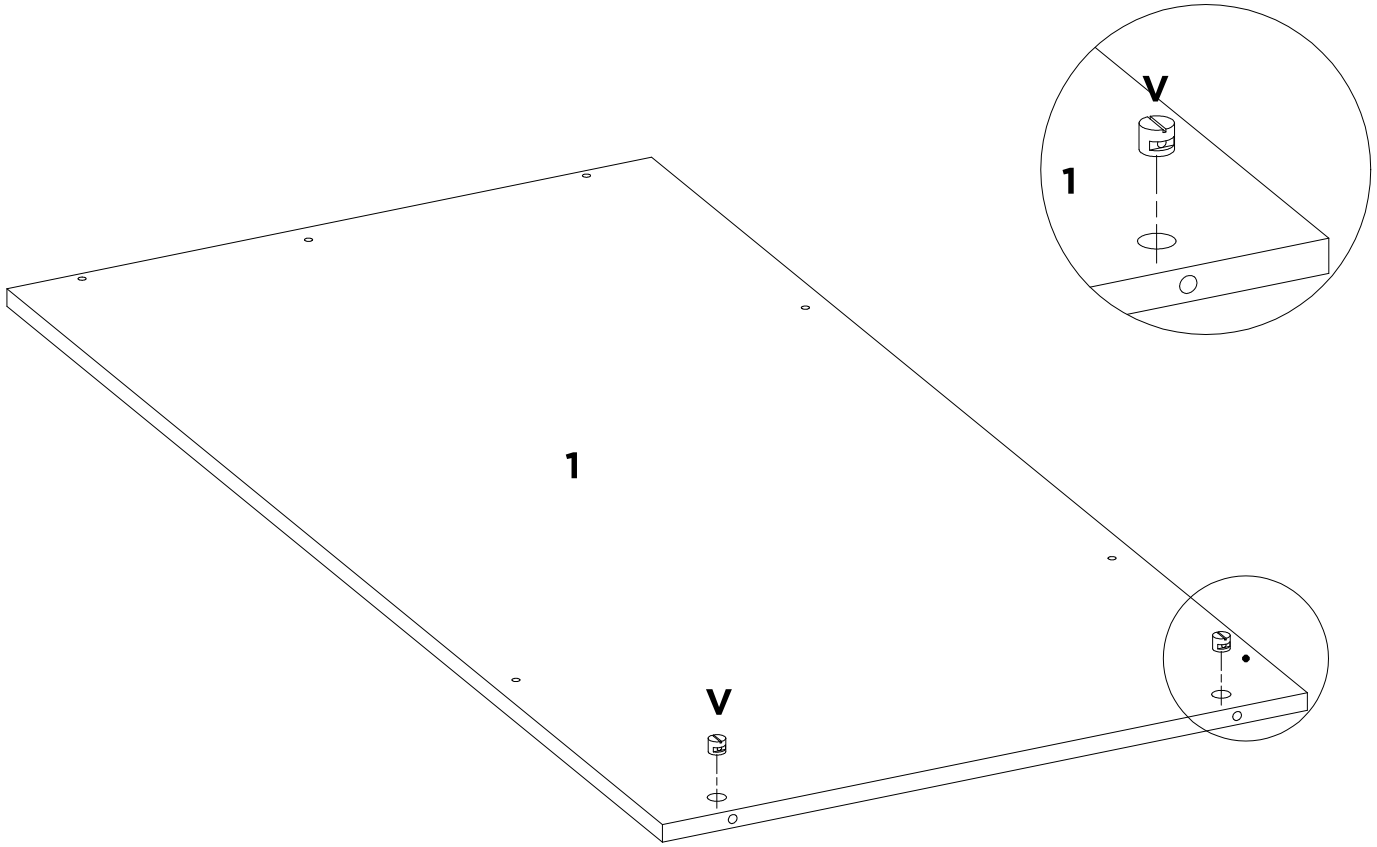

V	-	-	-	-	-	-	-	-
X2	-	-	-	-	-	-	-	-

03A

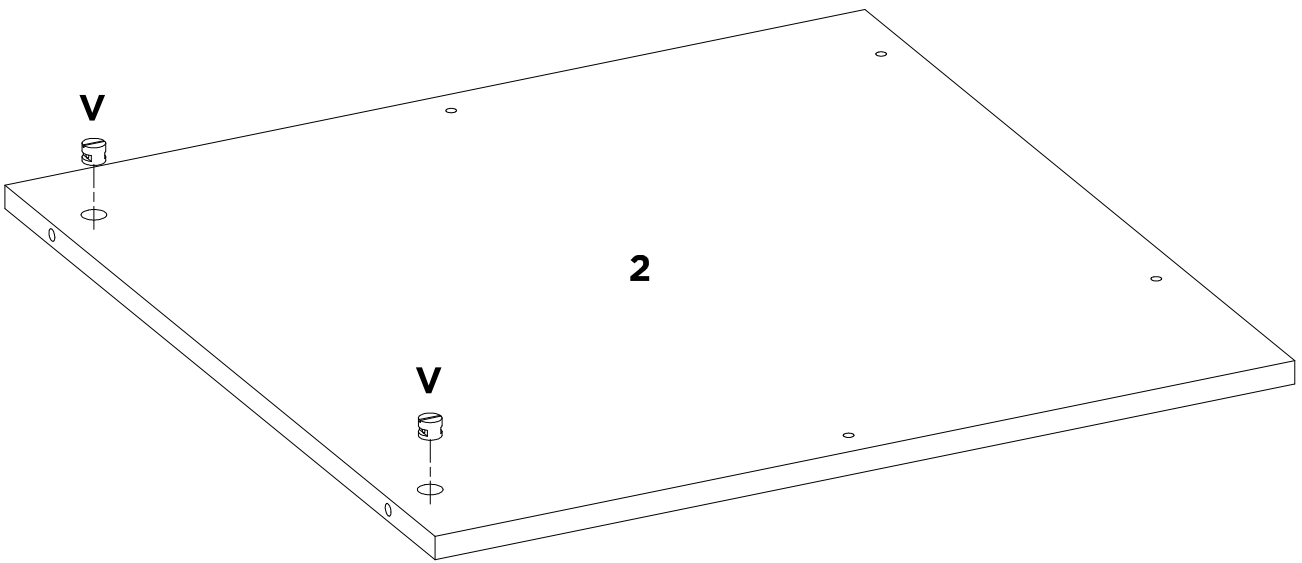

V	-	-	-	-	-	-	-	-
X2	-	-	-	-	-	-	-	-

04

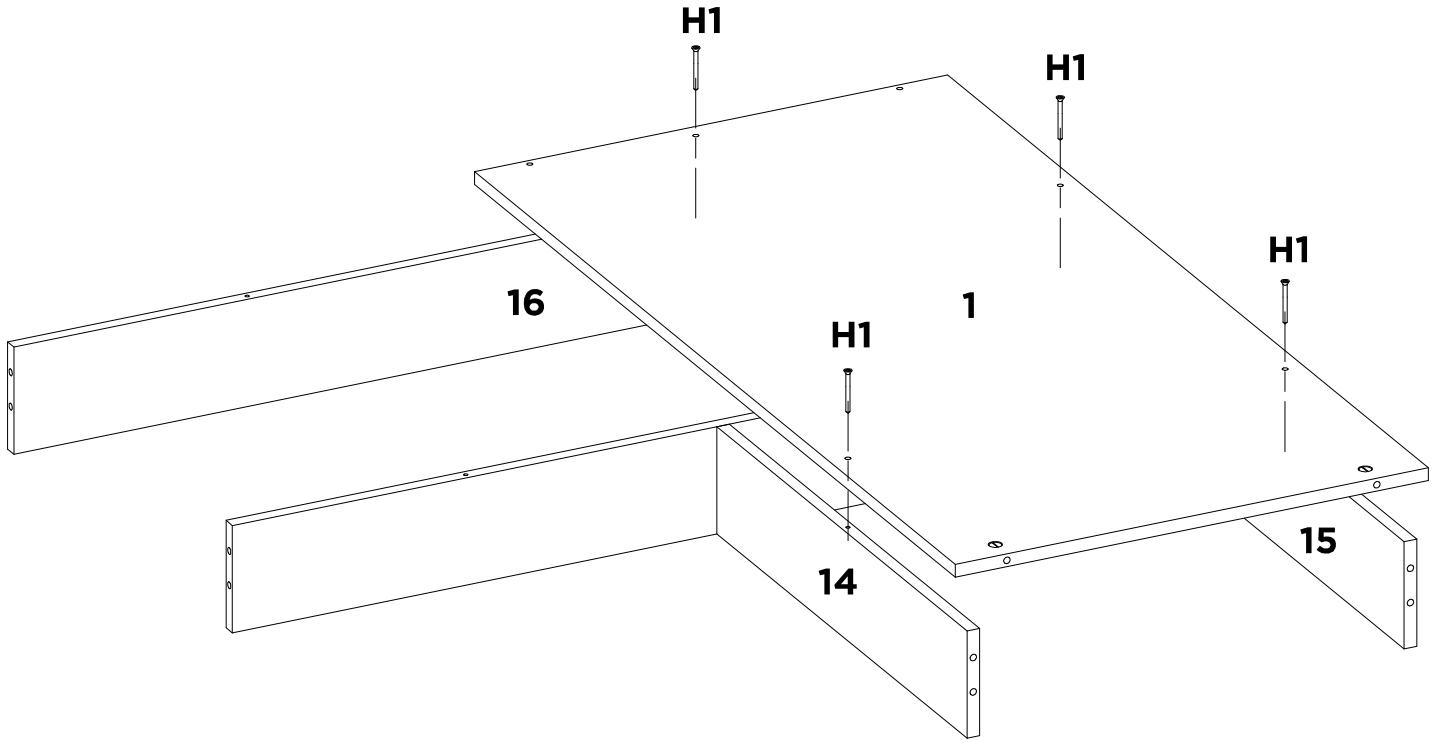

H1	-	-	-	-	-	-	-
X4	-	-	-	-	-	-	-

04A

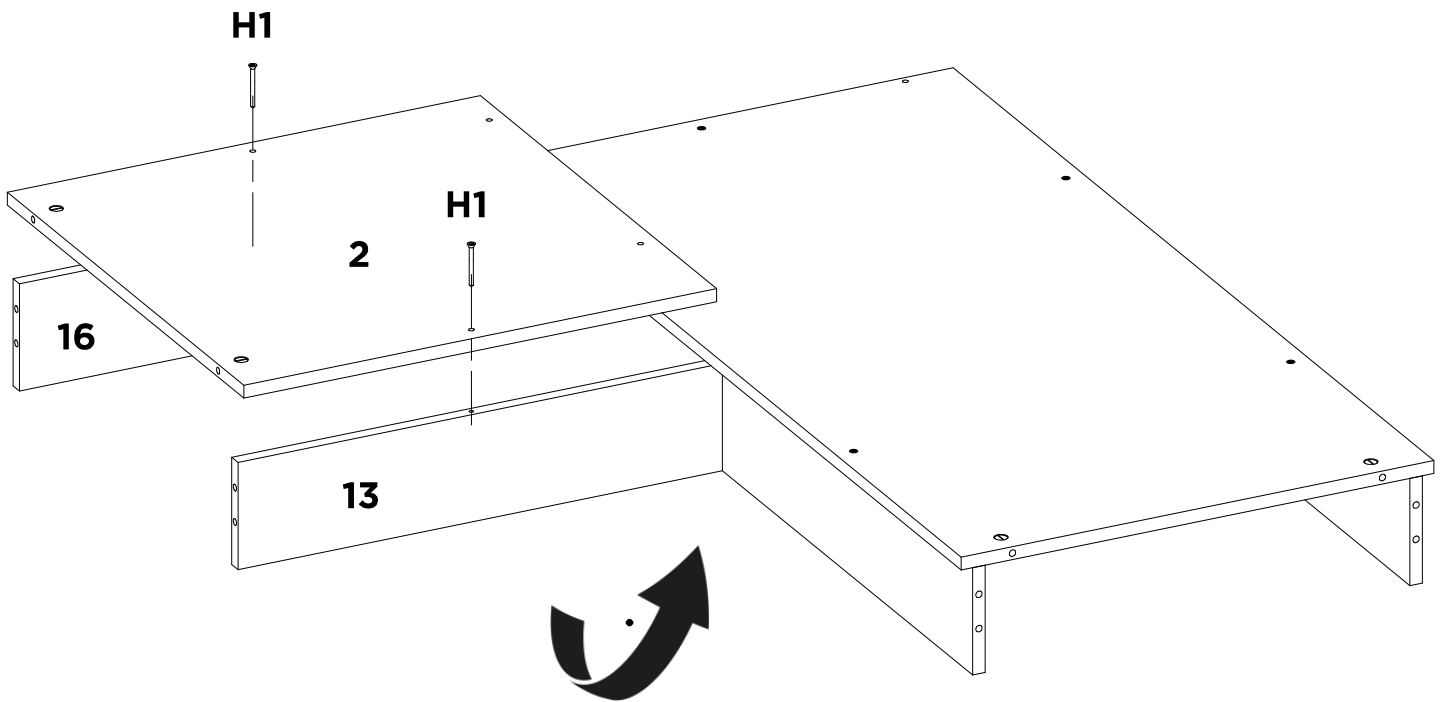

H1	-	-	-	-	-	-	-
X2	-	-	-	-	-	-	-

05

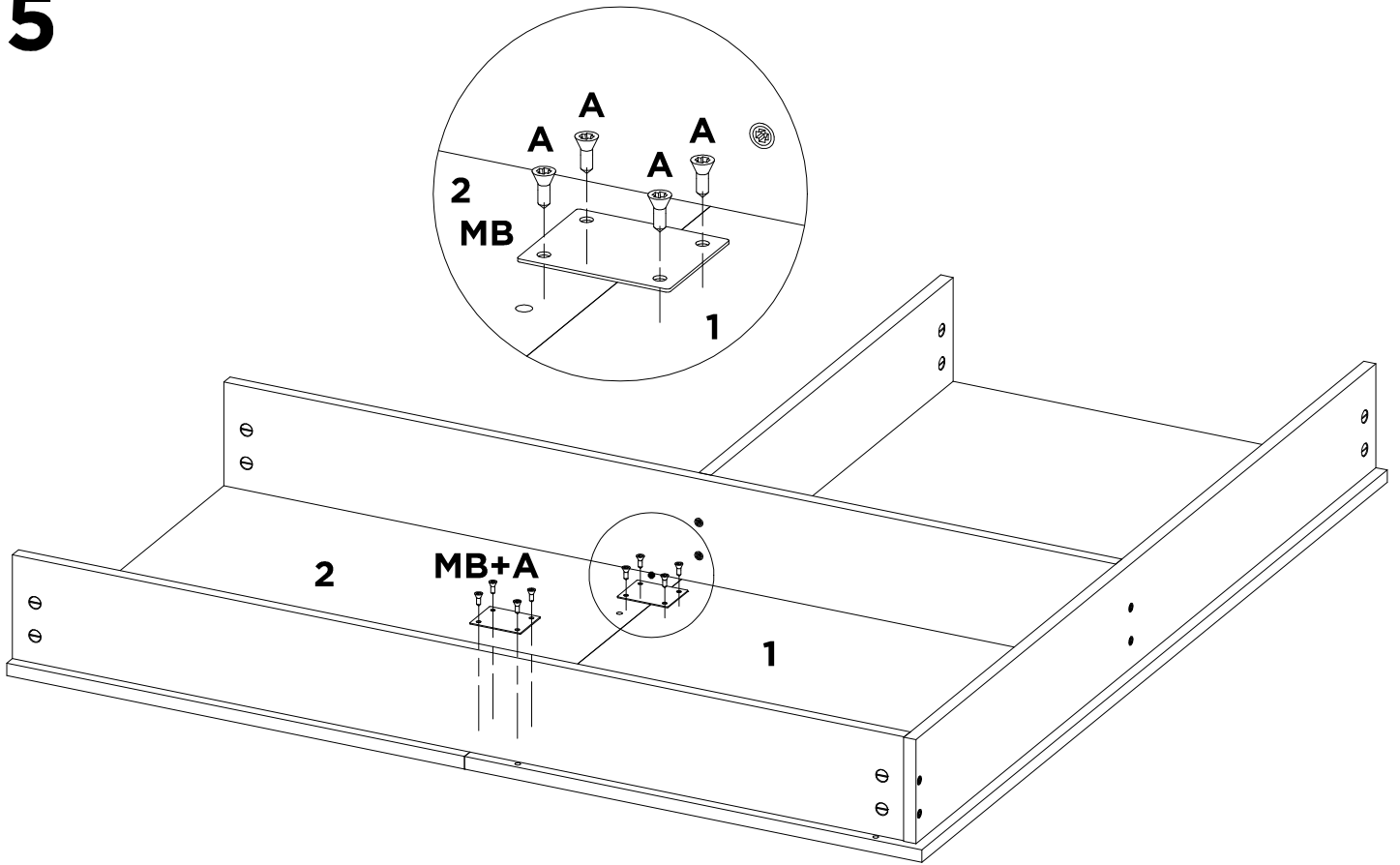

A	MB	-	-	-	-	-	-
X8	X2	-	-	-	-	-	-

05A

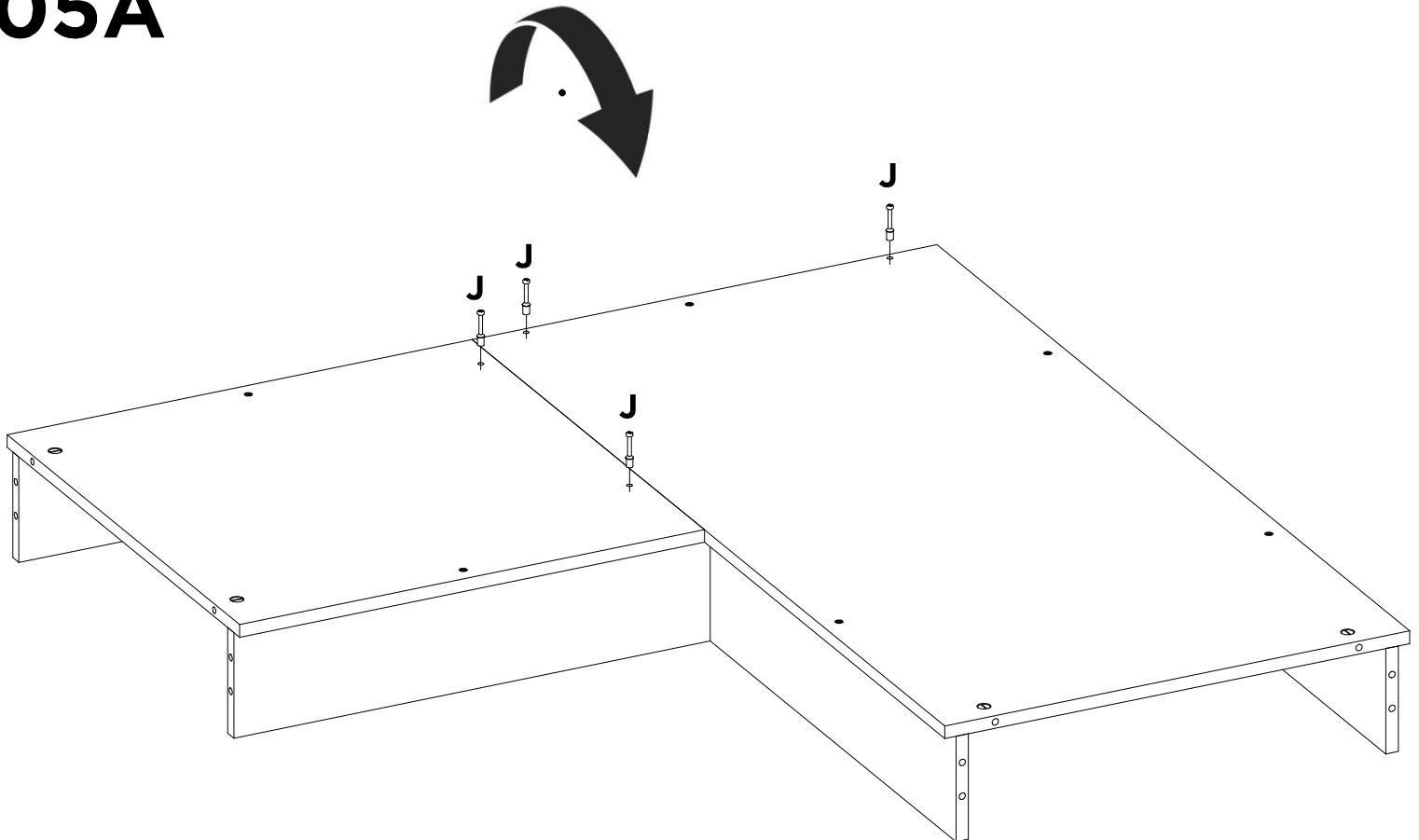

J	-	-	-	-	-	-	-
X4	-	-	-	-	-	-	-

06

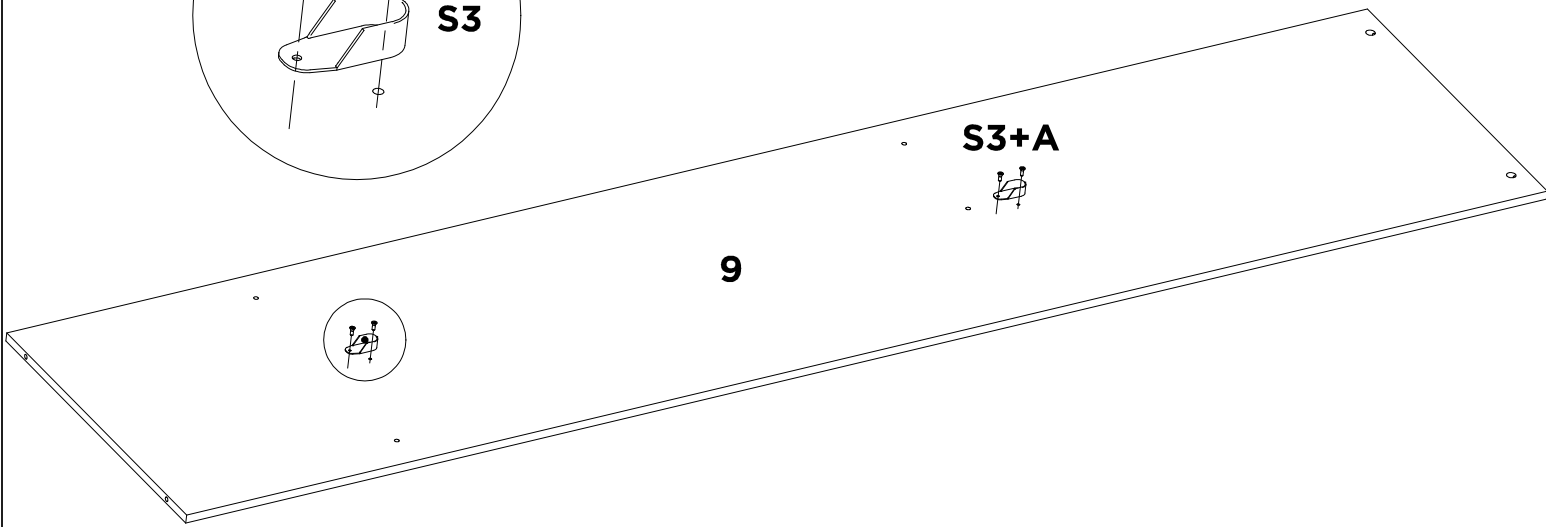
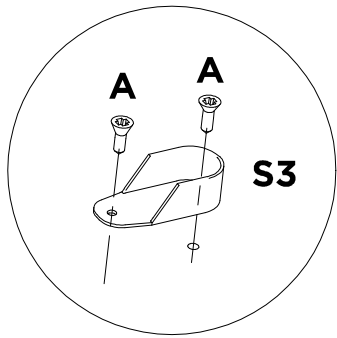

A	S3	-	-	-	-	-	-
X4	X2	-	-	-	-	-	-

06A

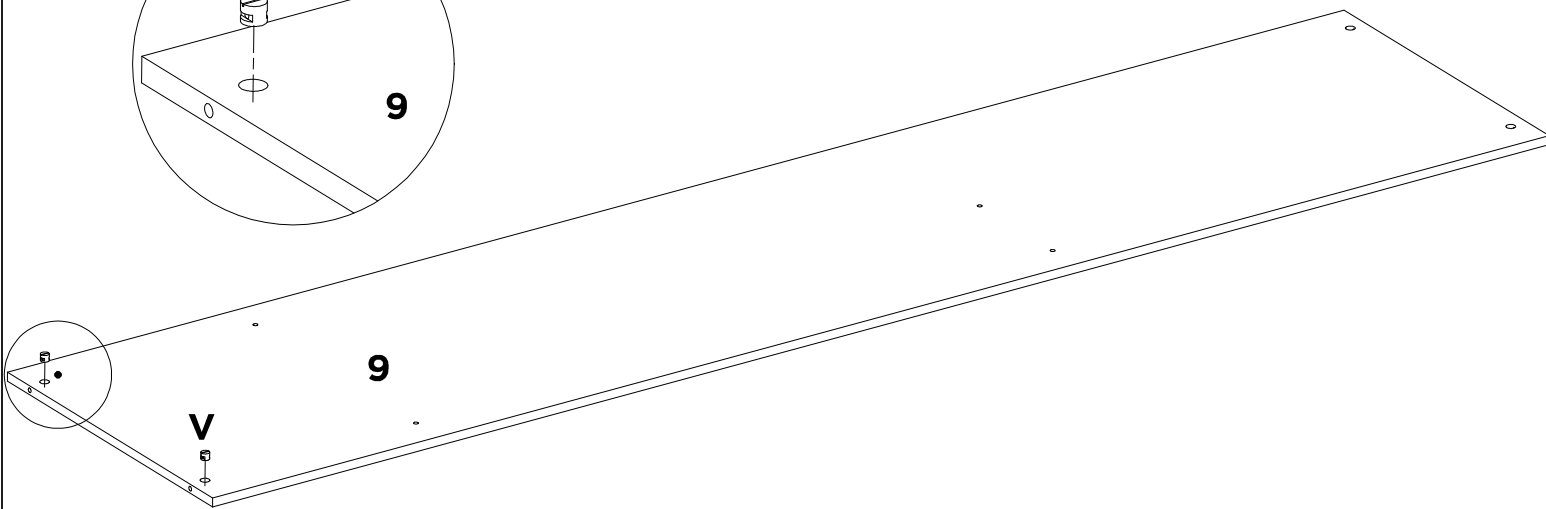
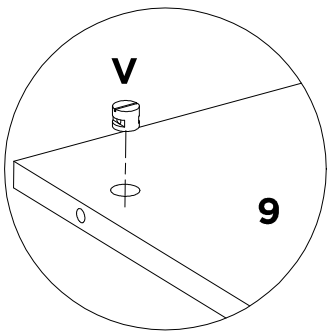

V	-	-	-	-	-	-	-
X2	-	-	-	-	-	-	-

07

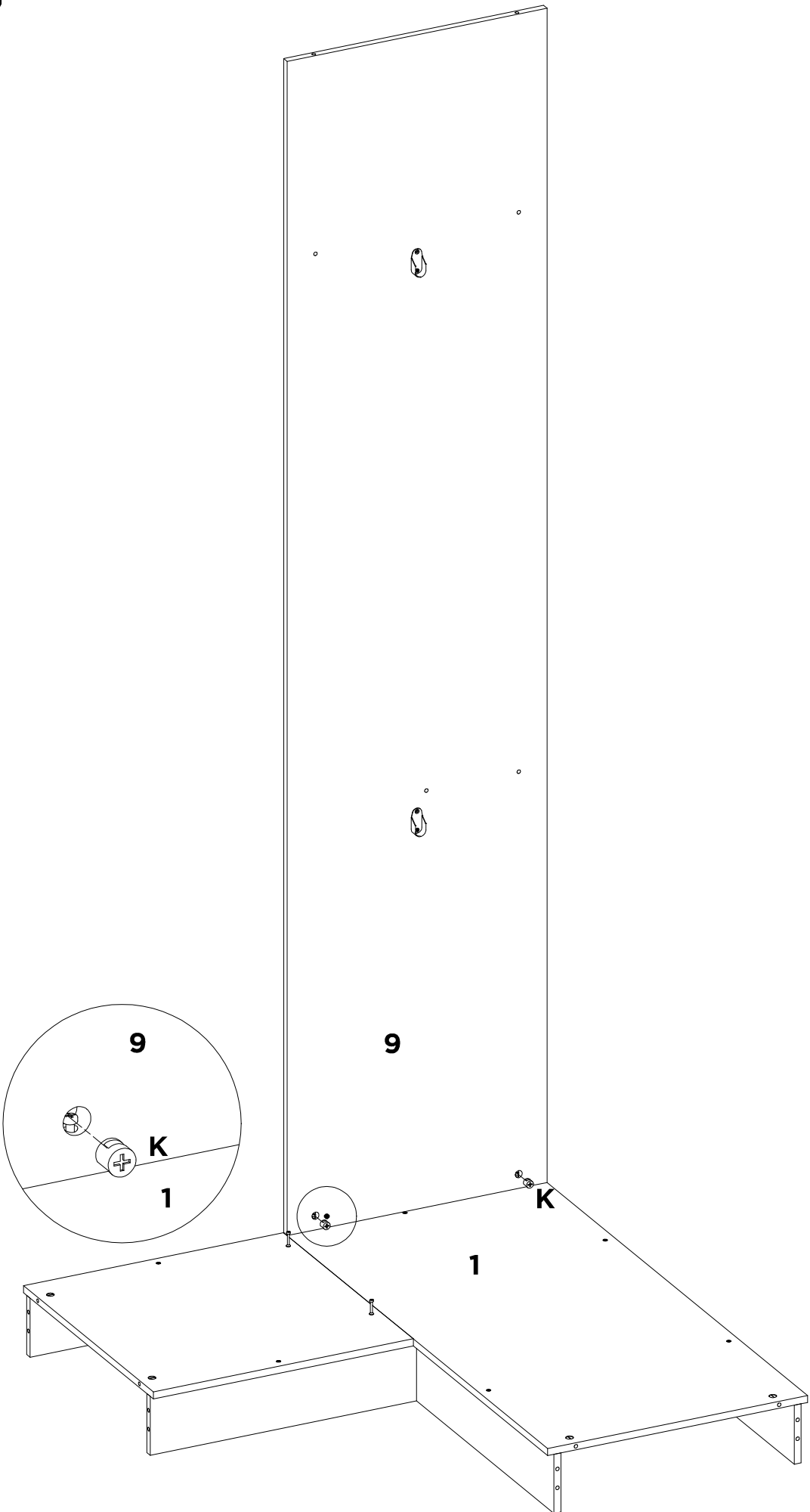

K	-	-	-	-	-	-	-
X2	-	-	-	-	-	-	-

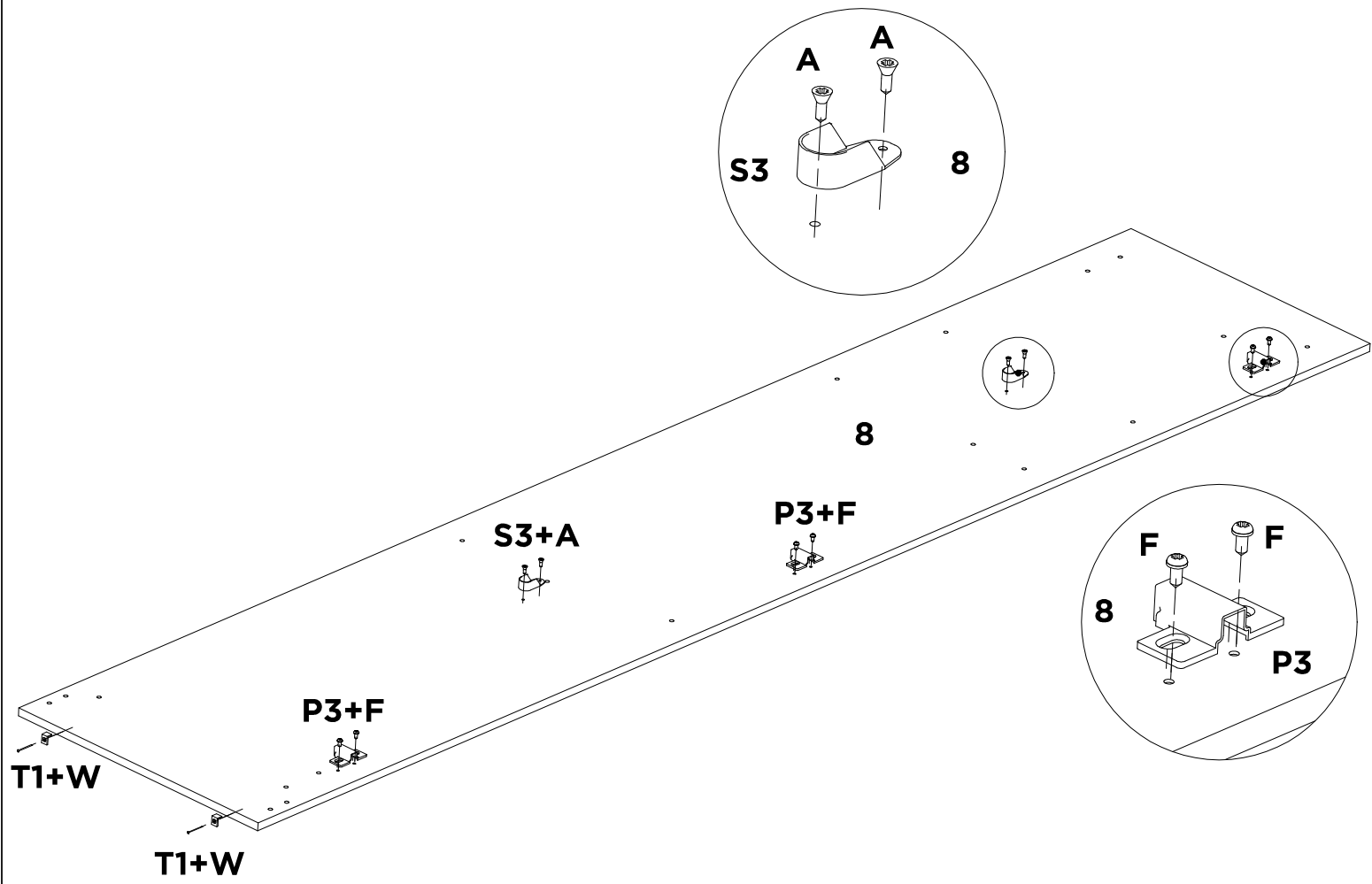

T1	P3	F	S3	A	W	-	-
X2	X3	X6	X2	X4	X2	-	-

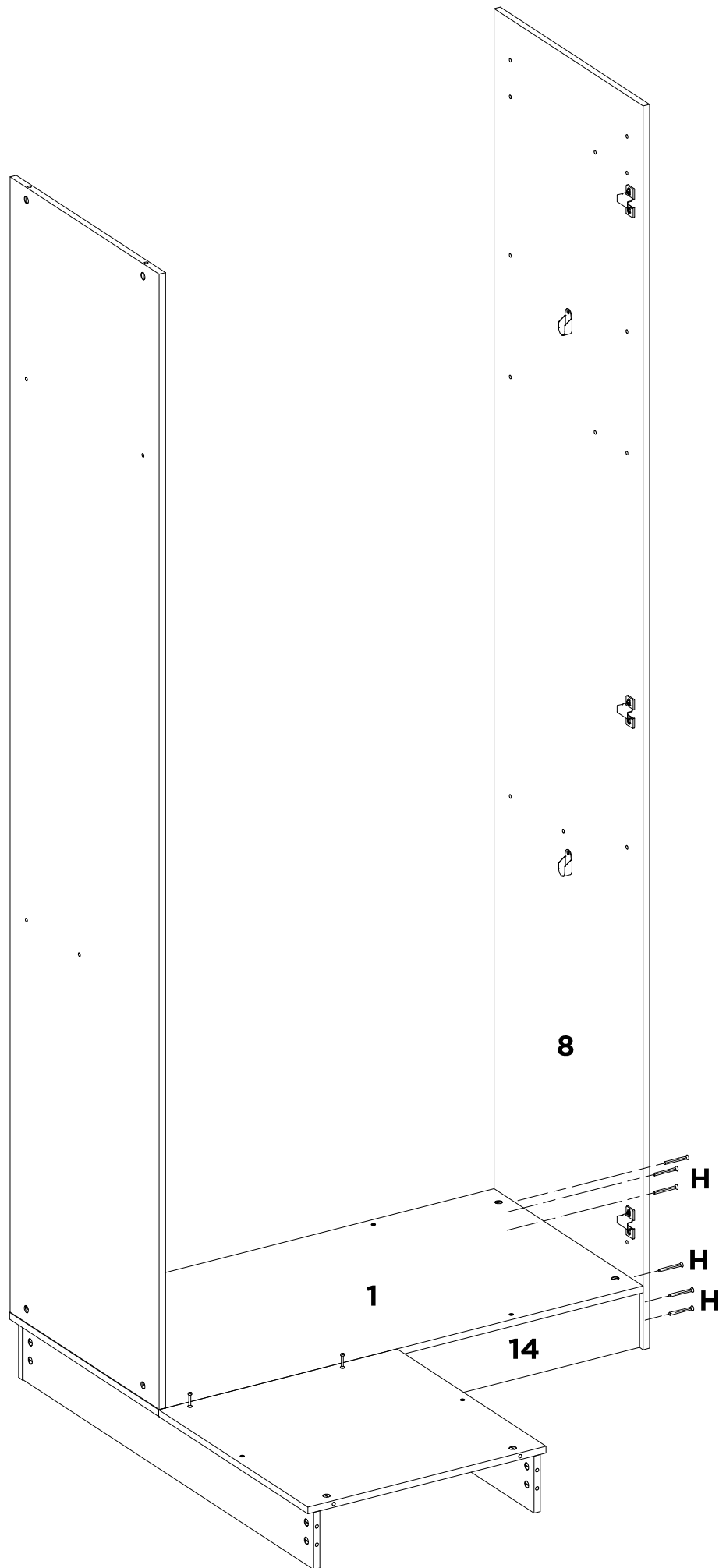

H	-	-	-	-	-	-	-
X6	-	-	-	-	-	-	-

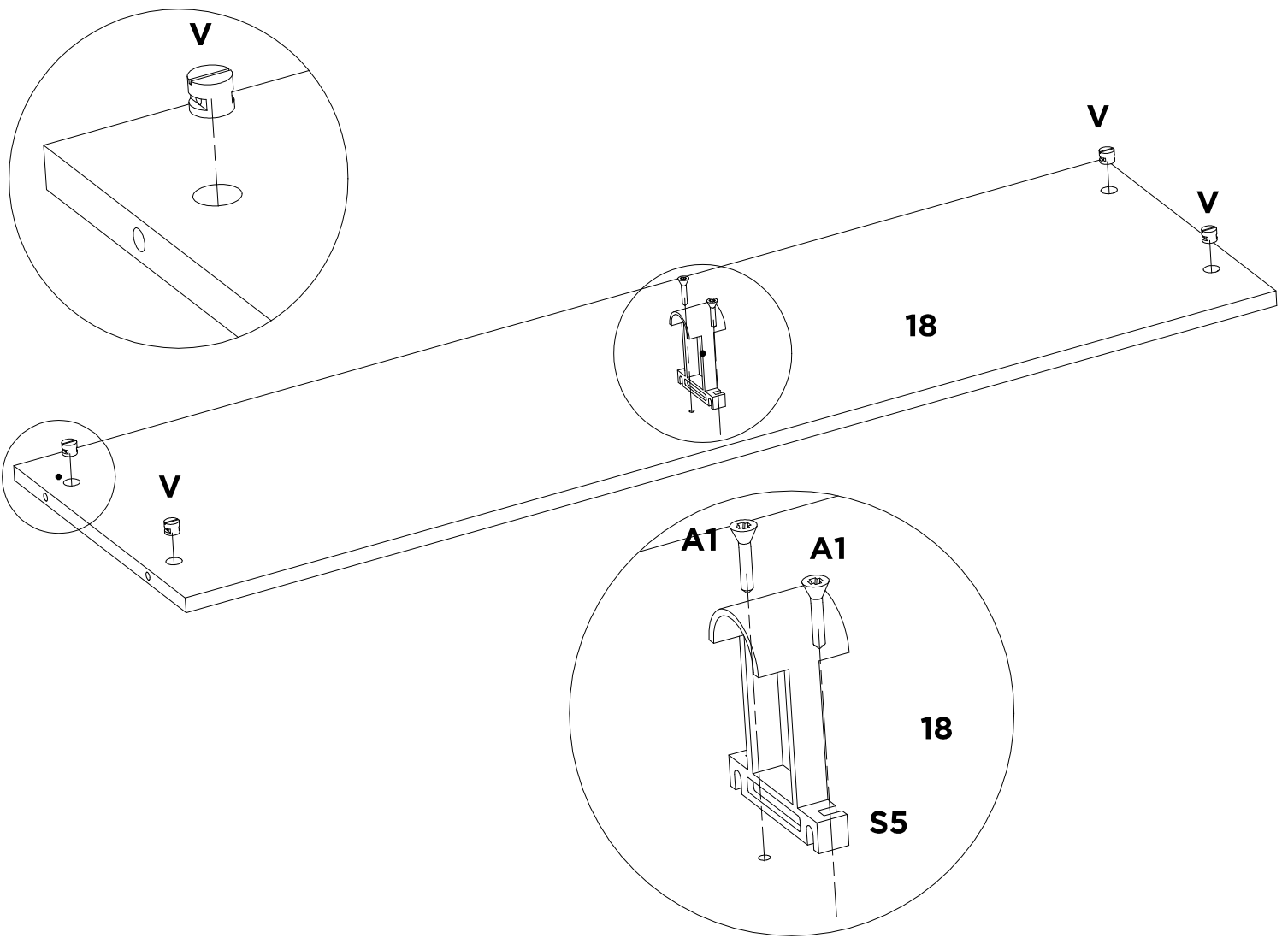

V	A1	S5	-	-	-	-	-
X4	X2	X1	-	-	-	-	-

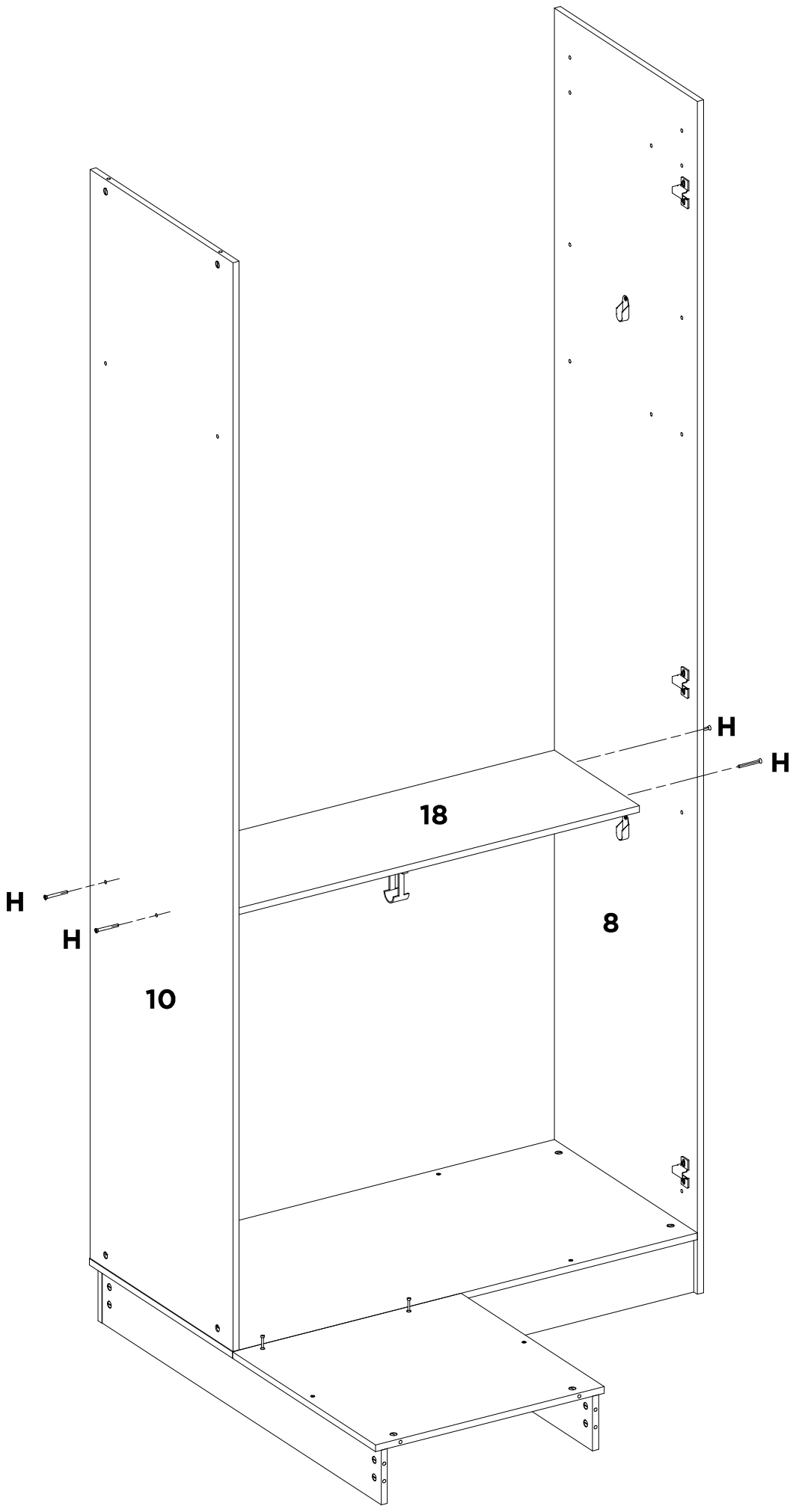

H	-	-	-	-	-	-	-
X4	-	-	-	-	-	-	-

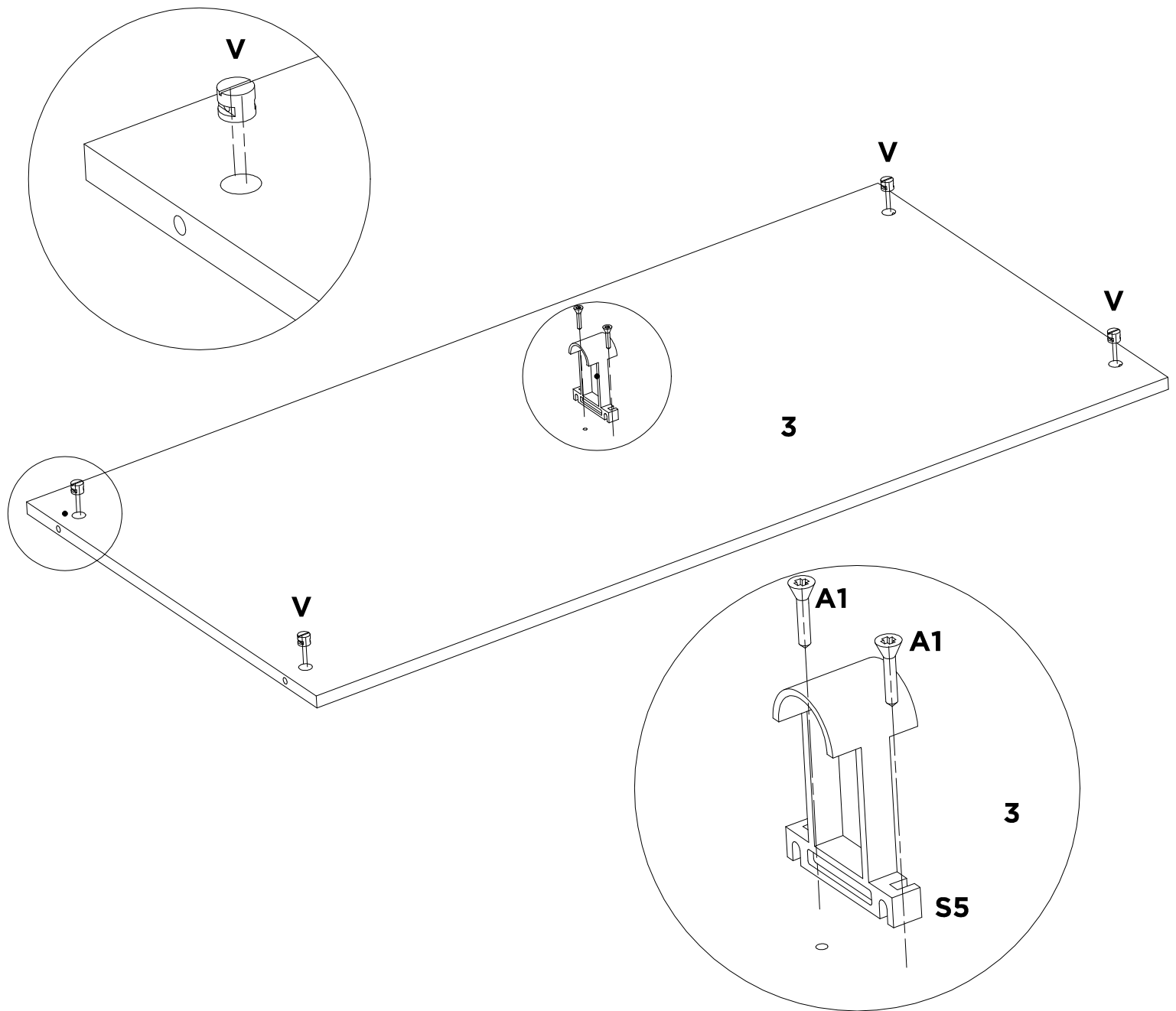

V	A1	S5	-	-	-	-	-
X4	X2	X1	-	-	-	-	-

13

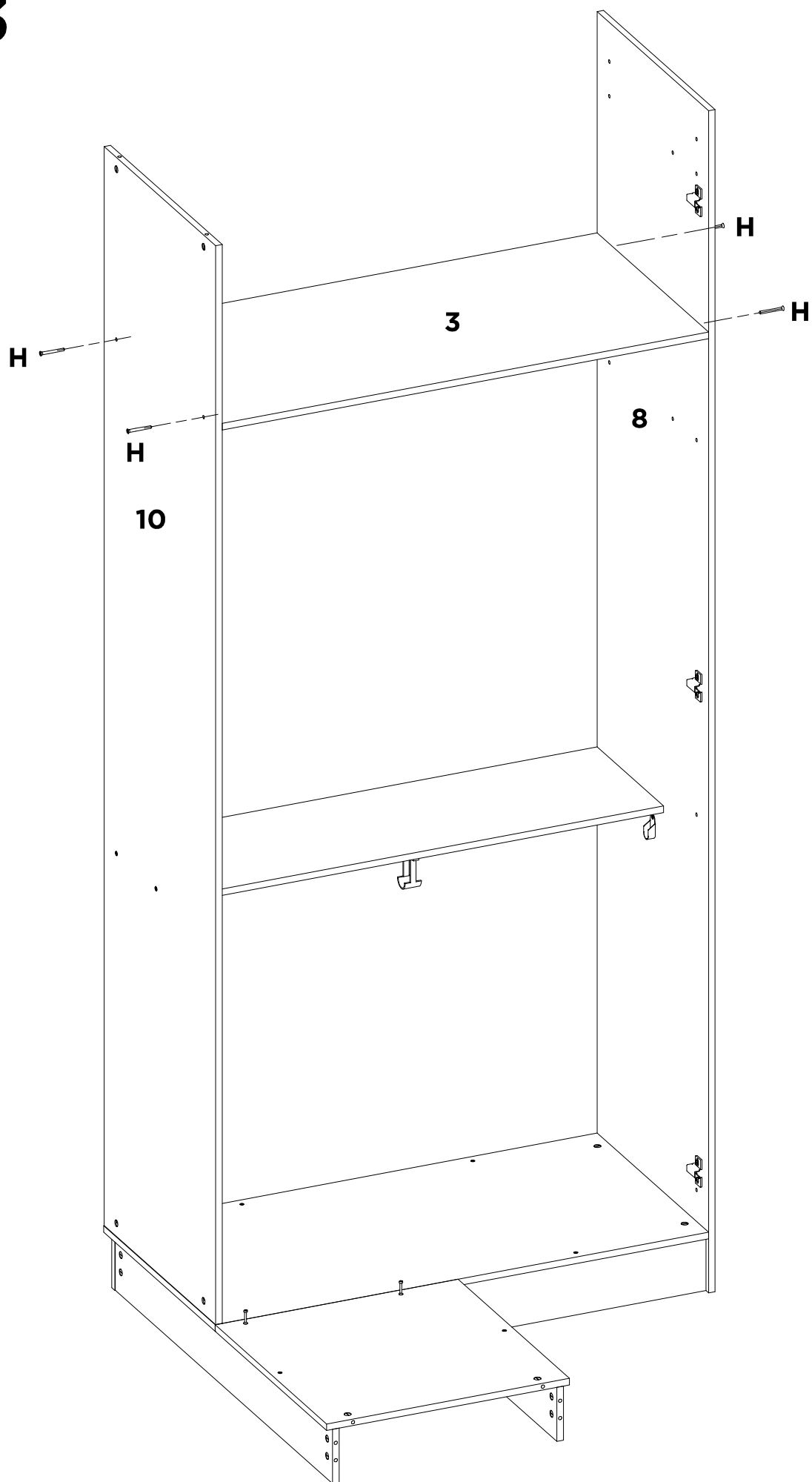

H	-	-	-	-	-	-	-
X4	-	-	-	-	-	-	-

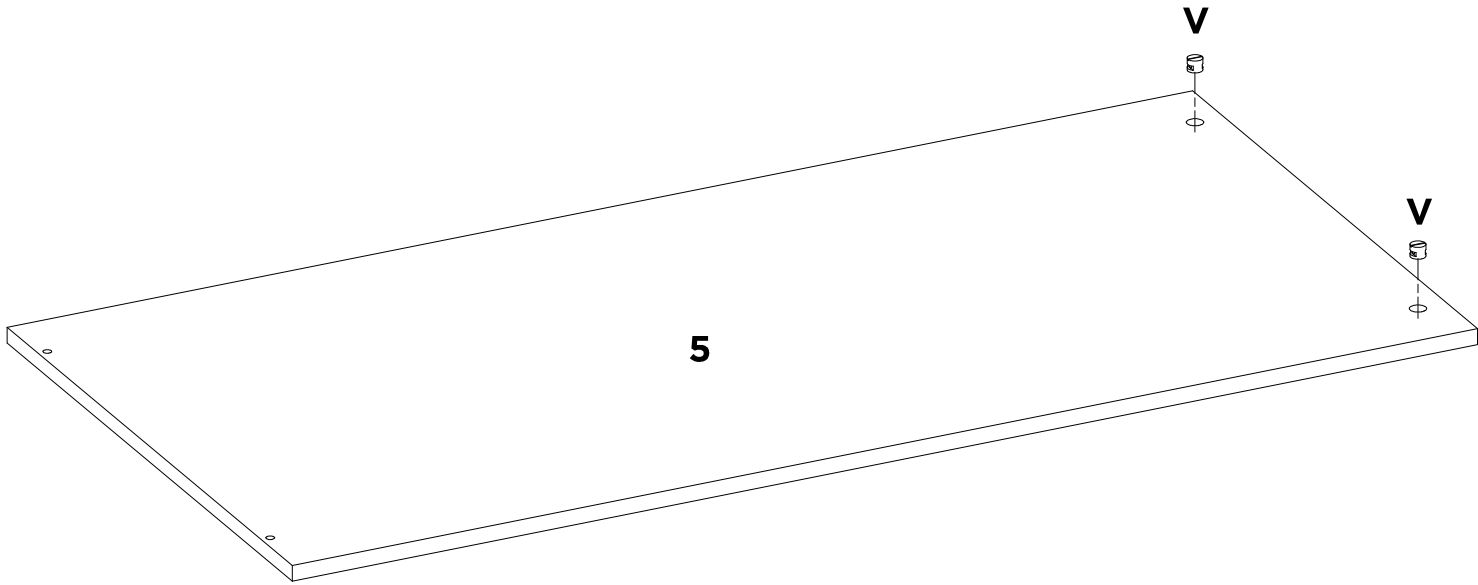

V	-	-	-	-	-	-	-
X2	-	-	-	-	-	-	-

15

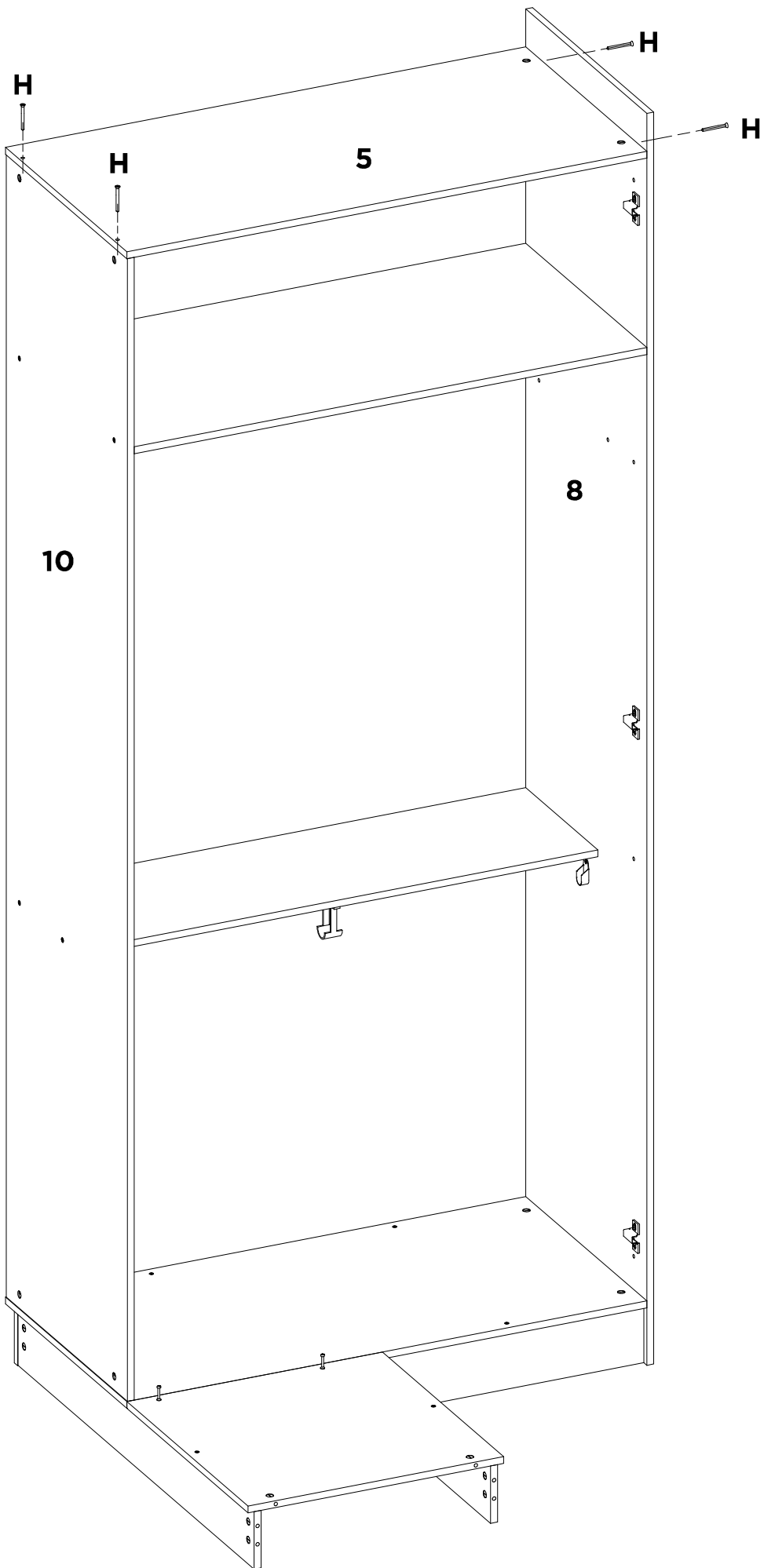

H	-	-	-	-	-	-	-
X4	-	-	-	-	-	-	-

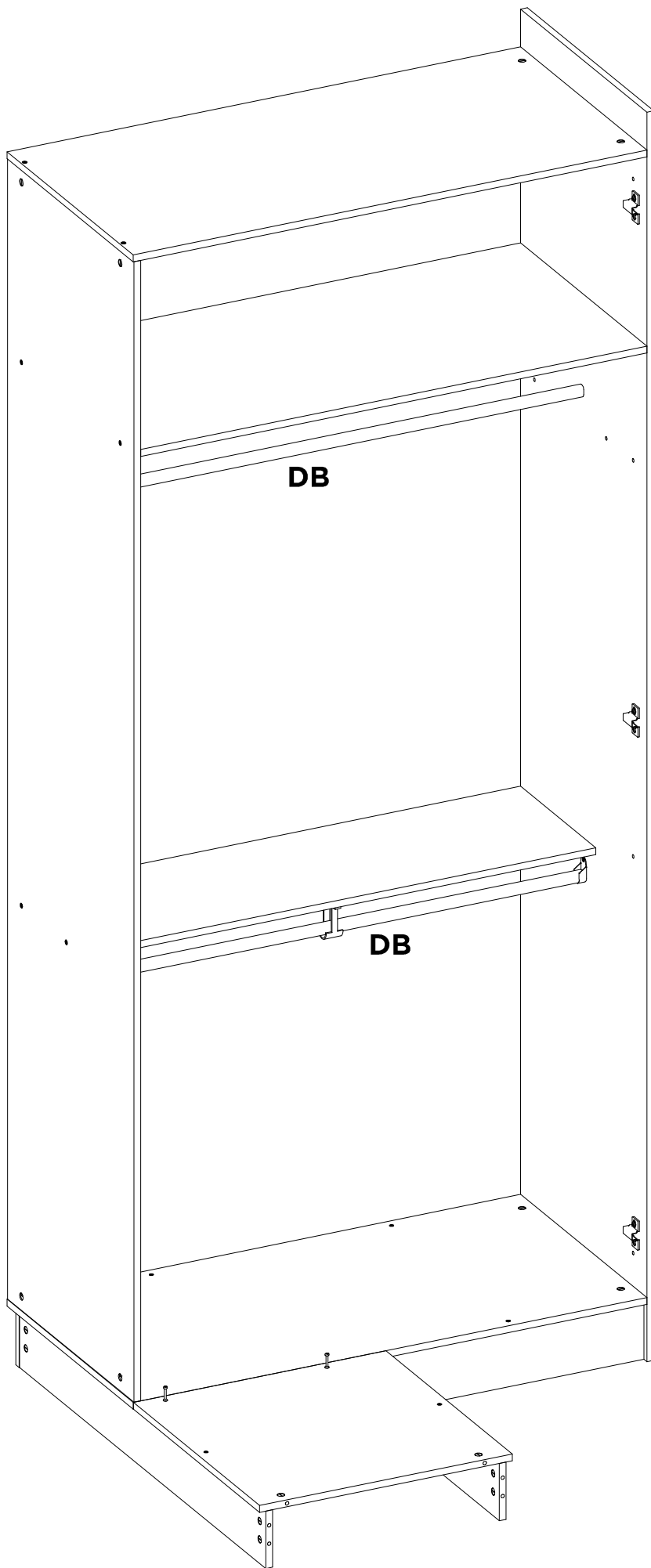

DB	-	-	-	-	-	-	-
X2	-	-	-	-	-	-	-

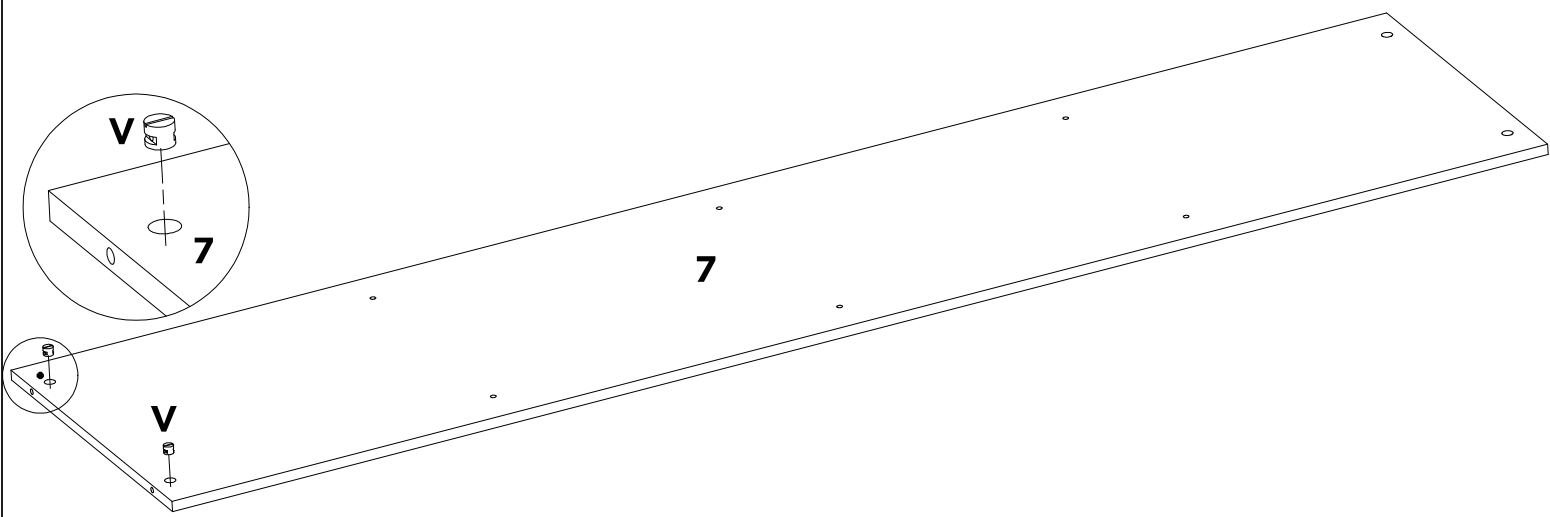

V	-	-	-	-	-	-	-
X2	-	-	-	-	-	-	-

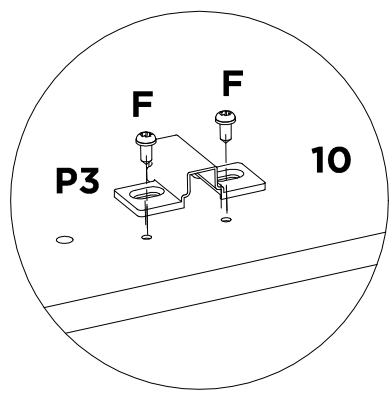
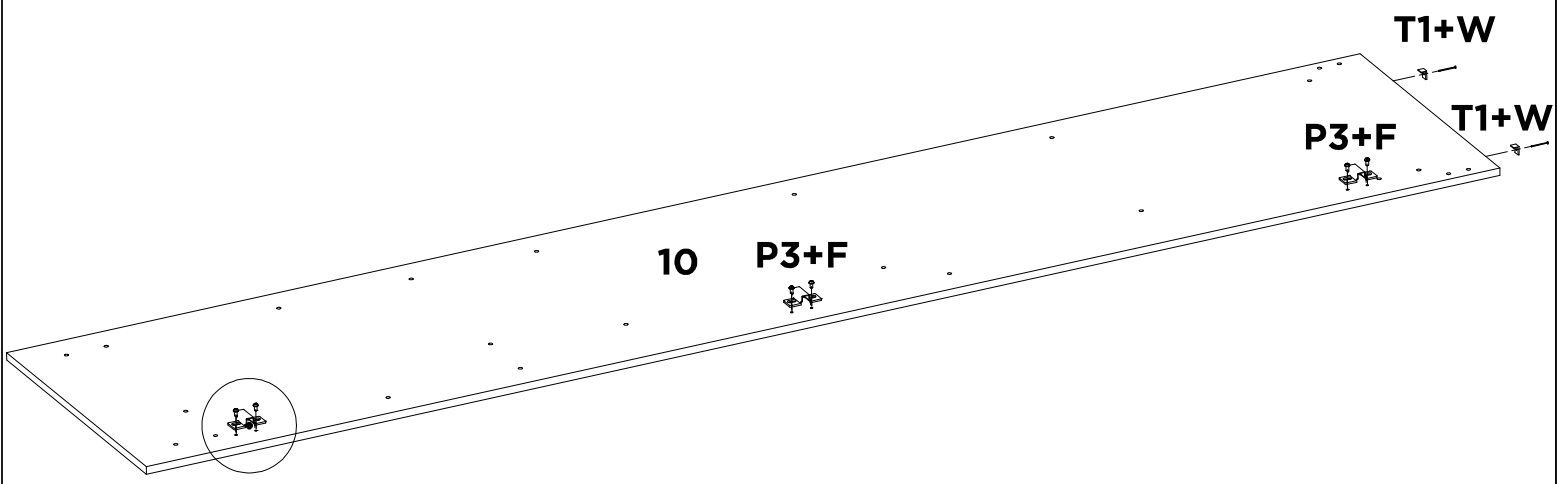

P3	F	T1	W	-	-	-	-
X3	X6	X2	X2	-	-	-	-

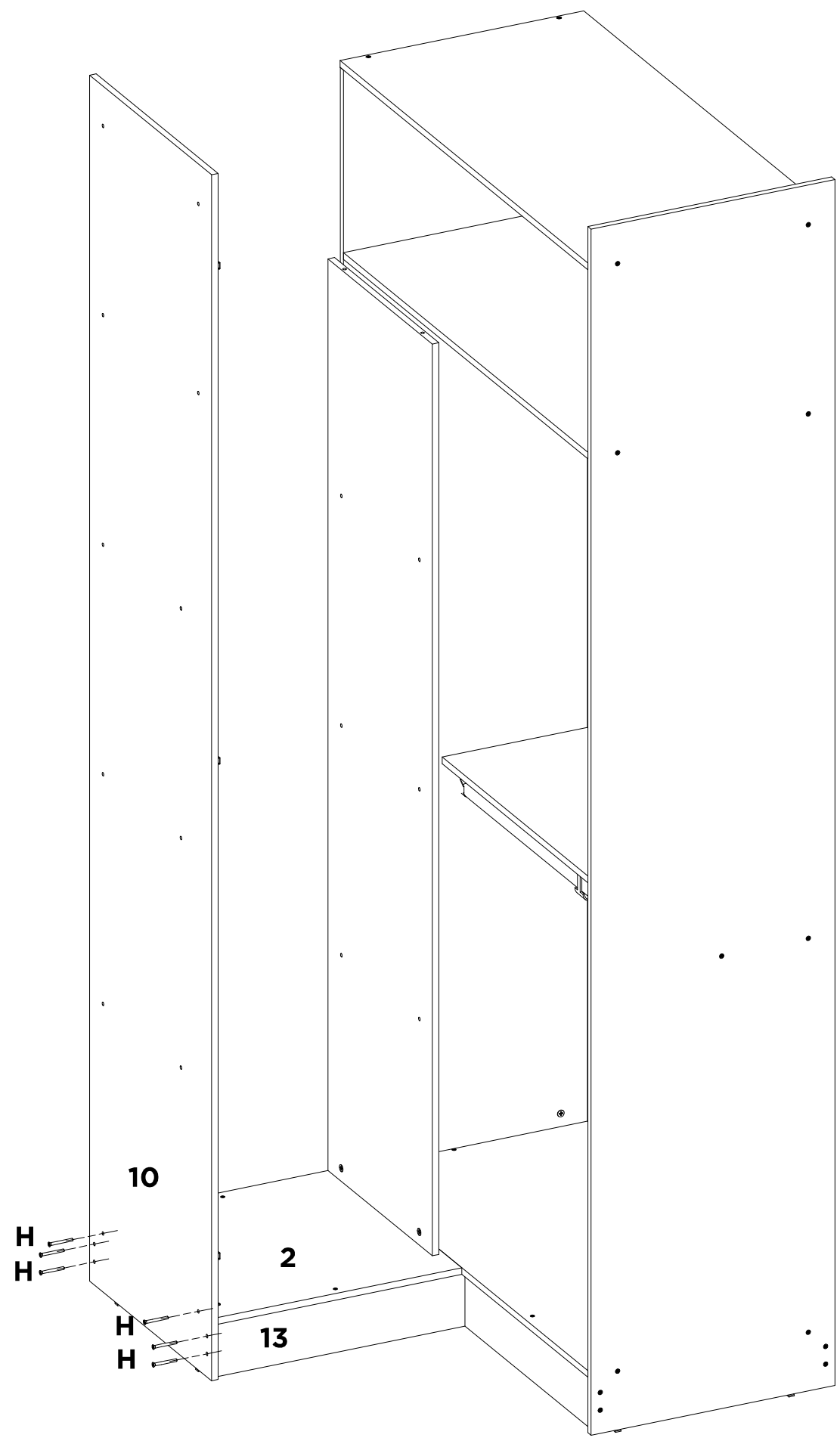

H	-	-	-	-	-	-	-
X6	-	-	-	-	-	-	-

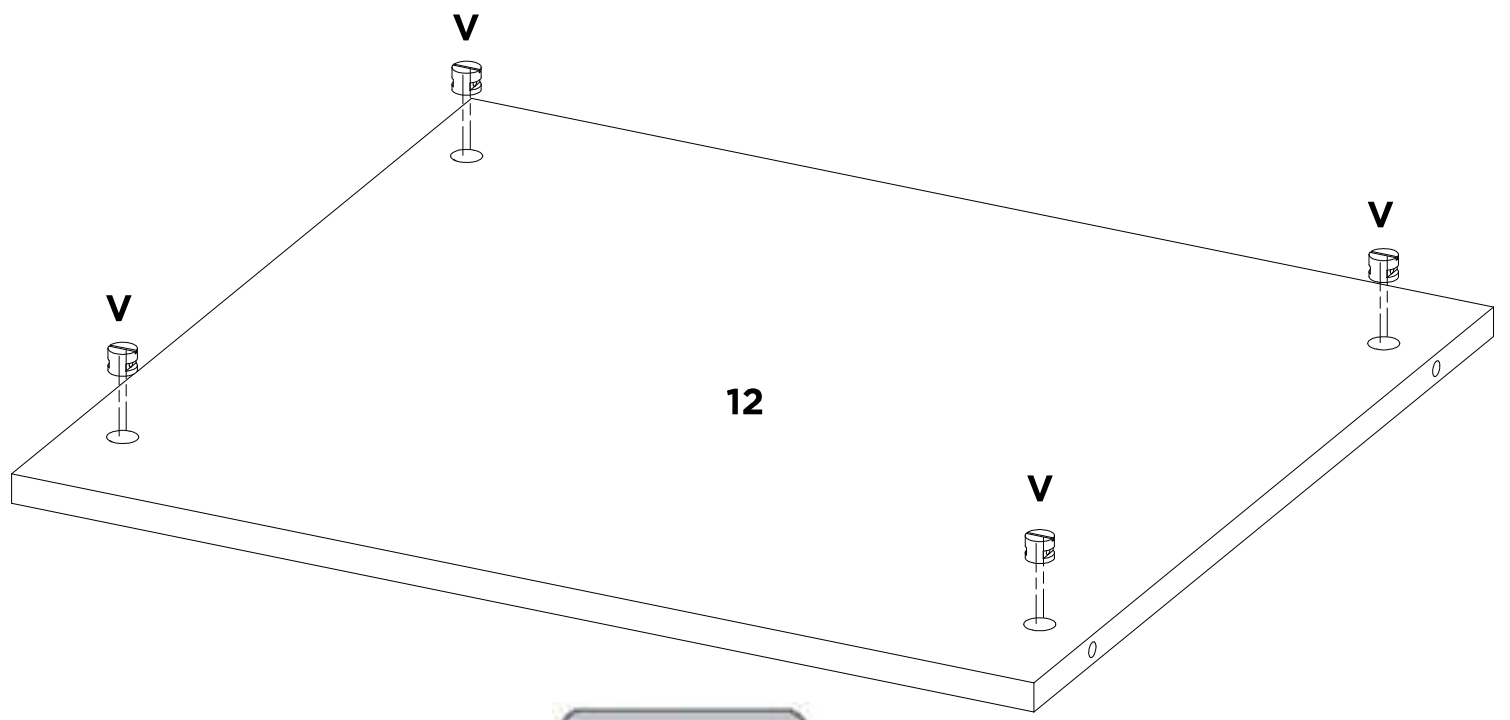

3x

V	-	-	-	-	-	-	-
X12	-	-	-	-	-	-	-

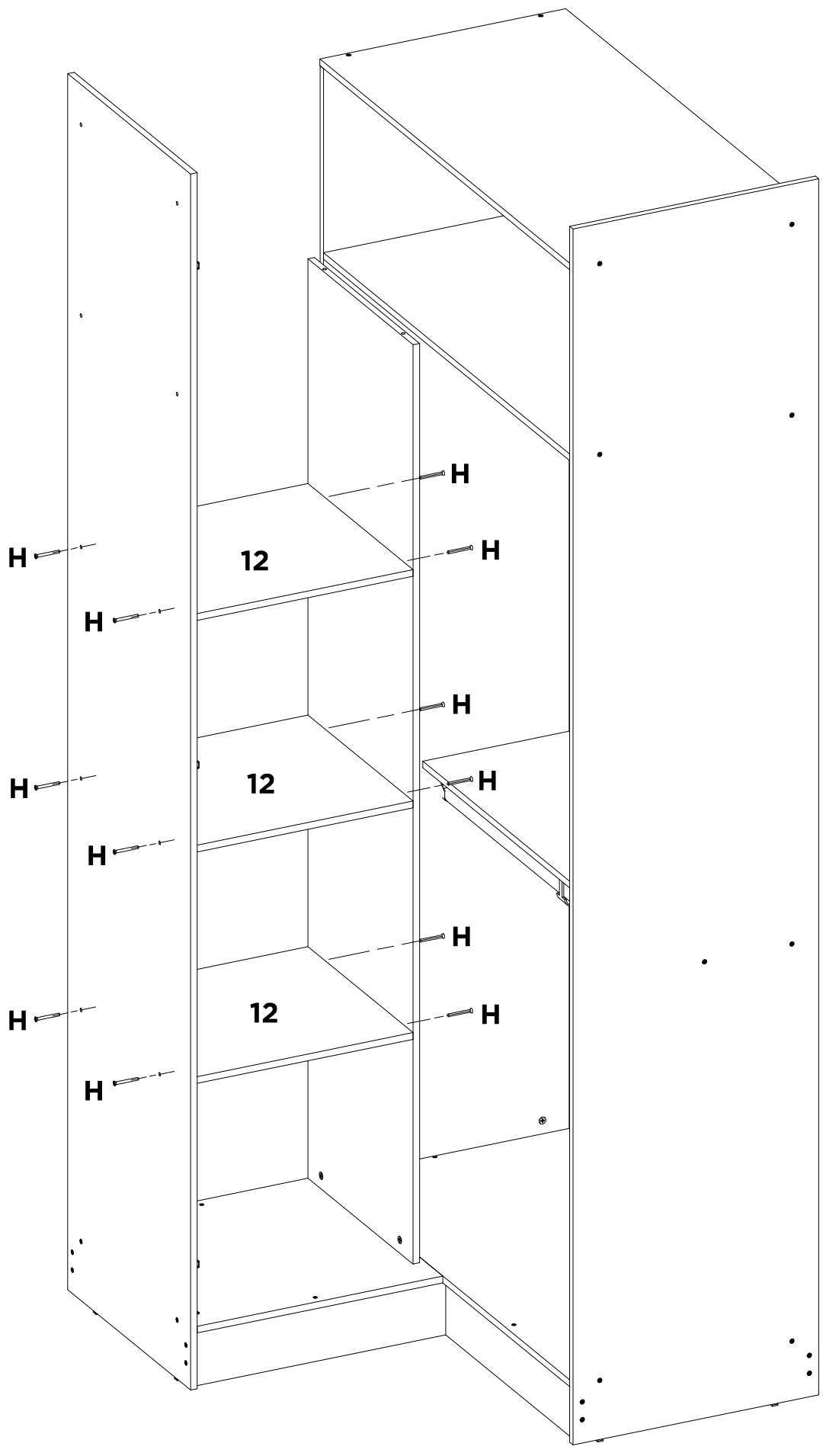

H	-	-	-	-	-	-	-
X12	-	-	-	-	-	-	-

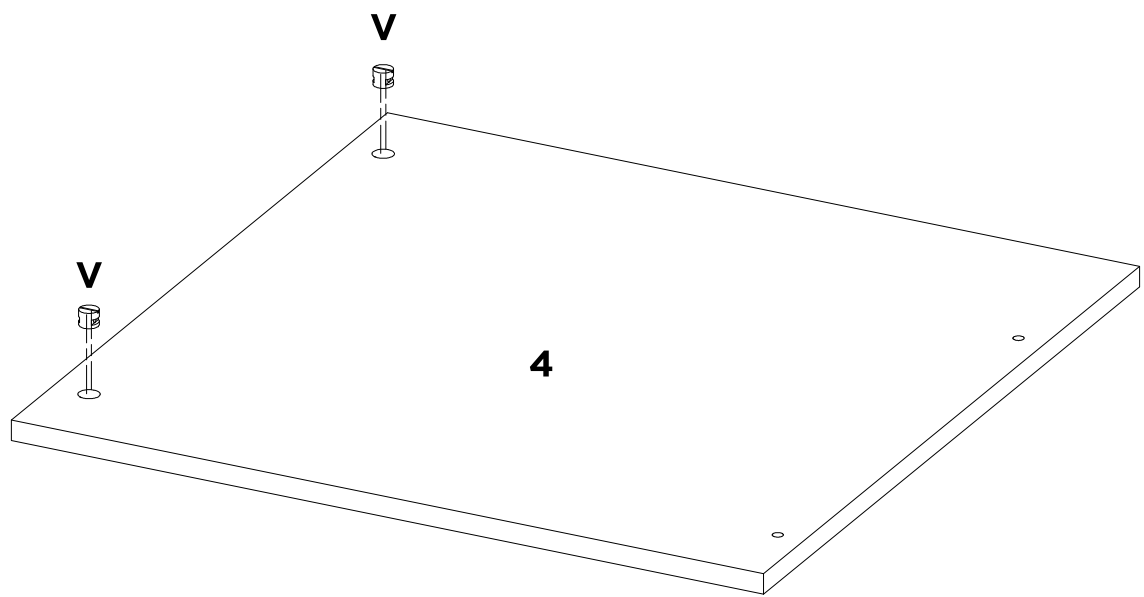

V	-	-	-	-	-	-	-
X2	-	-	-	-	-	-	-

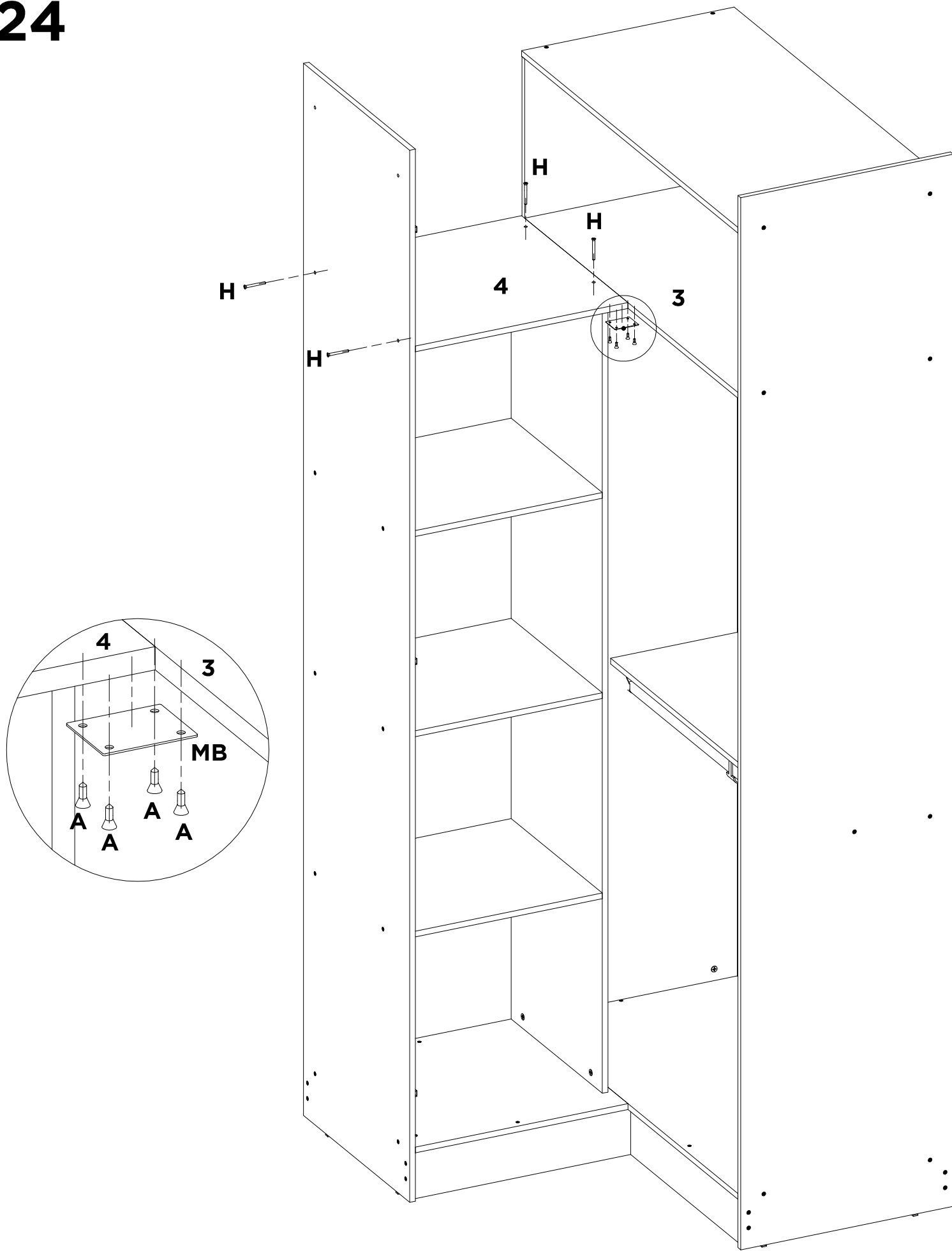

H	M2	A	-	-	-	-	-
X4	X2	X8	-	-	-	-	-

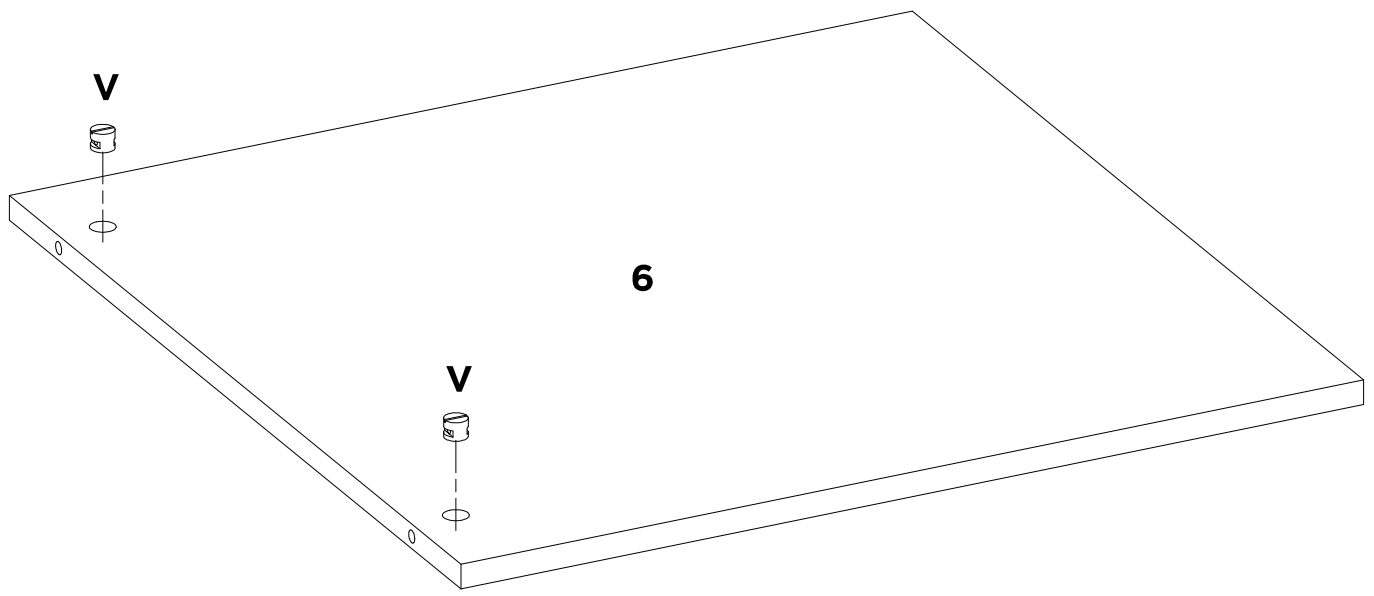

V	-	-	-	-	-	-	-
X2	-	-	-	-	-	-	-

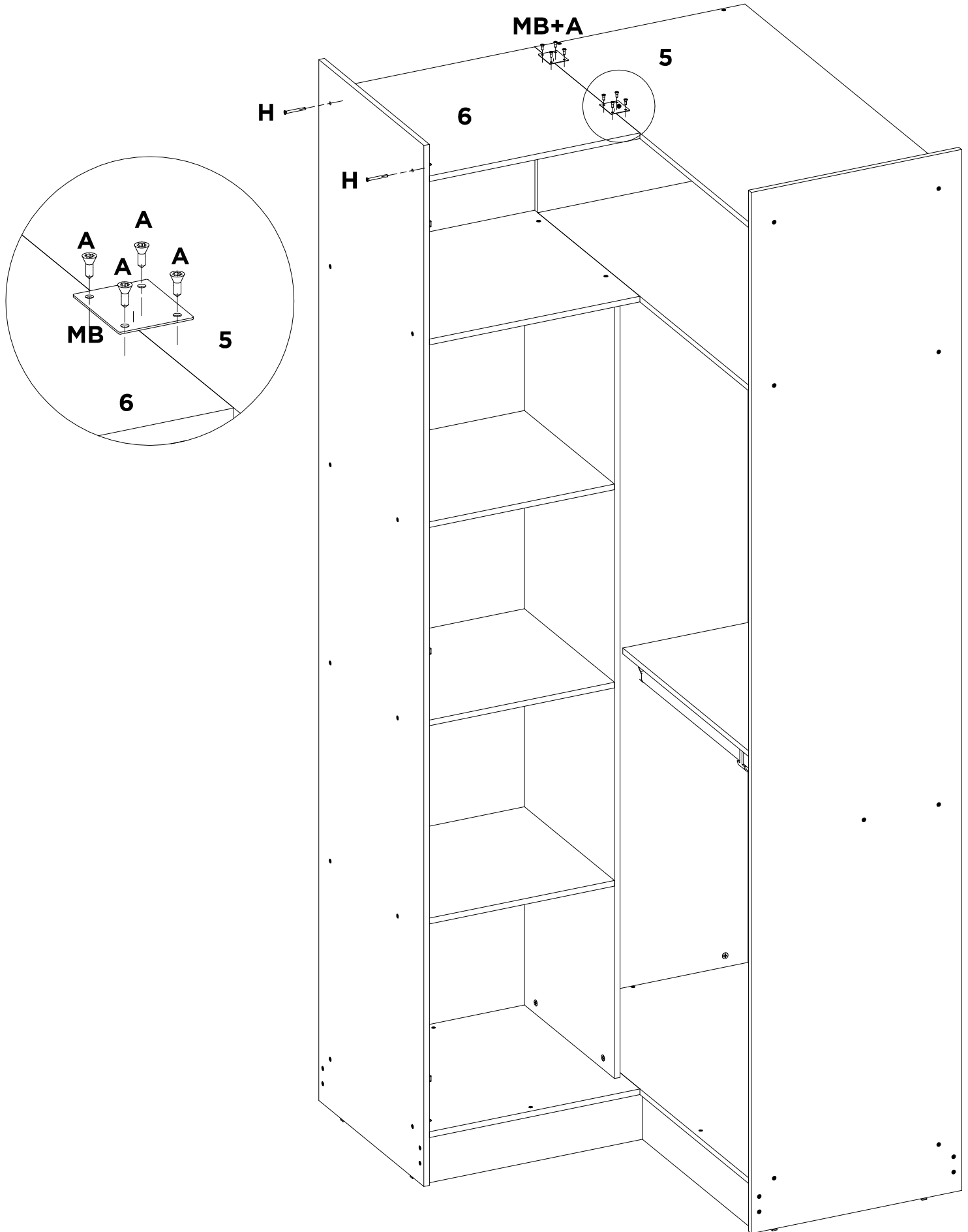

H	MB	A	-	-	-	-	-
X2	X2	X8	-	-	-	-	-

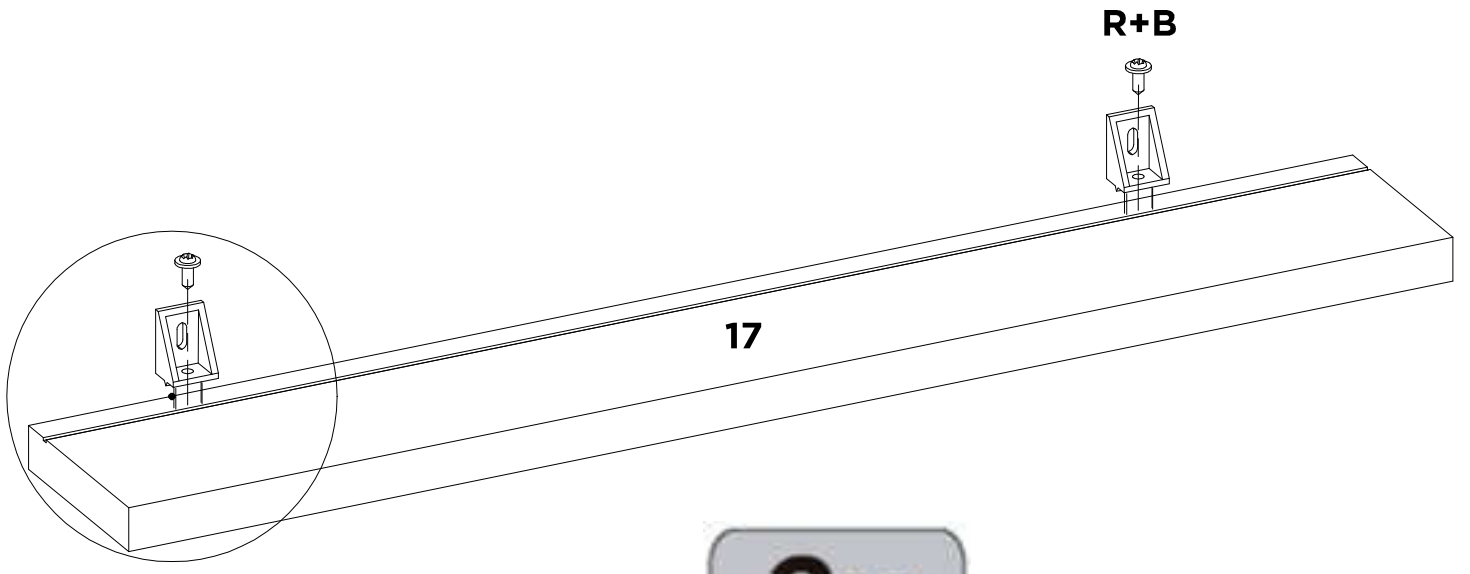
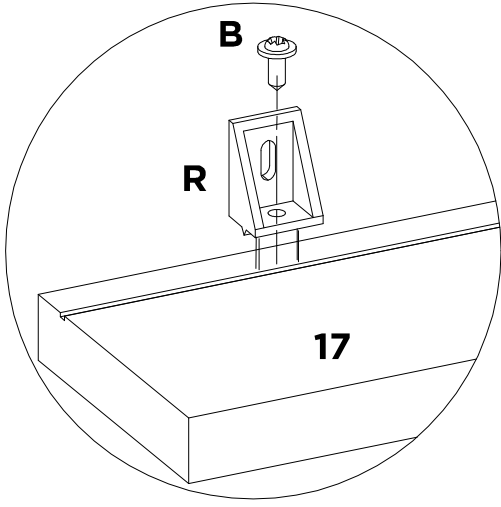

2x

R	B	-	-	-	-	-	-
X4	X4	-	-	-	-	-	-

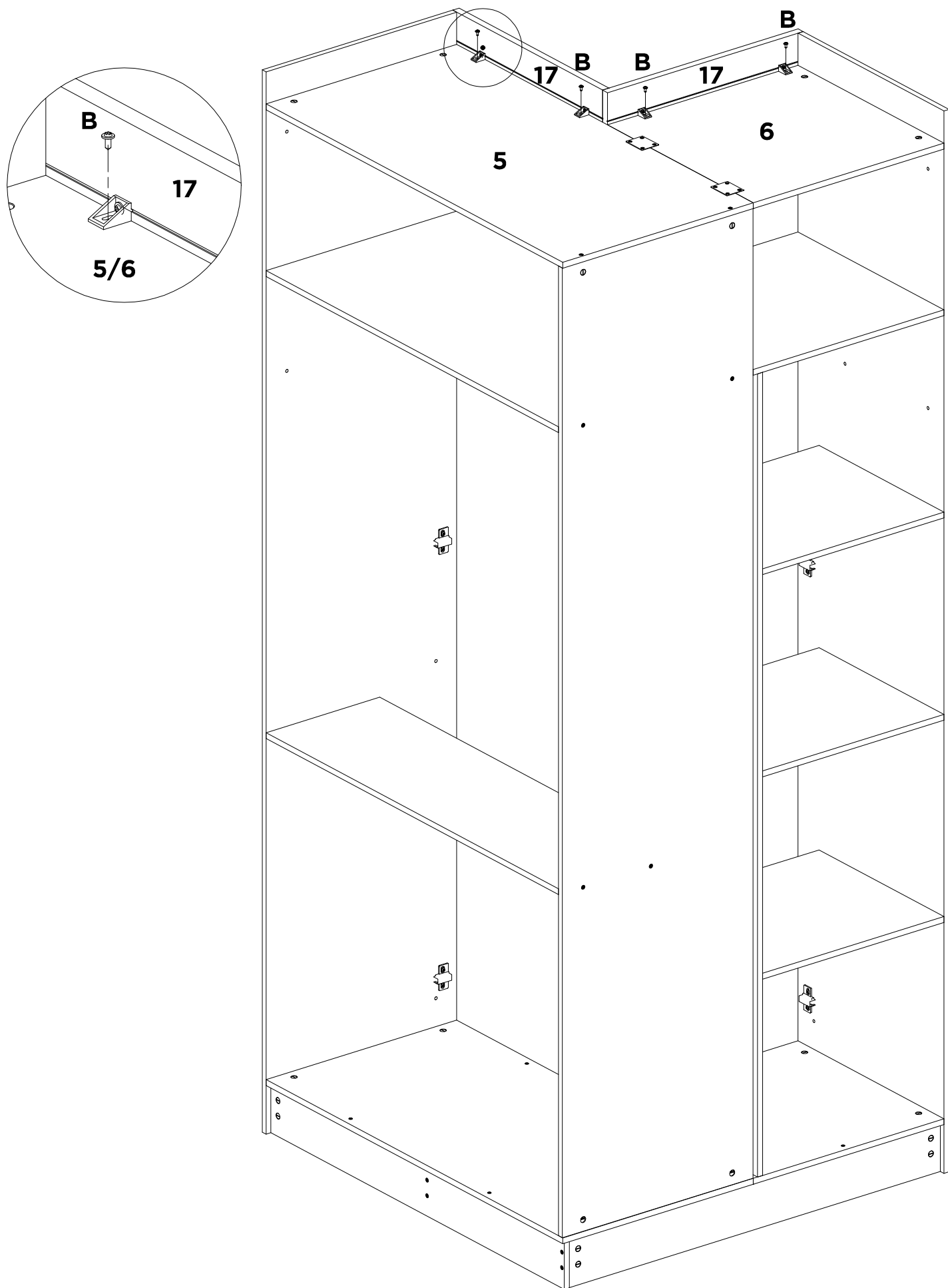

B	-	-	-	-	-	-	-	-
X4	-	-	-	-	-	-	-	-

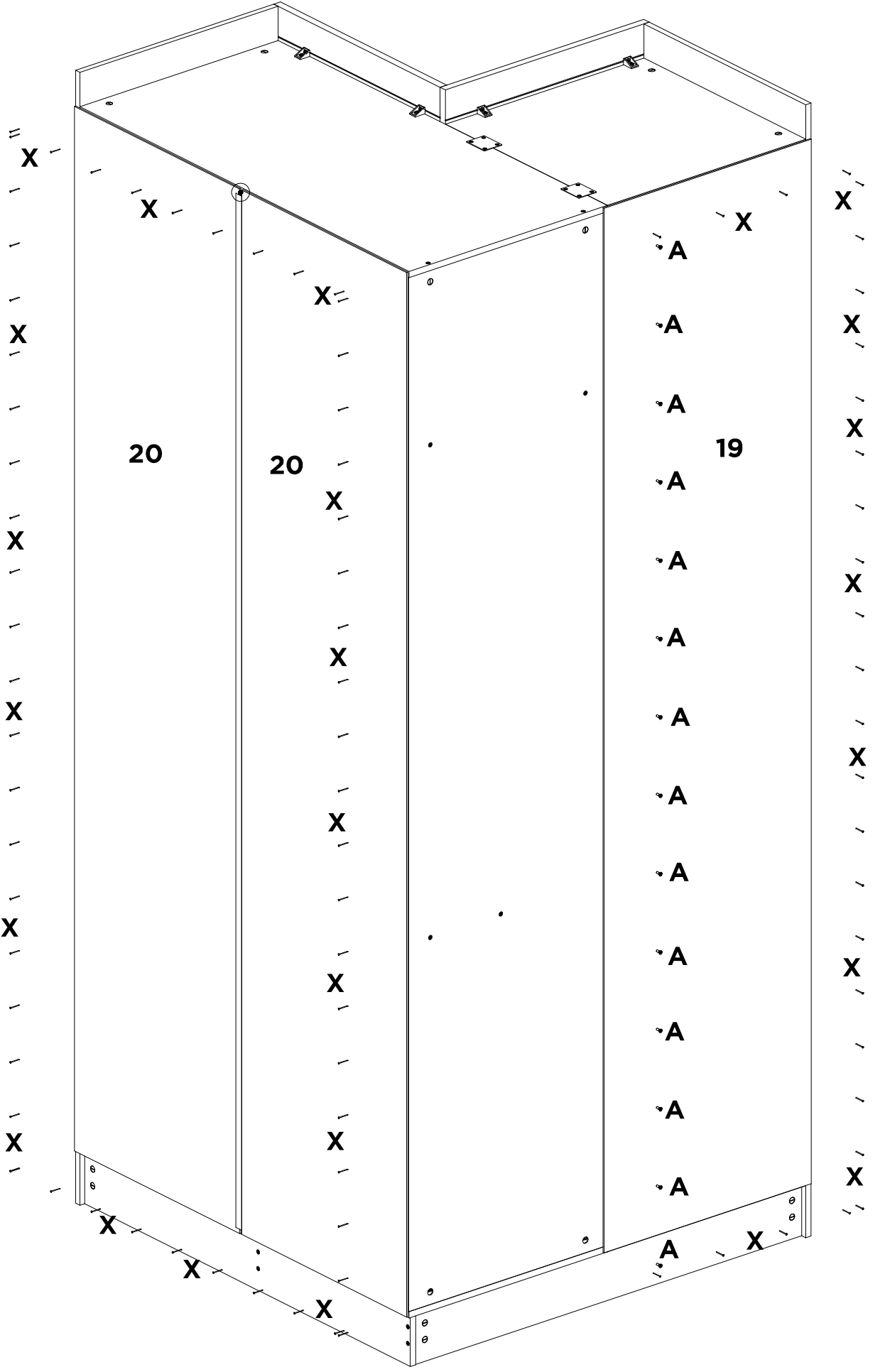
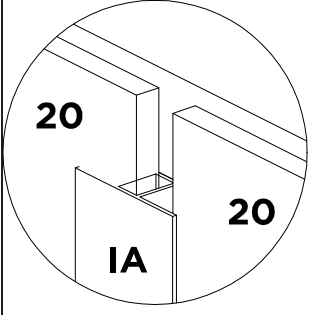

X	IA	A	-	-	-	-	-
130	X1	X14	-	-	-	-	-

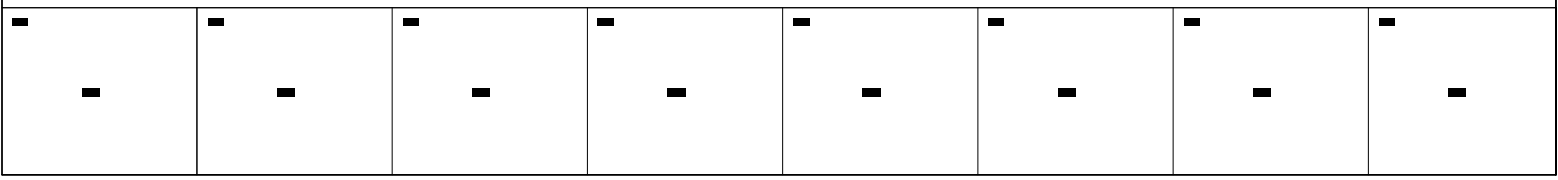
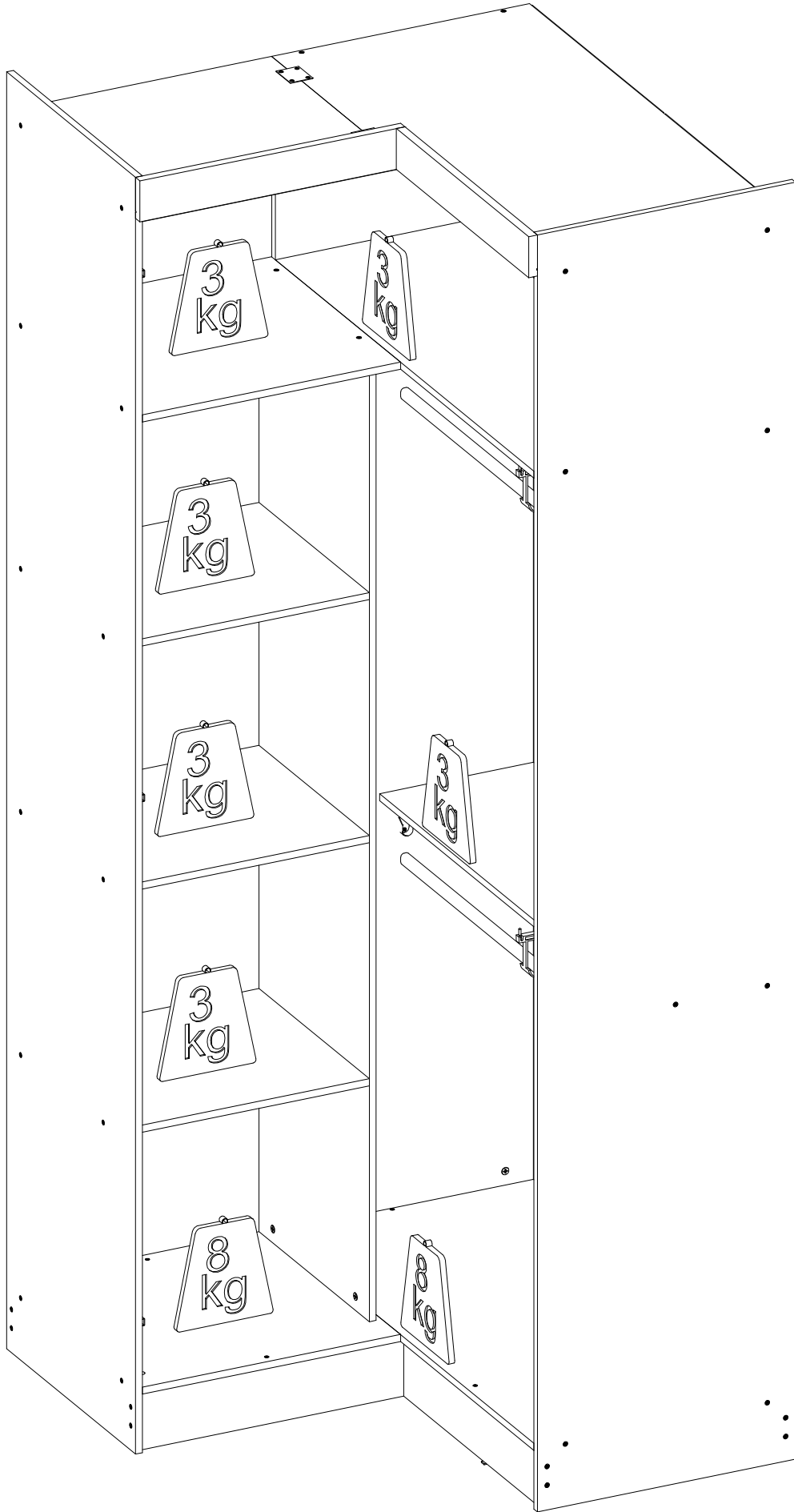

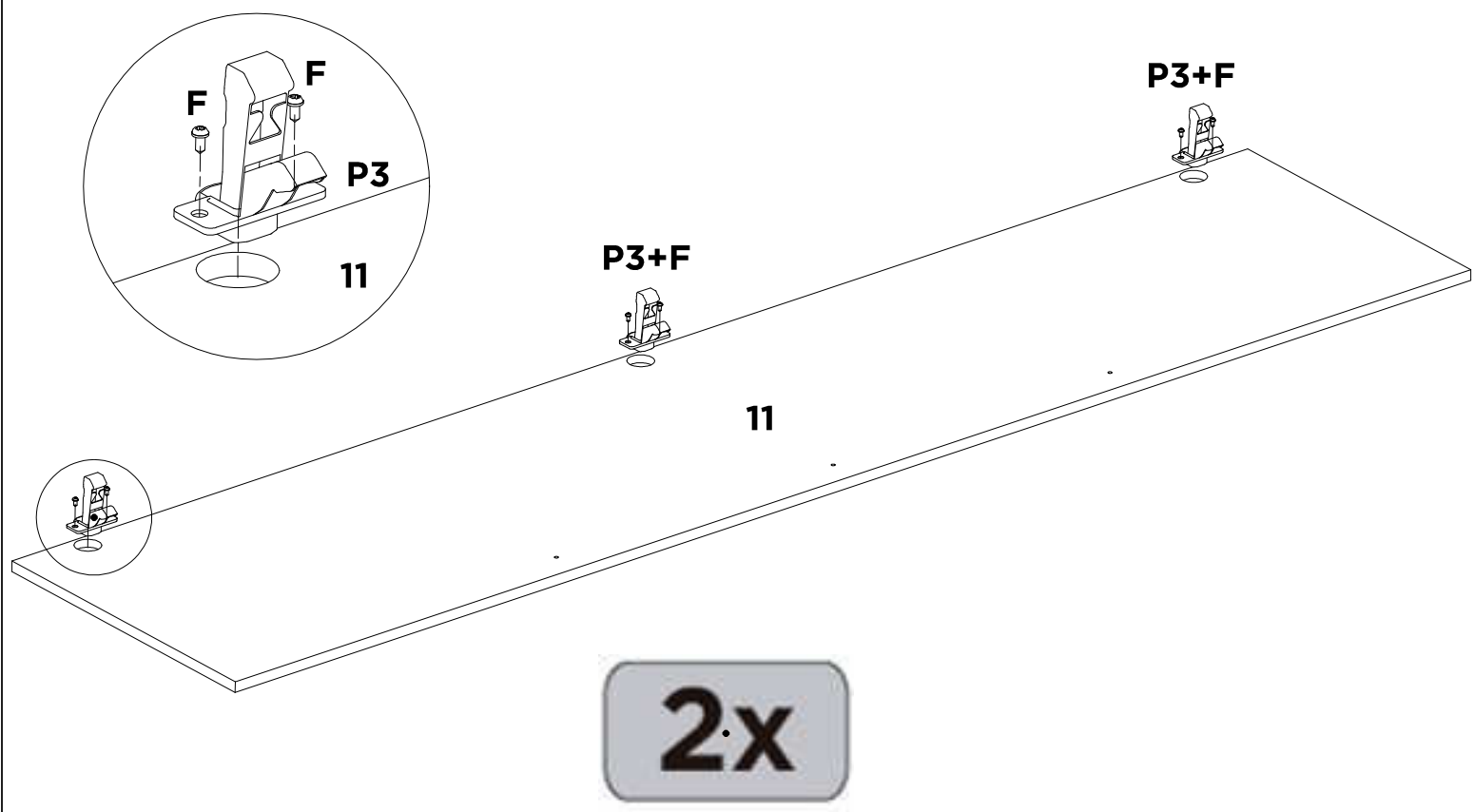

P3	F	-	-	-	-	-	-
X6	X12	-	-	-	-	-	-

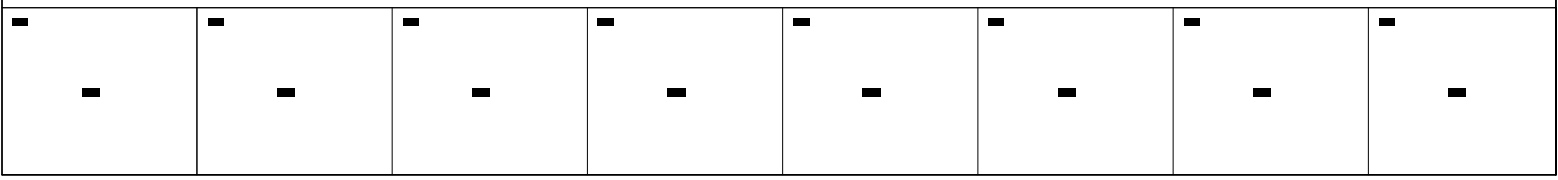
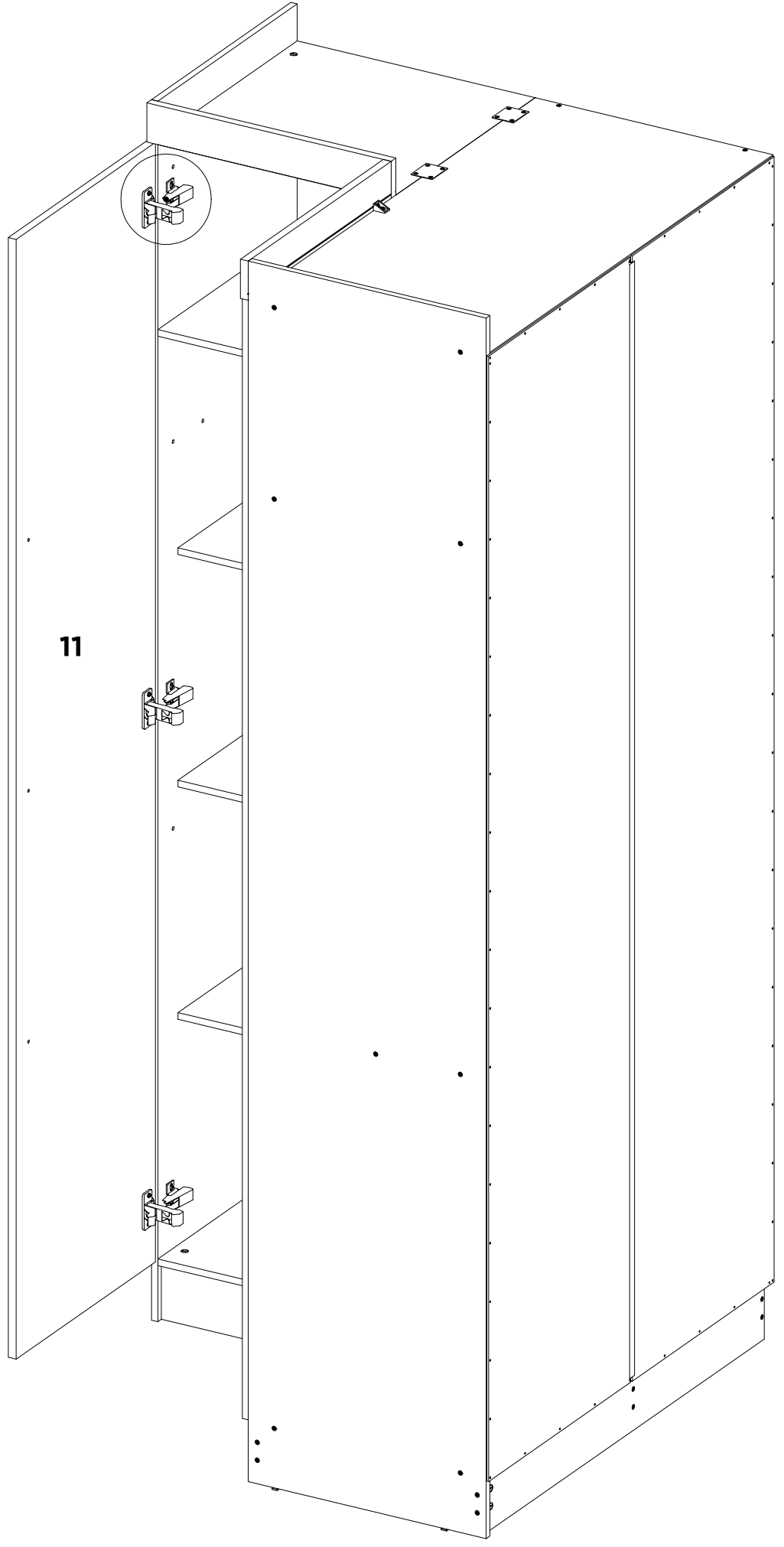
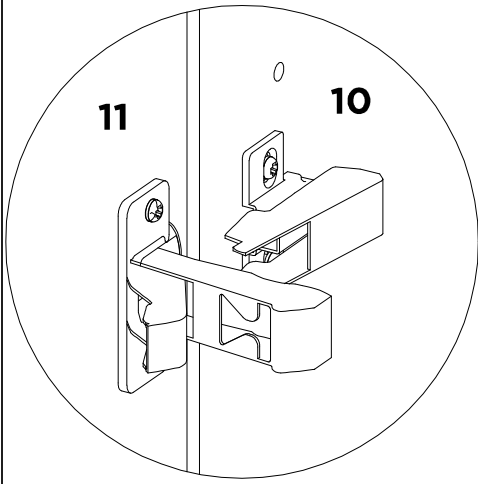

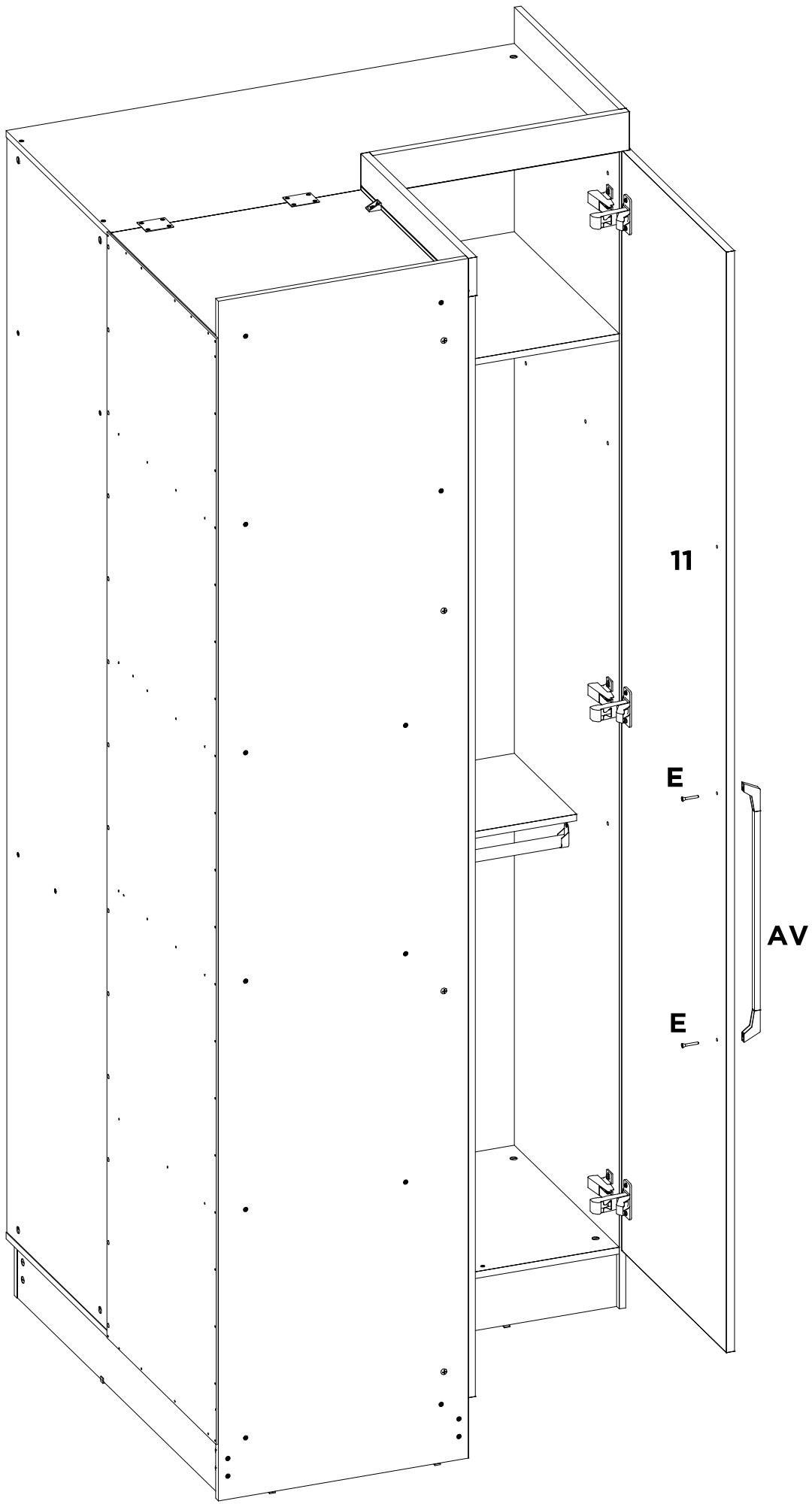

E	AV	TB	A6	-	-	-	-
X2	X2	X1	X4	-	-	-	-

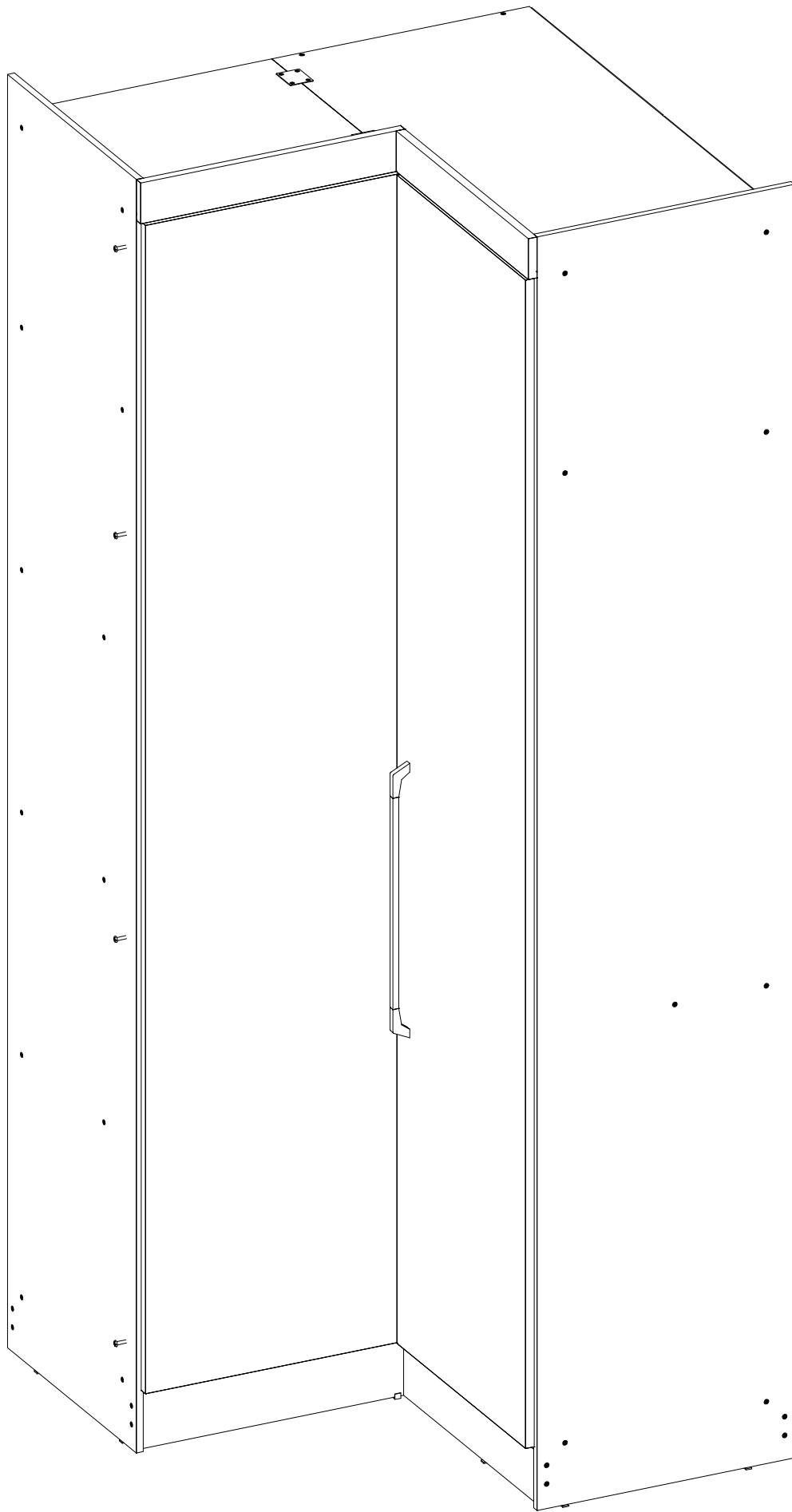

■	■	■	■	■	■	■	■
■	■	■	■	■	■	■	■



DEMÓBILE