



**DEMÓBILE**



**32860 GUARDA ROUPA 03 PORTAS 02 GAVETAS WIND**

**32860 WARDROBE 03 DOORS 02 DRAWERS WIND**

**32860 CLOSET 04 PUERTAS 02 CAJONES WIND**

32860

**GUARDA ROUPA 03 PORTAS 02 GAVETAS WIND  
WARDROBE 03 DOORS 02 DRAWERS WIND  
CLOSET 04 PUERTAS 02 CAJONES WIND**

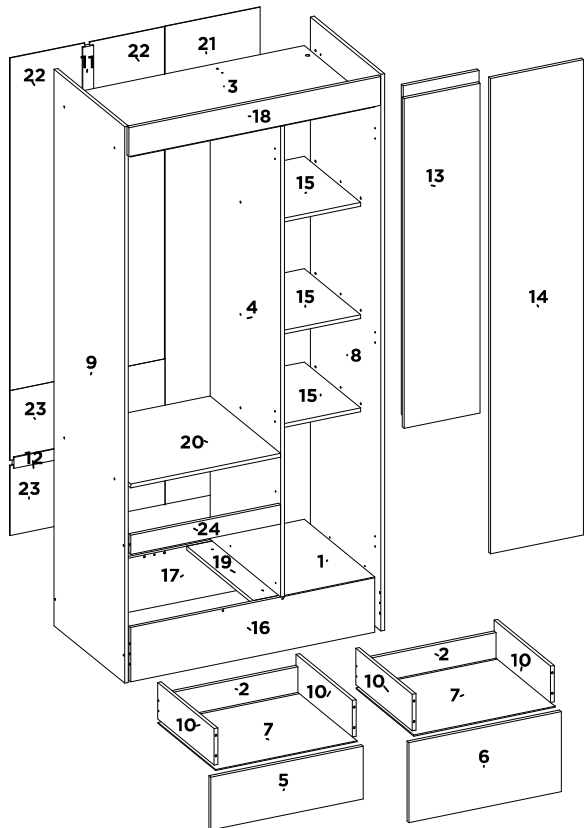

SEQ.	CODIGO	REF_01	REF_02	REF_03	REF_04	REF_05	REF_06	REF_07	DESCRICAO	DESCRIPTION_EN	DESCRIPCION_ES	DIMENSÕES_MM	QTD.
1	03099	03	113	112	138	138	-	-	BASE	BASE	BASE	450 X 288 X 3	1
2	06068	03	113	112	138	138	-	-	CONTRA FUNDO	DRAWER BACK	CONTRA FONDO	429 X 80 X 12	2
3	07084	03	113	112	138	138	-	-	CHAPEU	TOP PANEL	TAPA SUPERIOR DEL ROPERO	778 X 450 X 12	1
4	08202	03	113	112	138	138	-	-	DIVISAO	RIGHT DIVISION	DIVISION DERECHA	1472 X 450 X 12	1
5	09121	03	108	105	140	134	-	-	FRENTE DE GAVETA MENOR	DRAWER FRONT	FRENTE DEL CAJON	486 X 165 X 12	1
6	09122	03	108	105	140	134	-	-	FRENTE DE GAVETA MAIOR	DRAWER FRONT	FRENTE DEL CAJON	486 X 250 X 12	1
7	10004	03	113	112	138	138	-	-	FUNDO GAVETA	DRAWER BASE	FONDO DEL CAJON	451 X 368 X 3	2
8	11250	03	106	110	136	136	-	-	LATERAL DIREITA	RIGHT SIDE PANEL	LATERAL DERECHA	1740 X 450 X 12	1
9	11643	03	111	110	136	136	-	-	LATERAL ESQUERDA	LEFT SIDE PANEL	LATERAL IZQUIERDA	1740 X 450 X 12	1
10	12004	03	113	112	138	138	-	-	LATERAL DE GAVETA	DRAWER SIDE	LATERAL DEL CAJON	360 X 114 X 12	4
11	13025	03	113	112	138	138	-	-	PERFIL H 35MM 1023 X 35 X 12 MM	PROFILE H	PERFIL H	1023 X 35 X 12	1
12	13032	20	20	20	20	20	-	-	PERFIL H 35MM 478 X 35 X 12 MM	PROFILE H	PERFIL H	478 X 35 X 12	1
13	14199	03	108	105	140	134	-	-	PORTA PEQUENA	DOOR	PUERTA	1031 X 242 X 12	2
14	14213	03	108	105	140	134	-	-	PORTA GRANDE	DOOR	PUERTA	1486 X 296 X 12	1
15	15112	03	113	112	138	138	-	-	PRATELEIRA	SHELF	ESTANTERIA	360 X 288 X 12	3
16	16250	03	111	110	134	134	-	-	RODAPE FRONTAL	BOTTOM BOARD FRONT	ZÓCALO FRONTAL	778 X 170 X 12	1
17	16251	20	20	20	20	20	-	-	RODAPE TRASEIRO	BOTTOM BOARD BACK	ZÓCALO TRASEIRO	778 X 170 X 12	1
18	17071	19	106	105	134	134	-	-	RODATETO	TOP FRONT BOARD	MOLDURA SUPERIOR	802 X 90 X 12	1
19	18009	20	20	20	20	20	-	-	SUPORTE DA BASE	BASE SUPPORT	SOPORTE DE BASE	425 X 110 X 12	1
20	19168	03	113	112	138	138	-	-	TAMPO GAVETEIRO	DRAWER CABINET TOP PANEL	TAPA DEL CAJÓN	478 X 450 X 12	1
21	20272	03	113	112	138	138	-	-	TRASEIRO LATERAL	BACK PANEL	TRASERO	1494 X 303 X 3	1
22	20273	03	113	112	138	138	-	-	TRASEIRO	BACK PANEL	TRASERO	1039 X 238 X 3	2
23	20274	20	20	20	20	20	-	-	TRASEIRO GAVETEIRO	BACK PANEL	TRASERO	494 X 219 X 3	2
24	29051	19	111	110	136	136	-	-	VISTA DA GAVETA	FRONT CRANKCASE	TRAVESA FRONTAL	478 X 60 X 12	1

**DEMÓBILE** Indústria de Móveis Ltda.  
Rua : Jurutau, 1350 - Pq. Industrial II.  
Cep.: 96703-070  
Aragongas - PR - Brasil  
demobile@demobile.com.br

**90 DIAS GARANTIA**

- Avisos**
1. Ler atentamente as instruções do manual antes de iniciar a montagem do móvel.
  2. A montagem deverá ser feita em superfície limpa e plana, aconselhamos forrar o chão com a embalagem do produto, para não danificar.
  3. Os parafusos devem ser apertados periodicamente.
  4. Evitar batidas e contato com objetos cortantes.
  5. O peso máximo de carga informado refere-se a objetos distribuídos de maneira uniforme sobre toda área de contato da peça.
- Limpeza e Conservação**  
Efetuar a limpeza somente com pano macio limpo e seco.  
Não Utilizar produtos abrasivos ou químicos.
- Garantia**  
1.O fabricante responsabiliza-se apenas pelas peças do produto.  
2.A montagem incorreta acarretará na perda da garantia e das assistências, desta forma o produto deverá ser montado por profissional qualificado.  
3.Não estão cobertos pela garantia problemas que tenham origem na utilização inadequada do produto ou na exposição do mesmo a intempéries como: infiltrações, infestação de pragas em geral, aparecimento de mofo e outros, decorrentes do ambiente de instalação.

Assistência Técnica: Em caso de peças em assistência técnica é necessário que as mesmas sejam solicitadas junto a loja ou site no qual a compra do produto foi realizada.

- Warnings**
1. Read the manual instructions carefully before starting to assemble the furniture.
  2. The assembly must be done in clean and flat surface, we advise to put the product packaging on the floor, not to damage it during the assembling.
  3. The screws must be tightened periodically.
  4. Avoid hitting and contacting sharp objects.
  5. The payload informed refers to the objects distributed all over the piece contact area.
- Cleaning and conservation**  
Clean the product just with a soft, cleaned and dry cloth.  
Do not use abrasive or chemicals products.
- Warranty**  
1.The manufacturer is only responsible for product parts.  
2. Incorrect assembling will make you lost the guarantee and assistance, in this way the product must be assembled by qualified professional.  
3. It is Not covered by the warranty problems caused by an inappropriate use of the product or product exposure even in bad weather, such as: infiltrations, pest infestation in general, appearance of mold and others, caused by the installation environment.

Technical Assistance: Damaged pieces! Ask on the stores you bought it.

- Advertencias**
1. Lee atentamente las instrucciones del manual antes de empezar a armar los muebles.
  2. El montaje debe hacerse en superficie limpia y plana, utilice el empaque del Producto para cubrir el piso.
  3. Los tornillos deben ser apretados periodicamente
  4. Evite golpear y chocar objetos punzantes
  5. El peso máximo de carga tiene relación a los objetos distribuidos sobre toda el área de contacto de la pieza.
- Limpeza y conservación**  
Limpiar solo con un trapo suave, limpio y seco  
No utilice productos abrasivos o productos químicos

Garantía  
1.El fabricante solo es responsable a las partes del producto.  
2. Armar incorrectamente supone la pérdida de garantía y repuestos, de esta manera el producto debe ser ensamblado por profesional calificado.  
3.No es garantizado problemas derivados del uso inapropiado del producto, o exposición del producto al mal tiempo, como: infiltraciones, infestación de plagas en general, aparición de moho y otros.

Assistência técnica: em caso de peças rotas es necesario que sea solicitadas las mismas a la tienda o sitio web donde se compró el producto.

**COMPLETE MANUAL**

**MANUAL COMPLETO**

**Acessórios/Accessories/Acessorios**

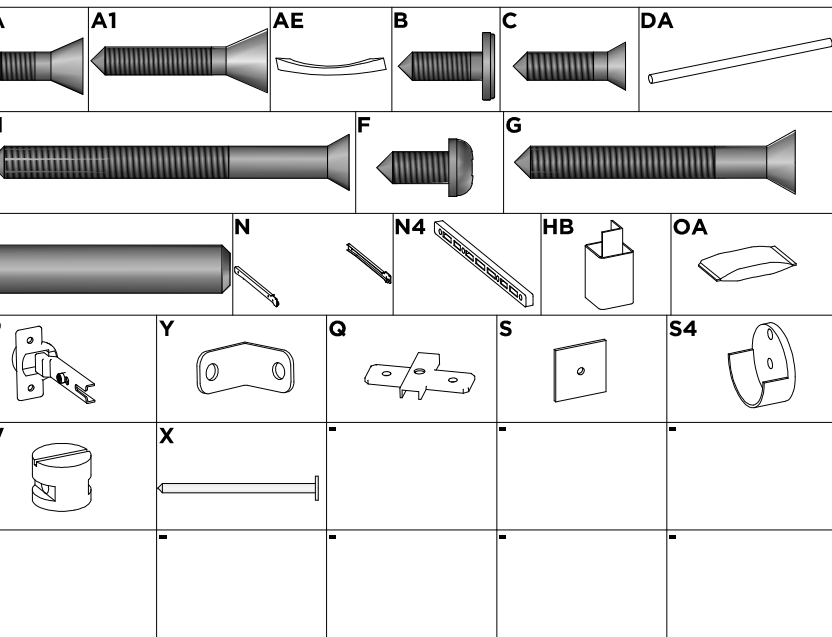

**LISTA DE AÇESSÓRIOS / LIST OF ACCESSORIES / LISTA DE ACCESORIOS**

SEQ.	CODIGO	DESCRIÇÃO	DESCRIPTION_EN	DESCRIPCION_ES	QTD.
A	9905002	PARAFUSO 3.5 X 12 MM CHATA PHILIPS	PHILIPS FLAT HEAD SCREW	TORNILLO CHATA PHILIPS	36
A1	9905023	PARAFUSO 3.5 X 22 MM CHATA PHILIPS	PHILIPS FLAT HEAD SCREW	TORNILLO CHATA PHILIPS	14
AE	9904021	PUXADOR ALPHA F 128 MM PRATA	HANDLE	TIRADOR	3
B	9905003	PARAFUSO 3.5 X 12 MM FLANGEADO PHILIPS	PHILIPS FLANGE SCREW	TORNILLO DE BRIDA PHILIPS	16
C	9905046	PARAFUSO 3.5 X 14 MM CHATA PHILIPS	PHILIPS FLAT HEAD SCREW	TORNILLO CHATA PHILIPS	18
DA	9901027	CABIDEIRO REDONDO 470 MM MADEIRA	HANGER	PERCHERO	1
F	9905007	PARAFUSO 4 X 12 MM PANELA PHILIPS	PANHEAD SCREW	TORNILHO CABEZEIRA DE OLHA	28
G	9905012	PARAFUSO 4 X 35 MM CHATA PHILIPS	PHILIPS FLAT HEAD SCREW	TORNILLO CHATA PHILIPS	2
H	9905045	PARAFUSO 4 X 45 MM CHATA PHILIPS	PHILIPS FLAT HEAD SCREW	TORNILLO CHATA PHILIPS	24
HB	9918006	PE 47 X 47 X 100 MM PLASTICO ECONOMICO	PLASTIC FOOT	PATA DE PLASTICO	4
L	9920011	CAVILHAS 6 X 30 MM	WOODEN PEG	CLAVIJA DE MADERA	42
N	9913018	CORREDICA 350 MM METAL LIGHT BIGFER	METAL SLIDE	RIEL METALICO	2
N4	9913007	CORREDICA 255 X 16 X 10 MM PLASTICA	PLASTIC RUMER	RIEL PLASTICO	1
OA	9912006	SACHET DE COLA 10 GRAMAS	GLUE	COLA	1
P	9920020	DOBRADICA ALTA 26 MM ESTAMPADA	HINGE	BISAGRA	7
Q	9920005	CALCO DOBRADICA 5 MM	CHOCK	CALCE	7
S	9920026	FIXADOR DE FUNDO 10 X 10 MM	BOOTOM FASTENER	FUJADOR DE FONDO	15
S4	9920037	SUPORTE CABIDEIRO MEIA CANA	HANGER SUPPORT	SOPORTE DE PERCHERO	2
V	9920030	PORCA CILINDRICA 9 X 12 MM	CYLINDRICAL NUT	TUERCA CILINDRICA	22
X	9906002	PREGO 9X9 MM	NAIL	CLAVO	70
Y	9920006	CANTONEIRA METALICA 16 MM	METAL ANGLE BRACKET	ESQUINERAS METALICAS	8

**01**

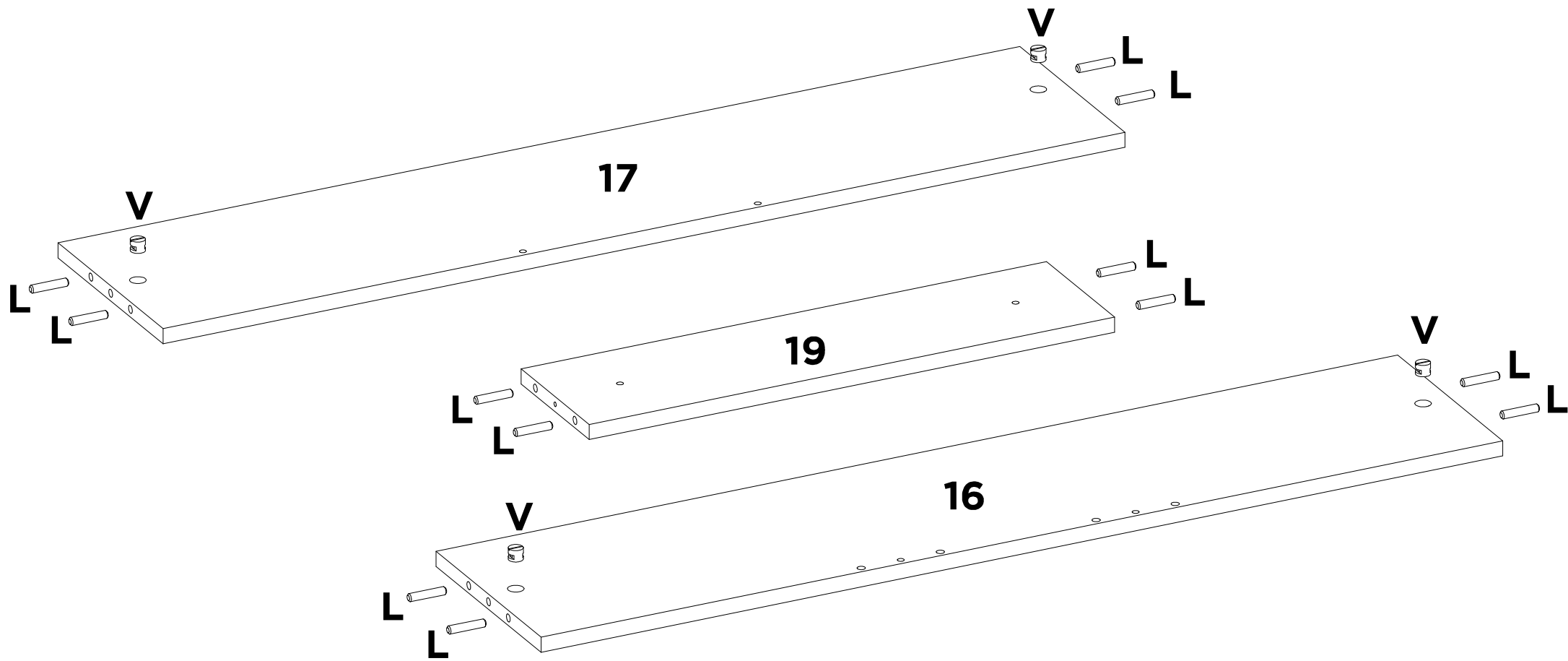

<b>L</b>	<b>X12</b>	<b>V</b>	<b>X4</b>	-	-	-	-	-	-
----------	------------	----------	-----------	---	---	---	---	---	---

02

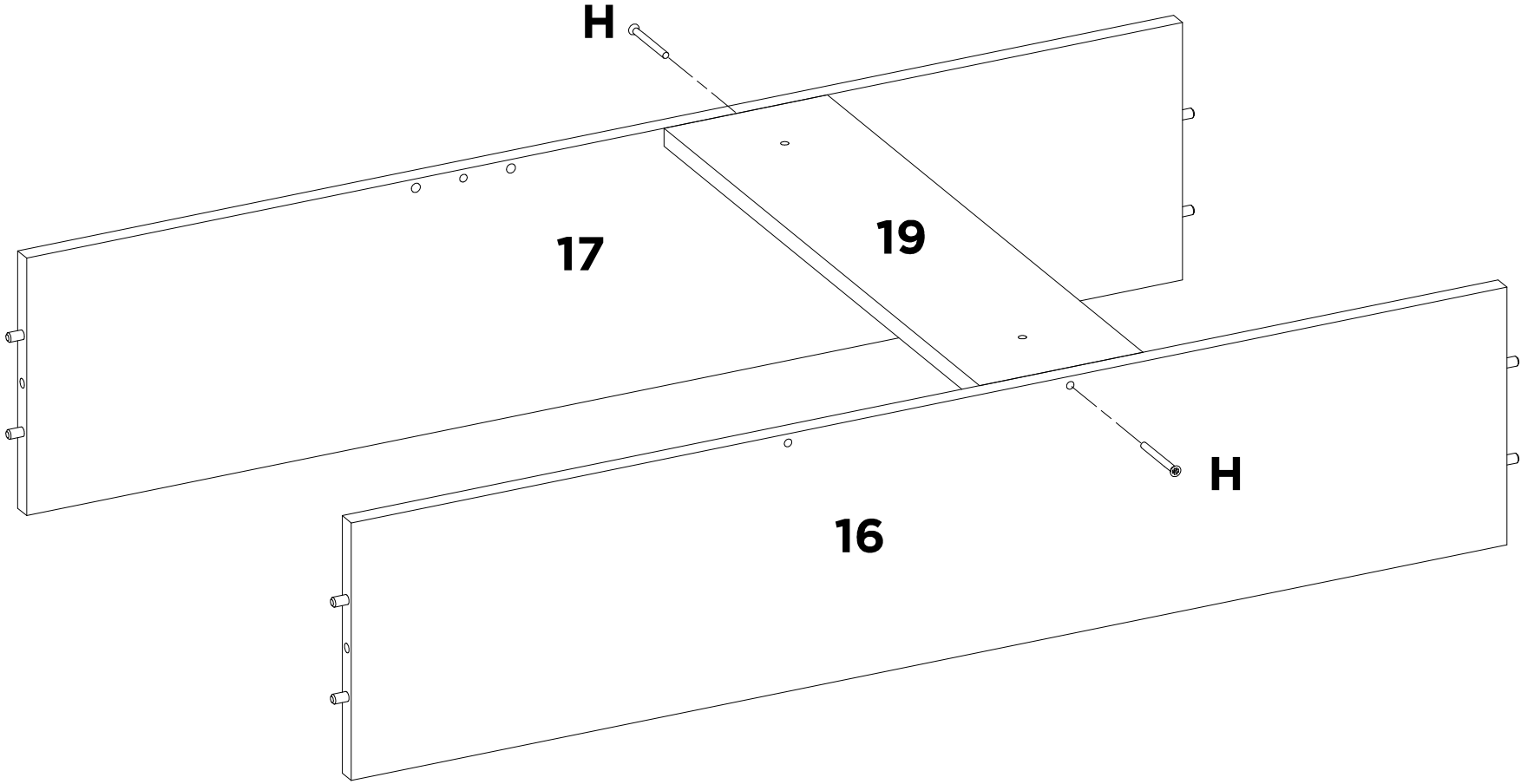

<b>H</b>	-	-	-	-	-	-	-
<b>X2</b>	-	-	-	-	-	-	-

# 03

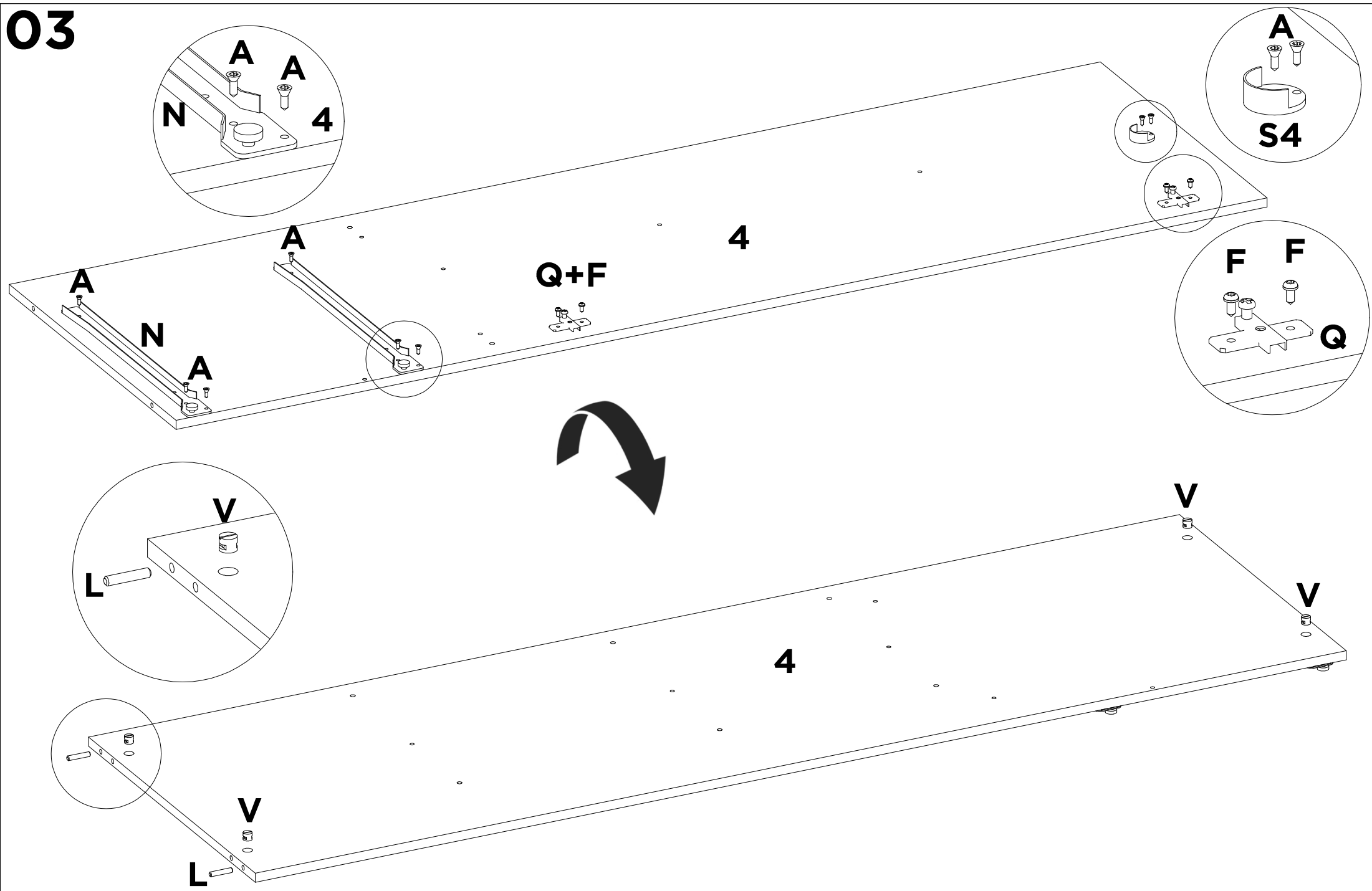

<b>N</b>	<b>A</b>	<b>Q</b>	<b>F</b>	<b>L</b>	<b>V</b>	<b>S4</b>	<b>-</b>
<b>X2</b>	<b>X8</b>	<b>X2</b>	<b>X4</b>	<b>X2</b>	<b>X4</b>	<b>X1</b>	<b>-</b>

**04**

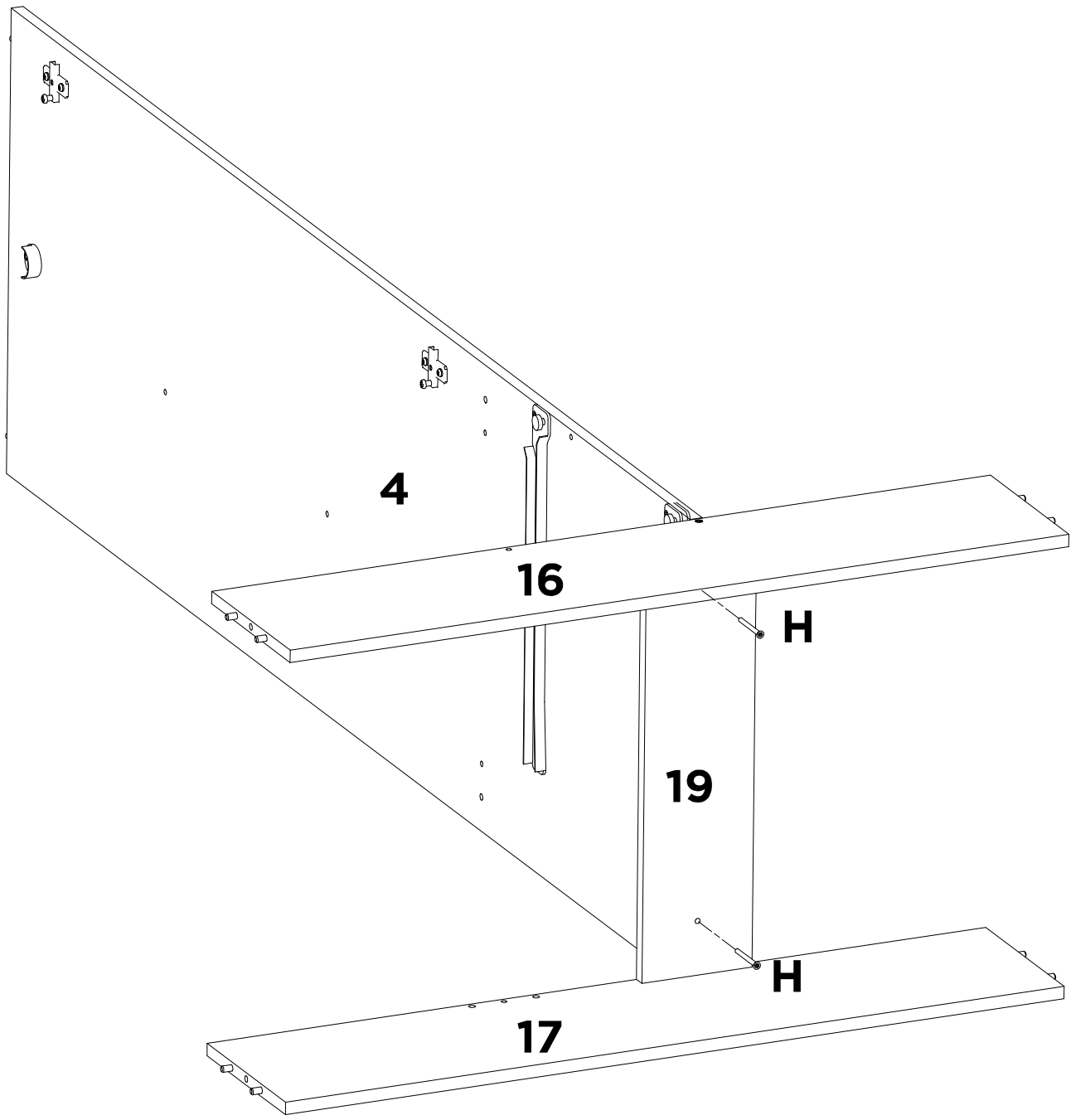

**H**  
**X2**

-  
-

-  
-

-  
-

-  
-

-  
-

-  
-

-  
-

**05**

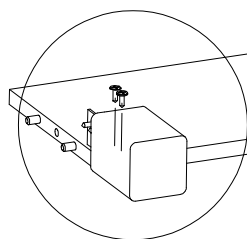
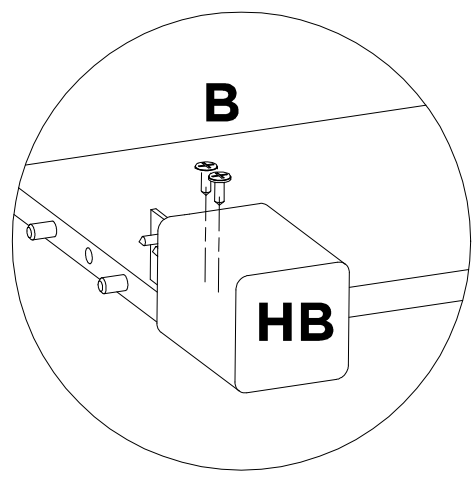
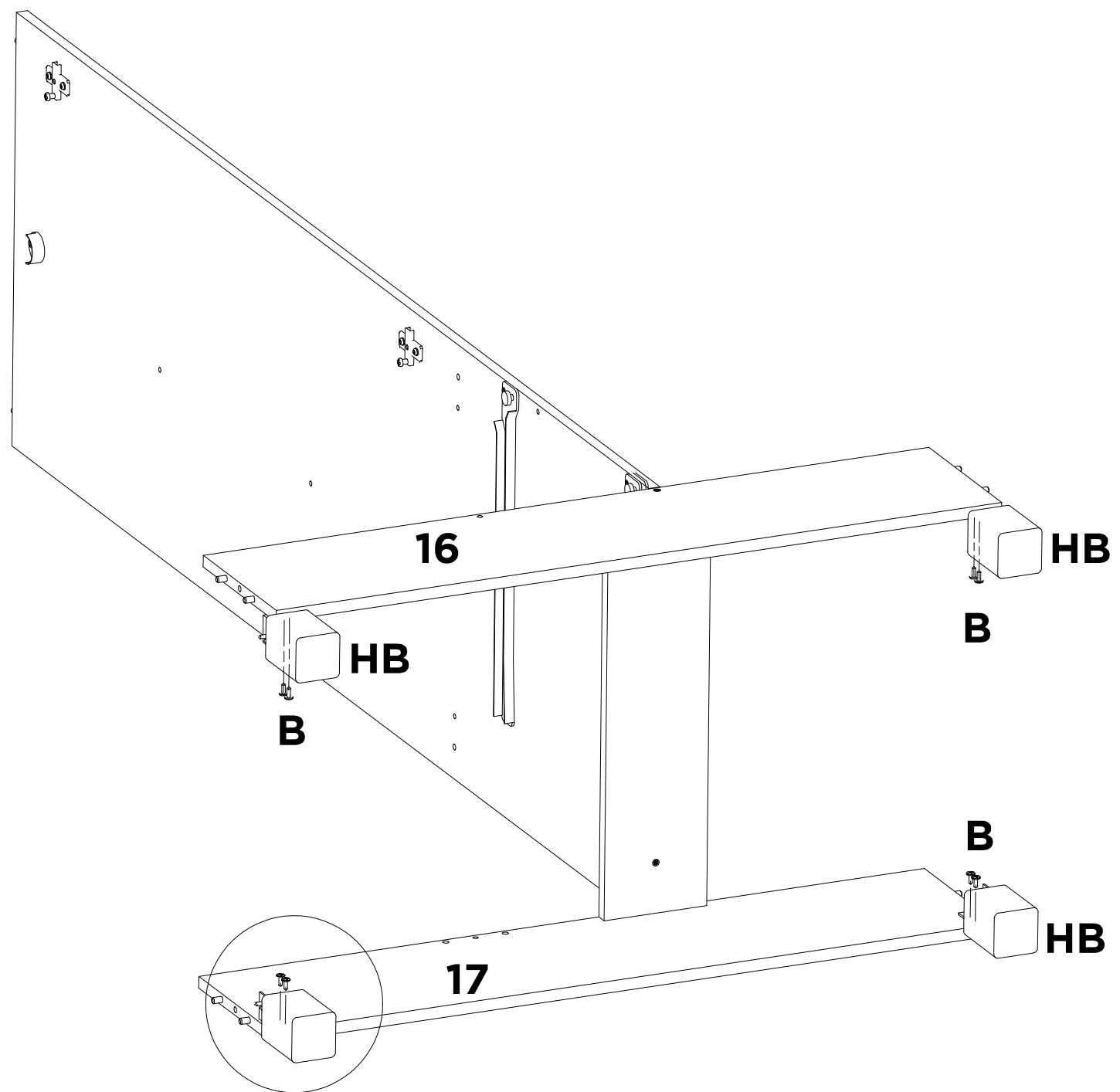

<b>HB</b> <b>X4</b>	<b>B</b> <b>X8</b>	-	-	-	-	-	-
------------------------	-----------------------	---	---	---	---	---	---

# 06

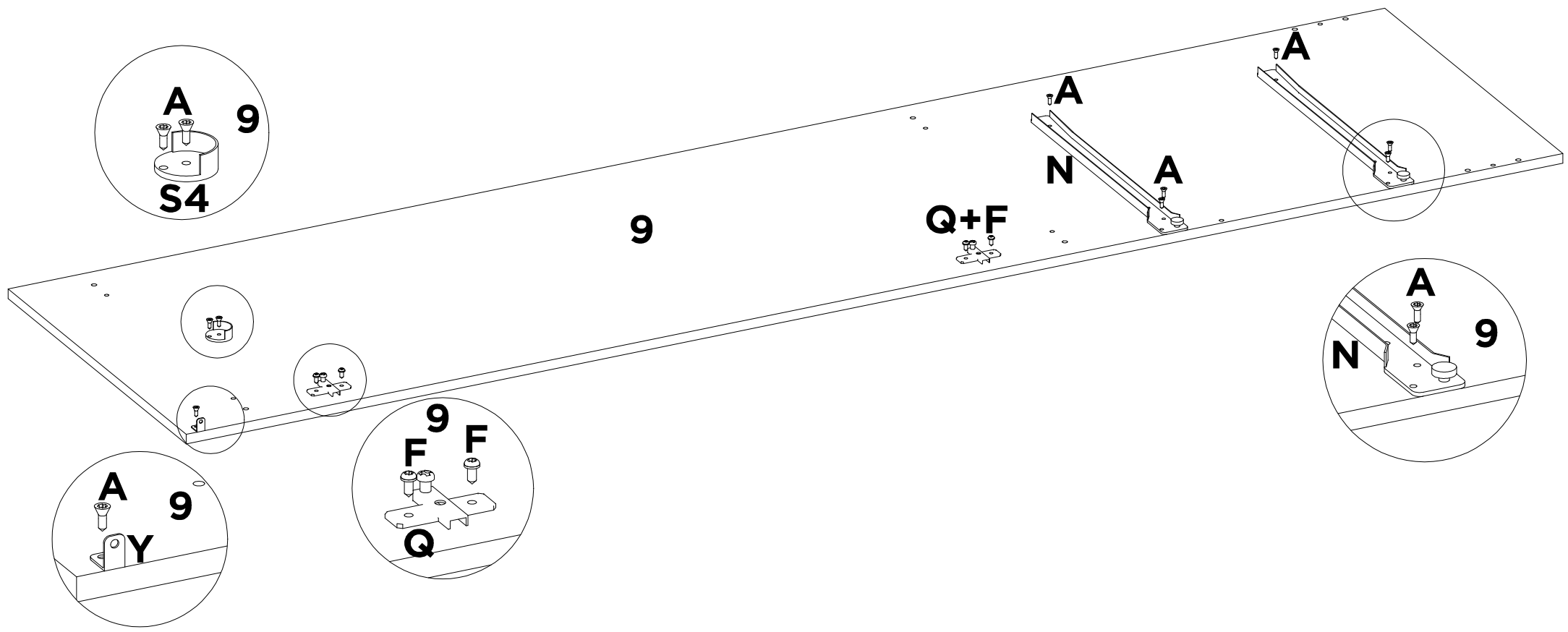

Y	A	S4	Q	F	N	-	-
X1	X9	X1	X2	X4	X2	-	-



**07**

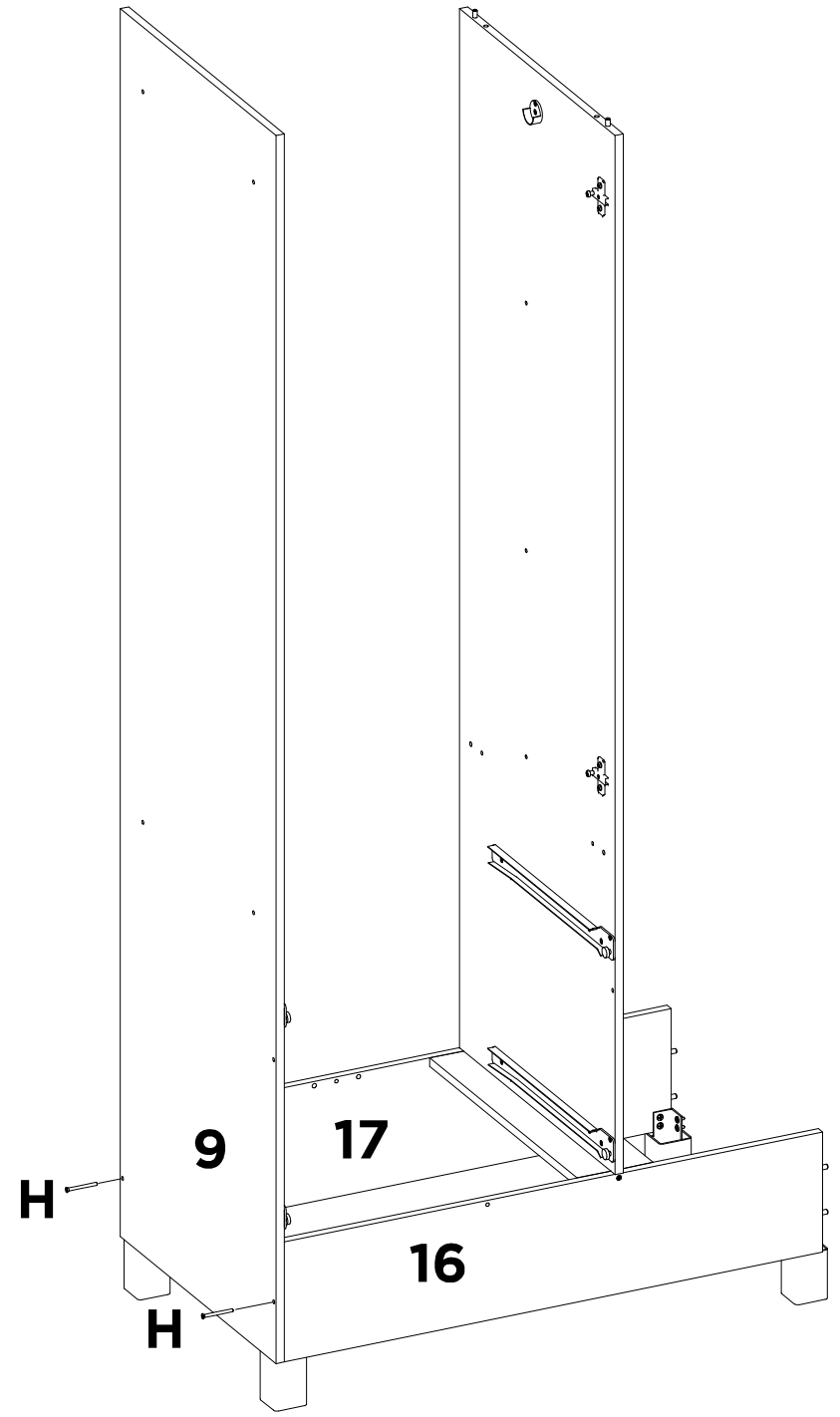

<b>H</b>	-	-	-	-	-	-	-
<b>X2</b>	-	-	-	-	-	-	-

# 08

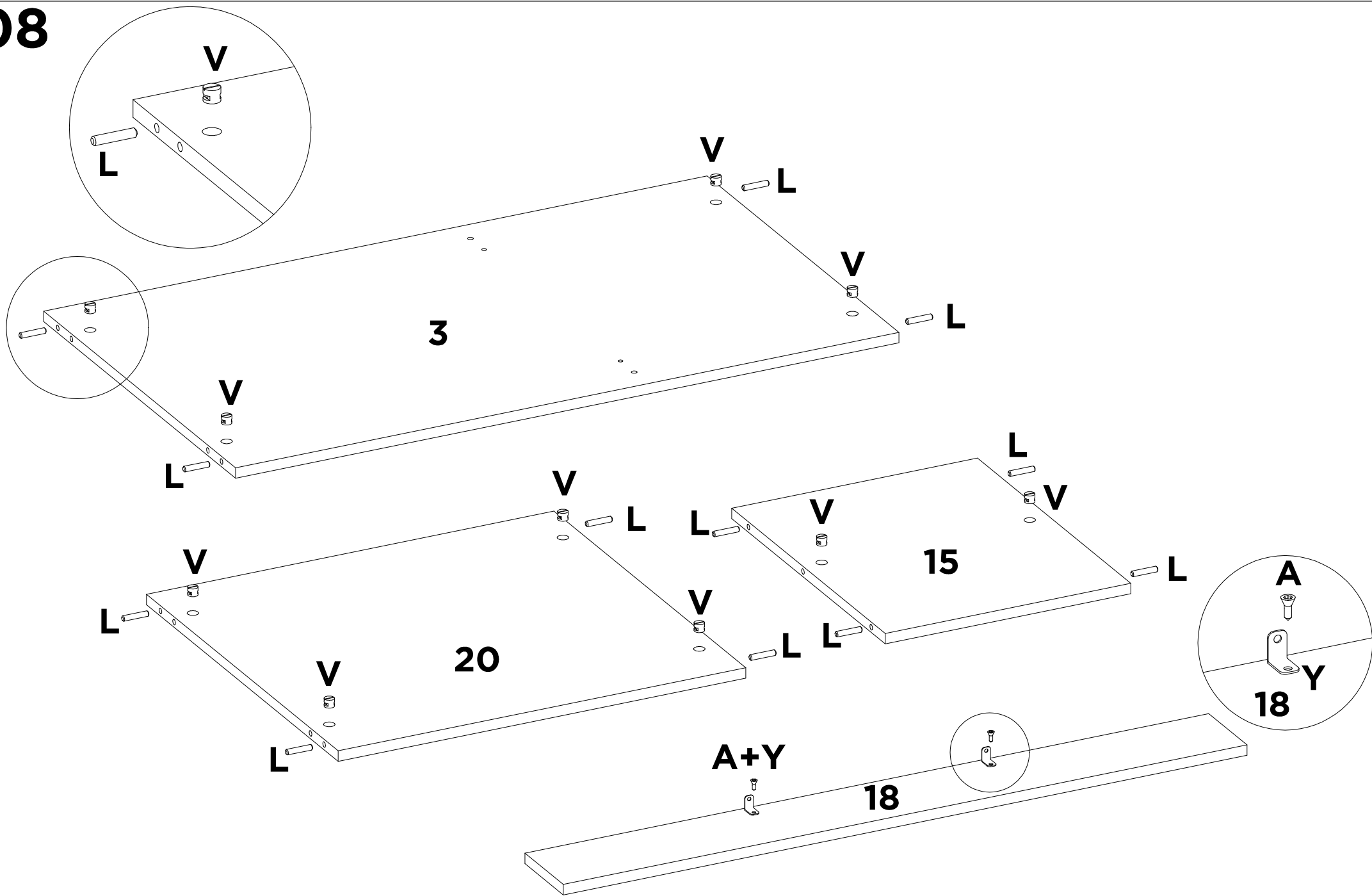

V	L	A	Y	-	-	-	-
X14	X20	X2	X2	-	-	-	-

**09**

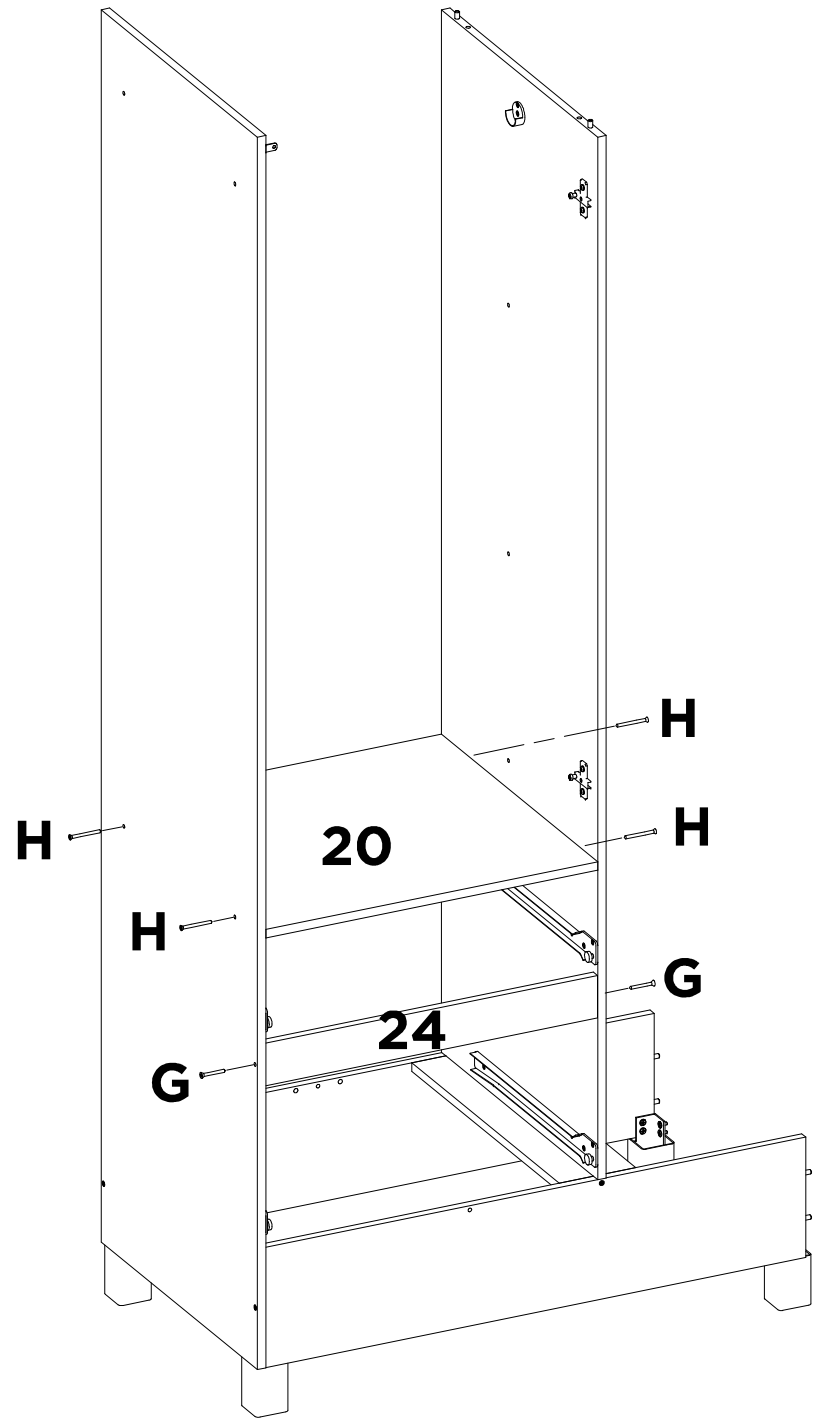

<b>H</b> <b>X4</b>	<b>G</b> <b>X2</b>	-	-	-	-	-	-
-----------------------	-----------------------	---	---	---	---	---	---

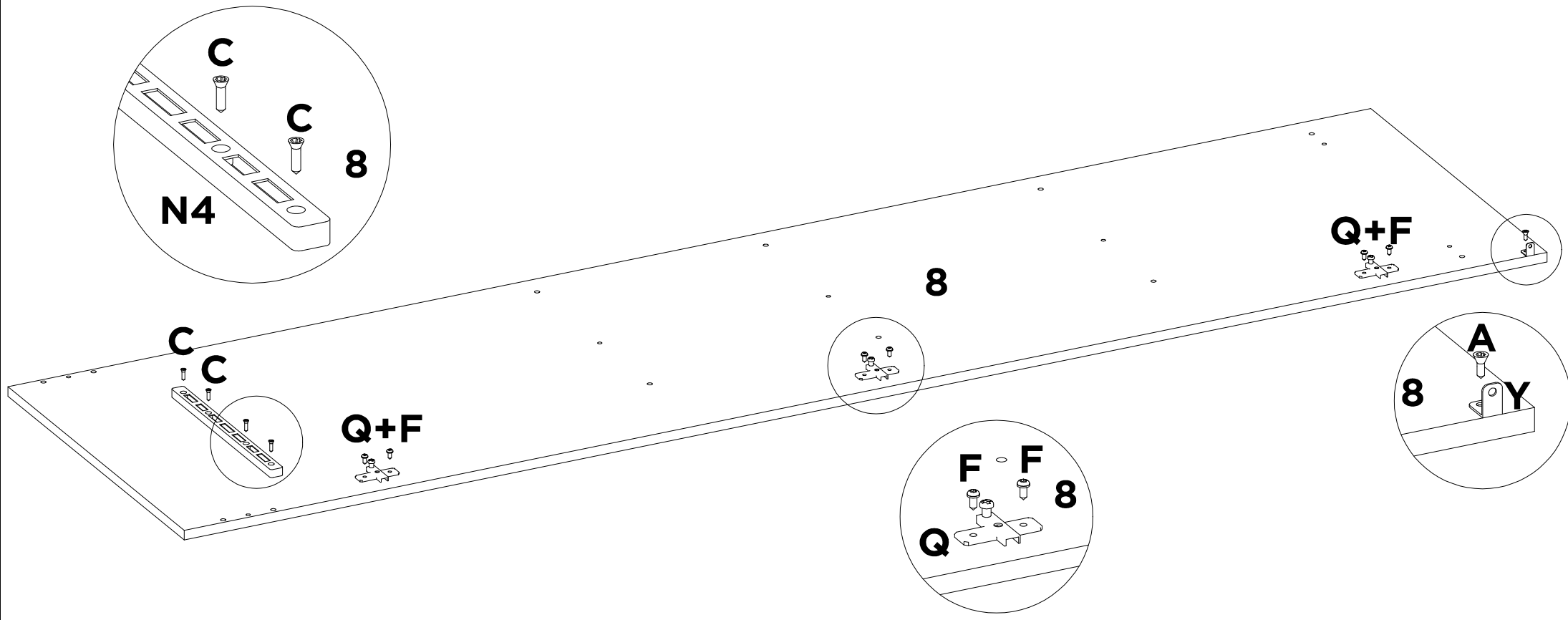

<b>N4</b> X1	<b>C</b> X4	<b>Q</b> X3	<b>F</b> X6	<b>Y</b> X1	<b>A</b> X1	-	-
-----------------	----------------	----------------	----------------	----------------	----------------	---	---

11

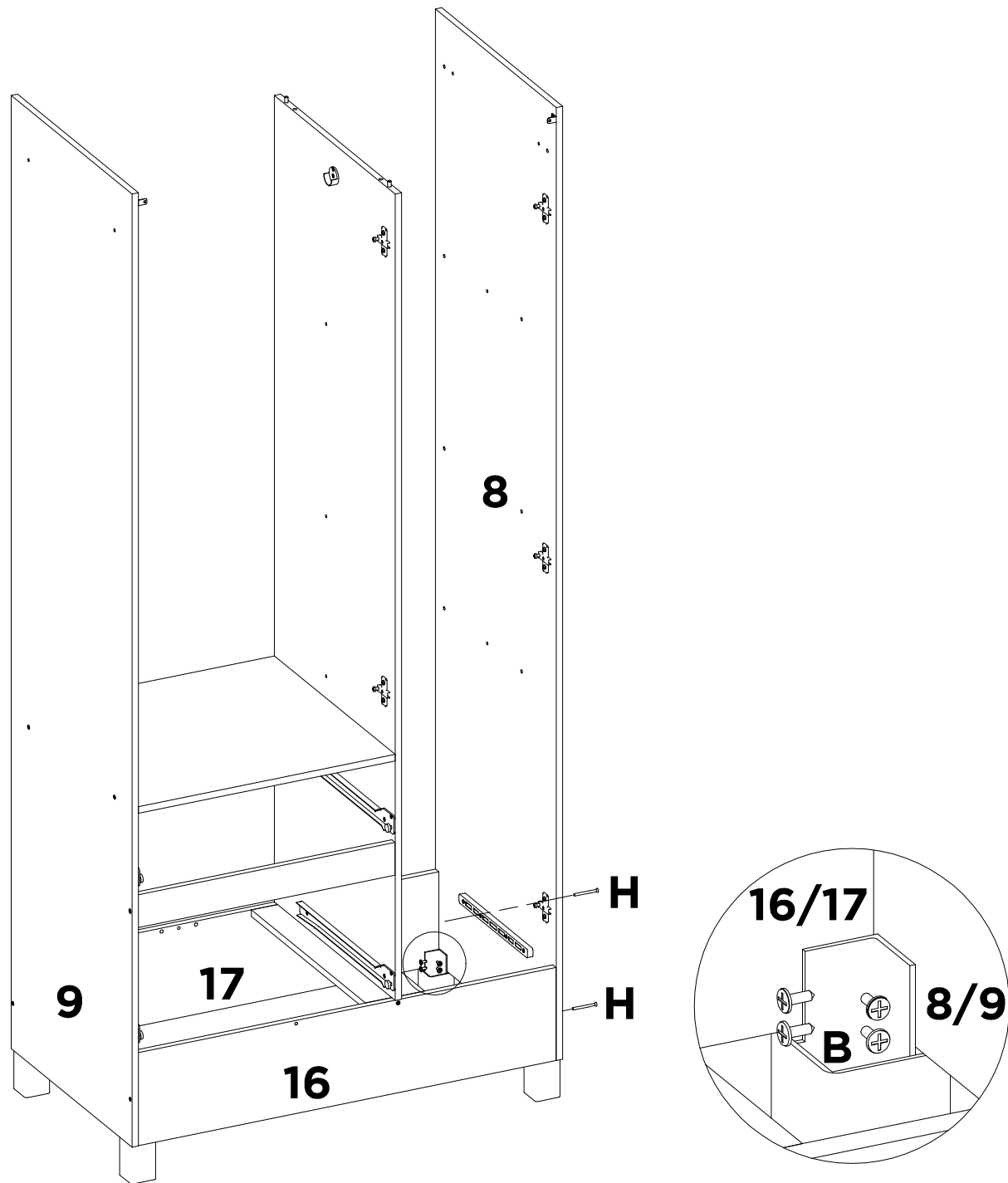

<b>B</b> <b>X8</b>	<b>H</b> <b>X2</b>	-	-	-	-	-	-
-----------------------	-----------------------	---	---	---	---	---	---

12

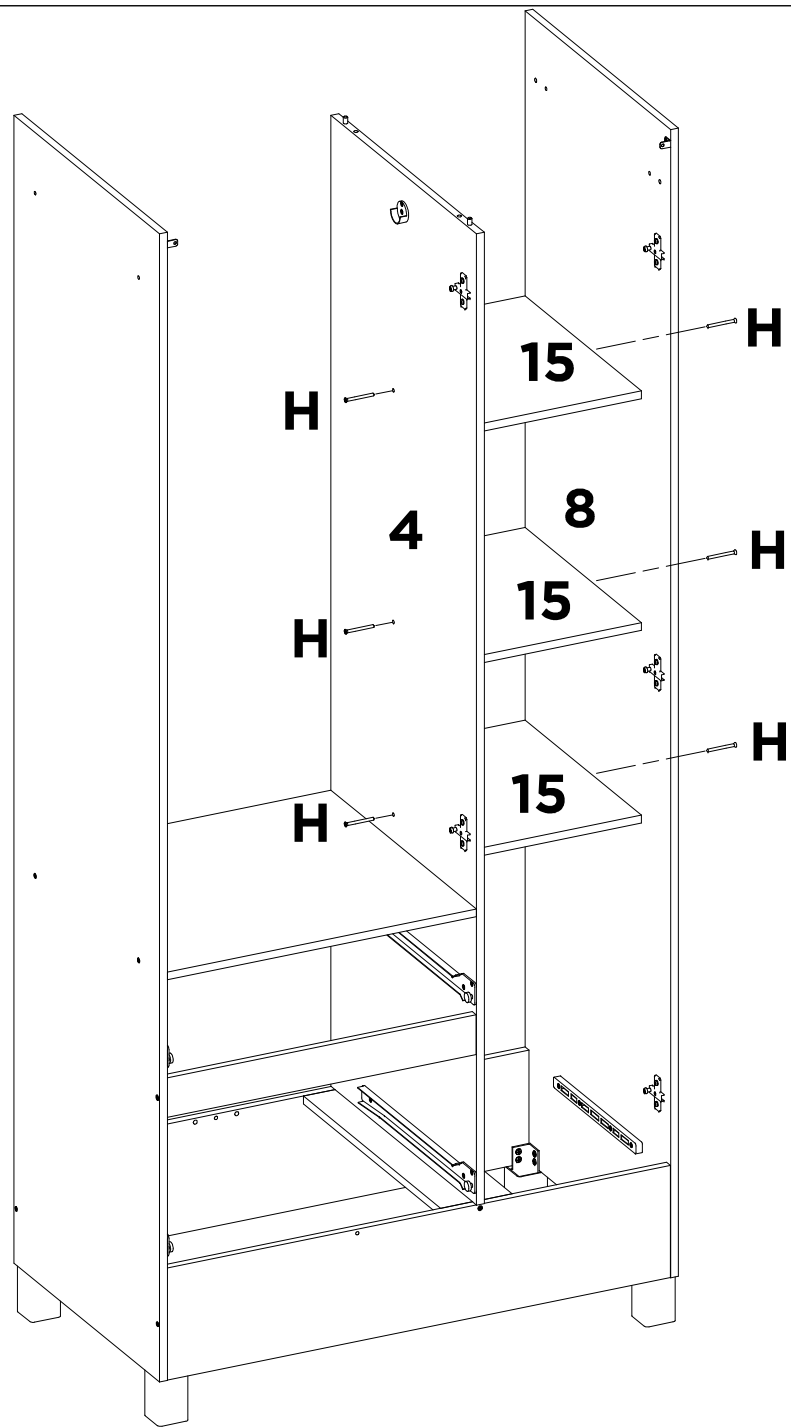

<b>H</b>	-	-	-	-	-	-	-
<b>X6</b>	-	-	-	-	-	-	-

13

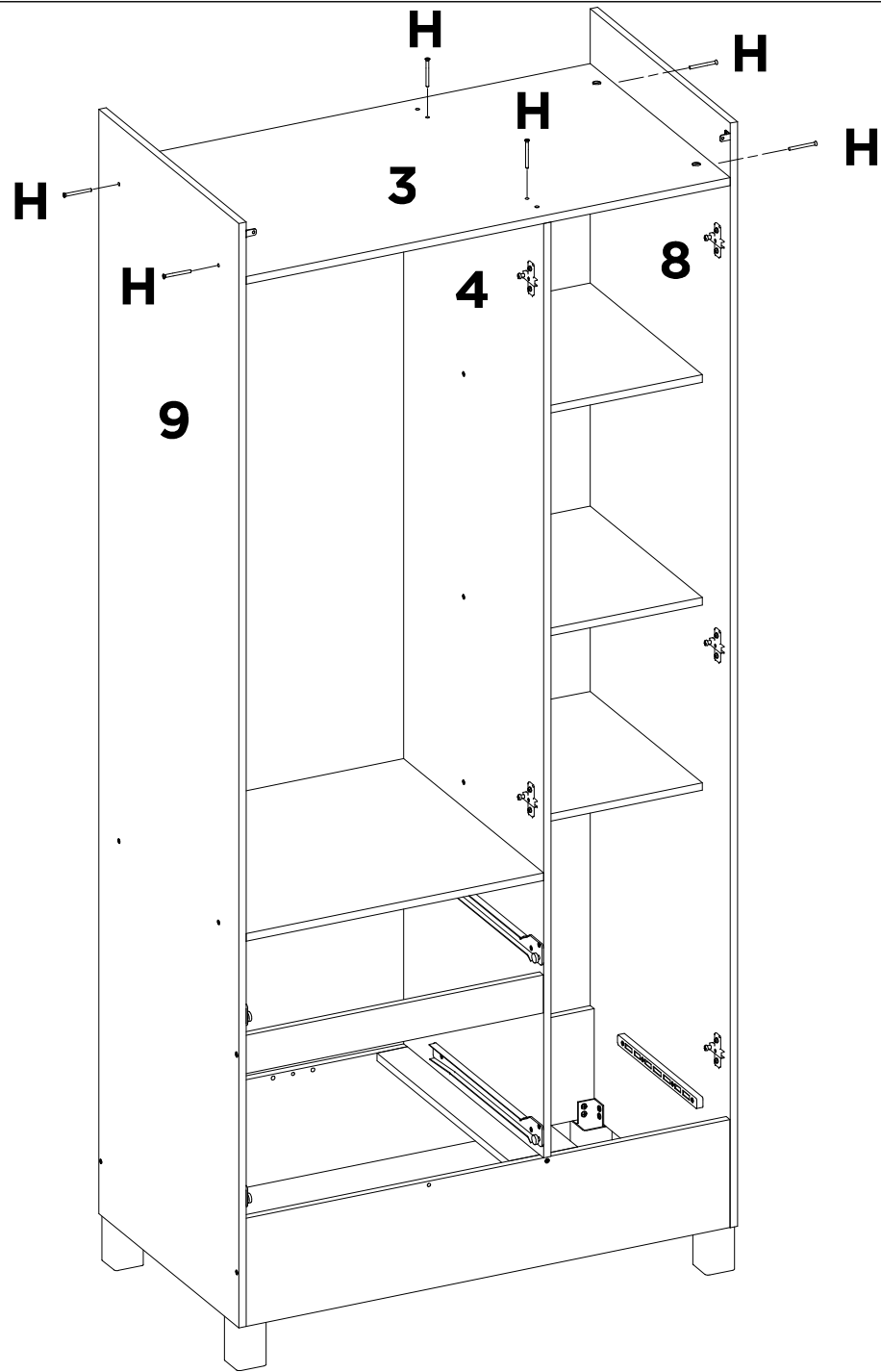

H	-	-	-	-	-	-	-
X6	-	-	-	-	-	-	-





15

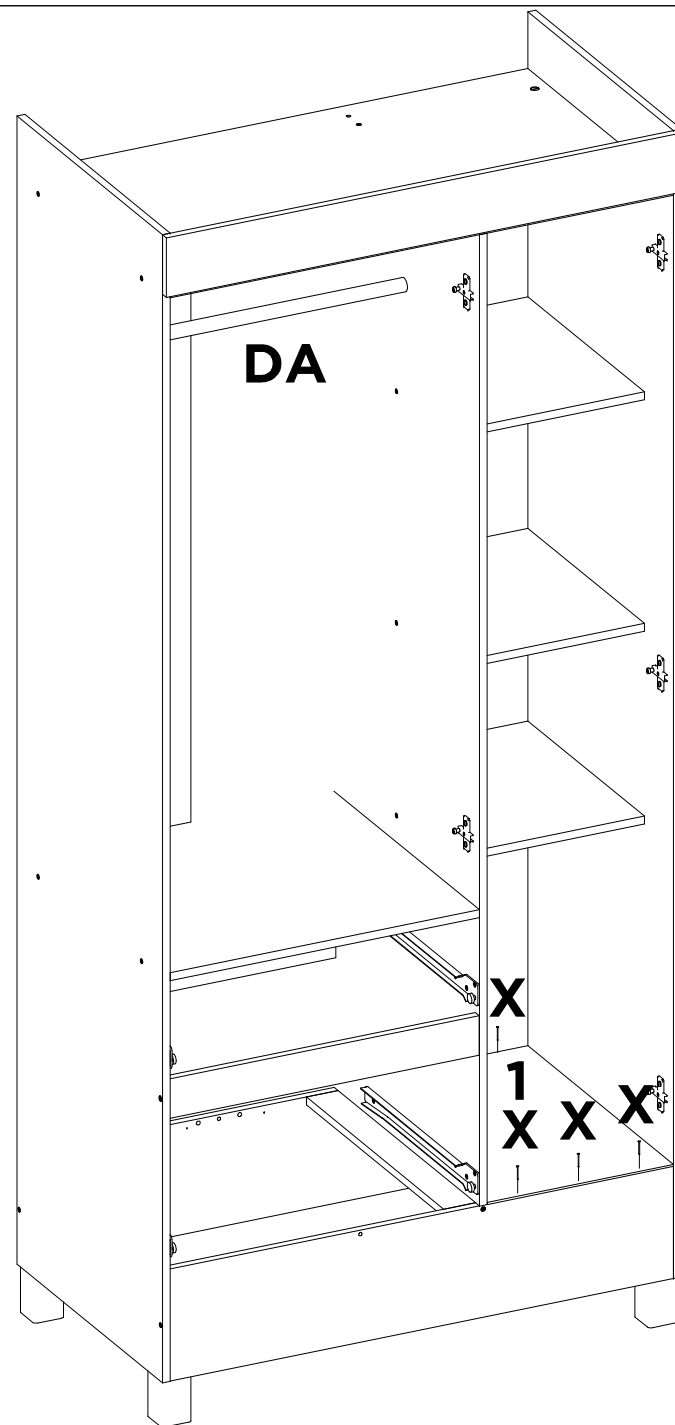

X X6	DA X1	NA X8	- -	- -	- -	- -	- -
---------	----------	----------	--------	--------	--------	--------	--------

# 16

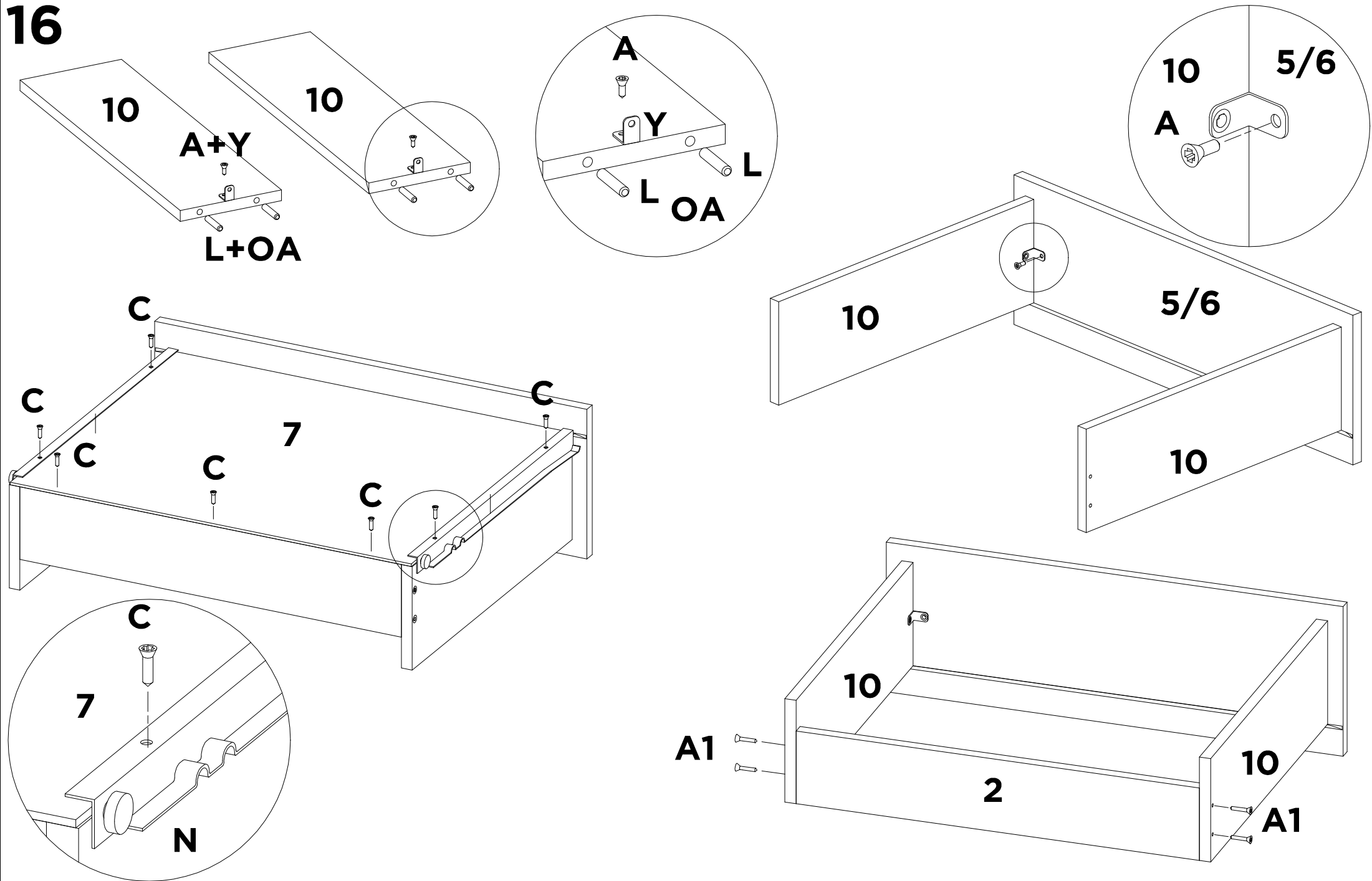

<b>L</b>	<b>A</b>	<b>OA</b>	<b>A1</b>	<b>N</b>	<b>C</b>	<b>Y</b>	<b>-</b>
<b>X8</b>	<b>X8</b>	<b>X1</b>	<b>X8</b>	<b>X2</b>	<b>X14</b>	<b>X4</b>	<b>-</b>

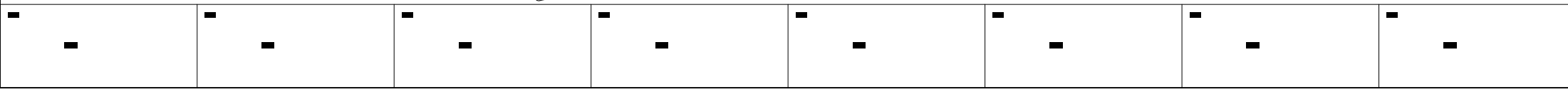
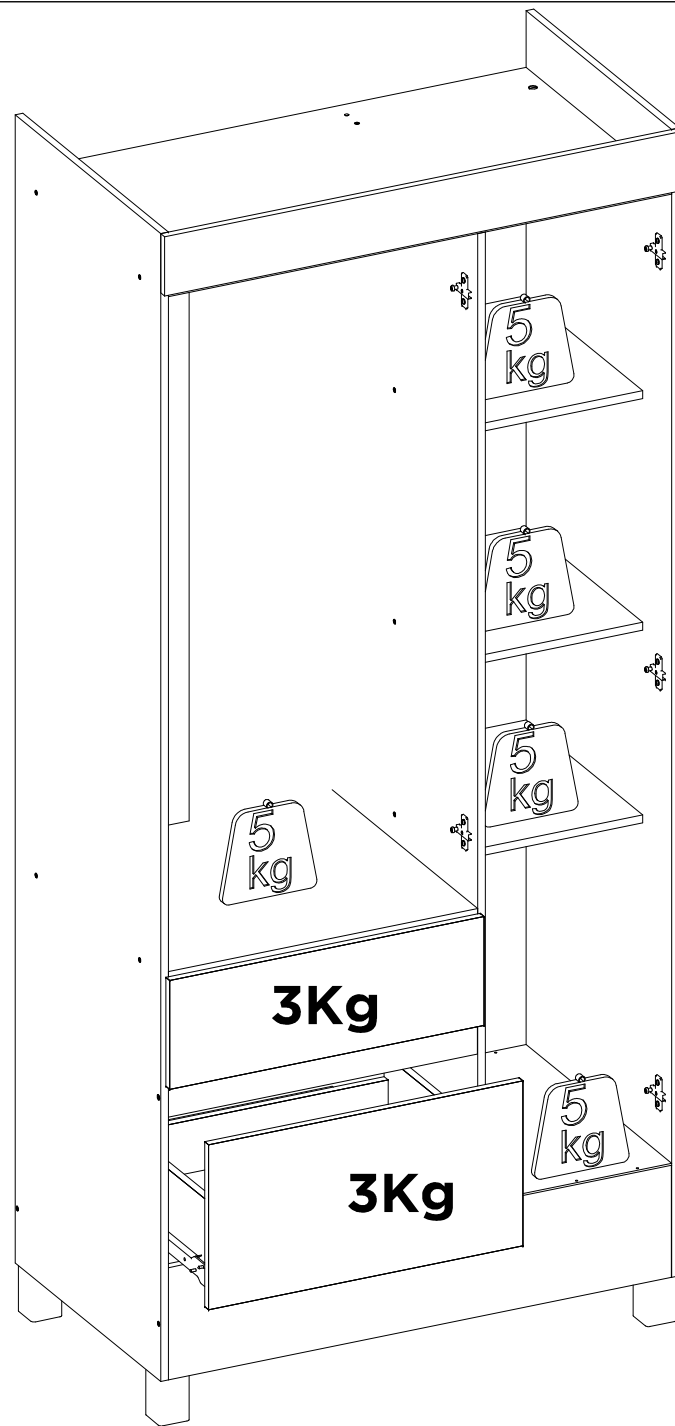

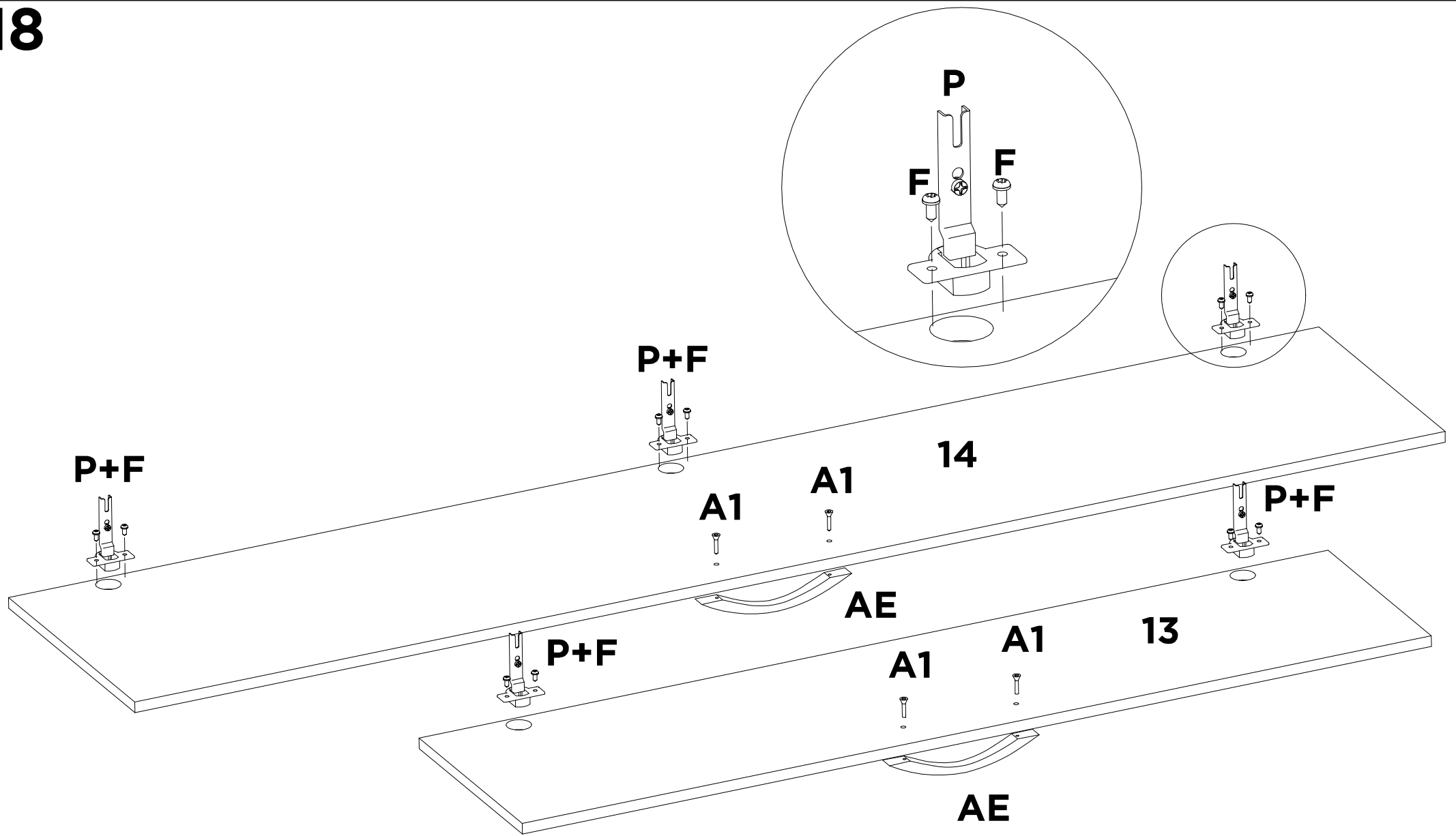

<b>P</b>	<b>F</b>	-	<b>A1</b>	<b>AE</b>	-	-	-
<b>X7</b>	<b>X14</b>	-	<b>X6</b>	<b>X3</b>	-	-	-

19

